

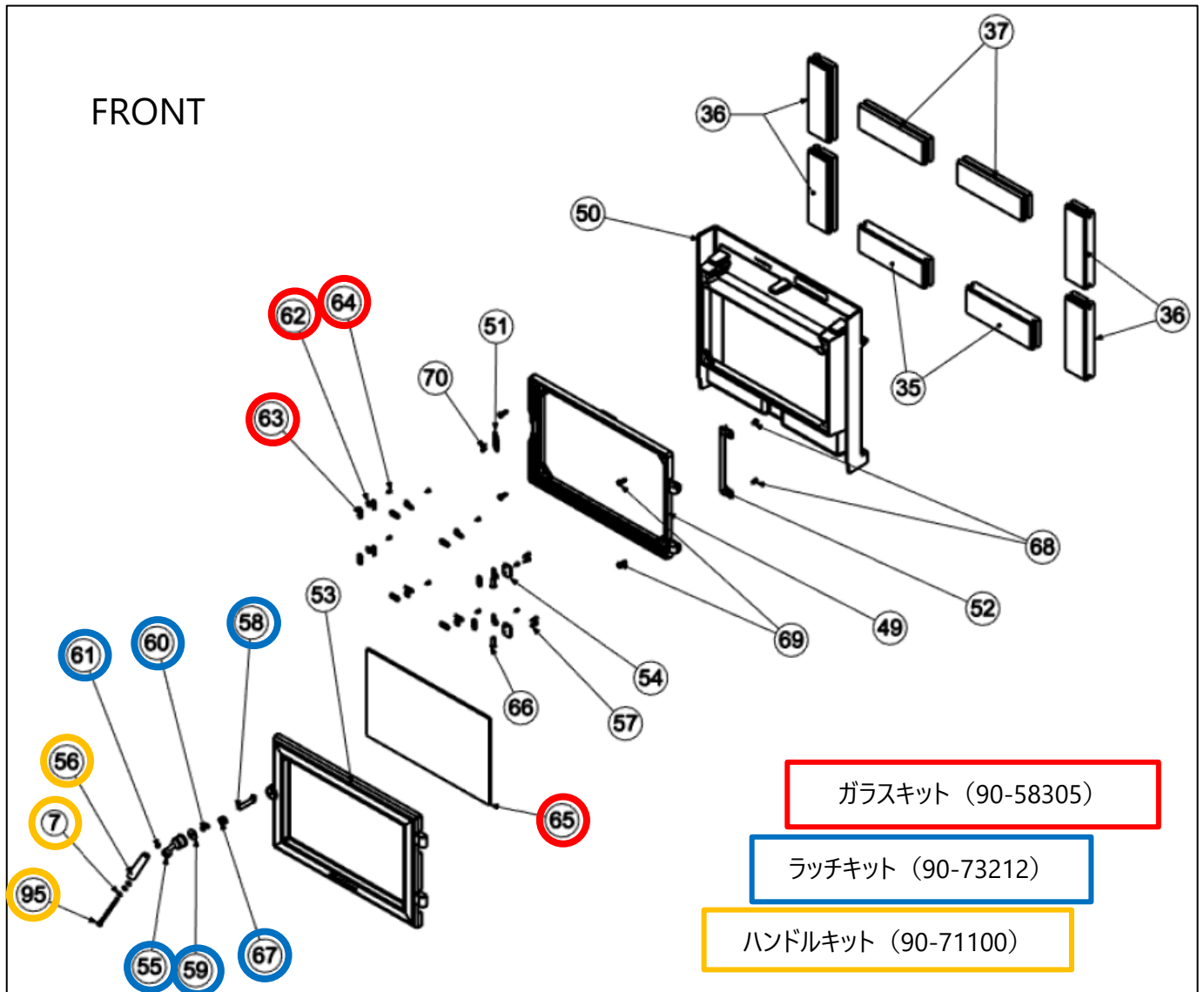

Castleton Model 8031 ハイブリッド

TruHybrid™

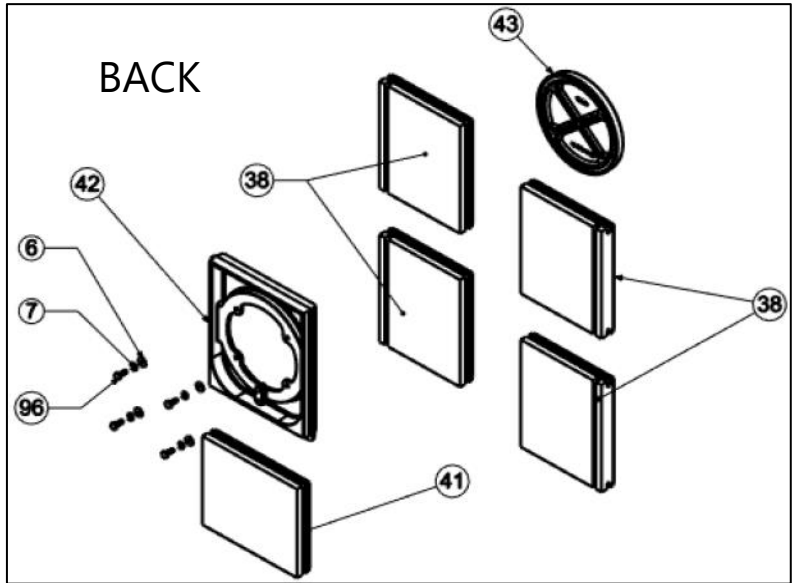

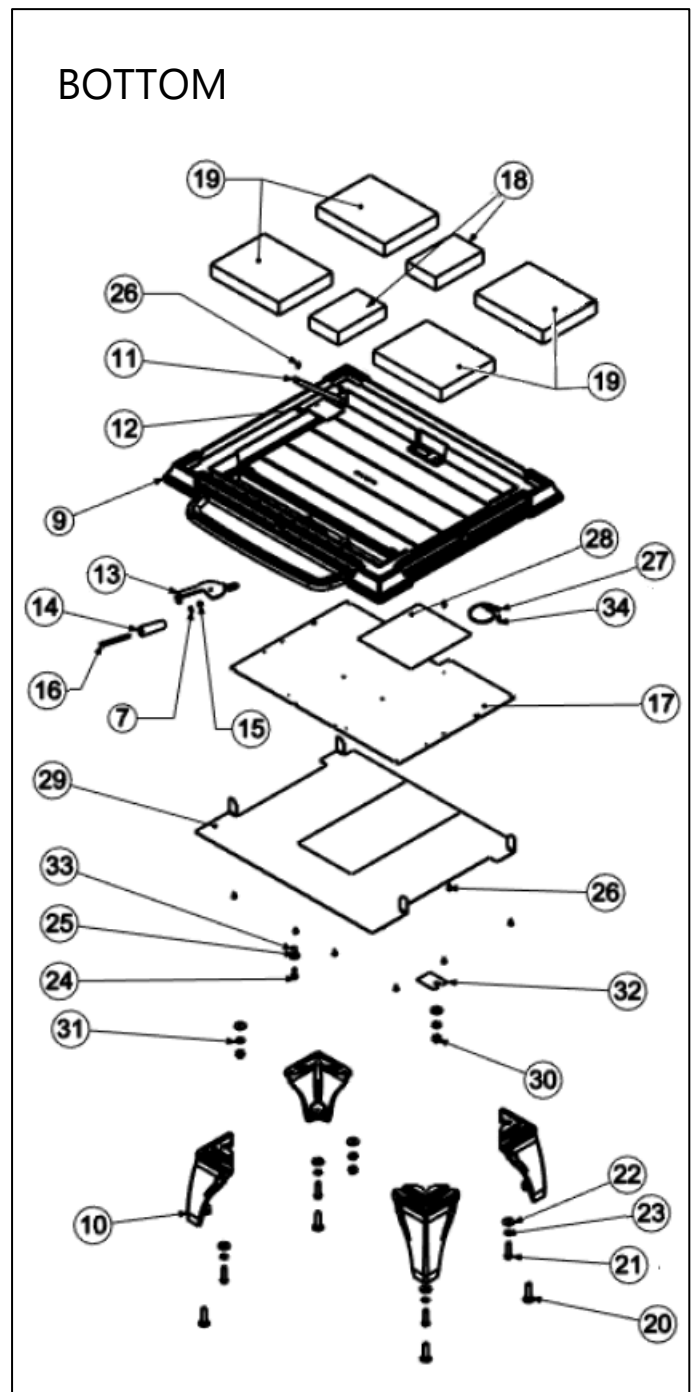
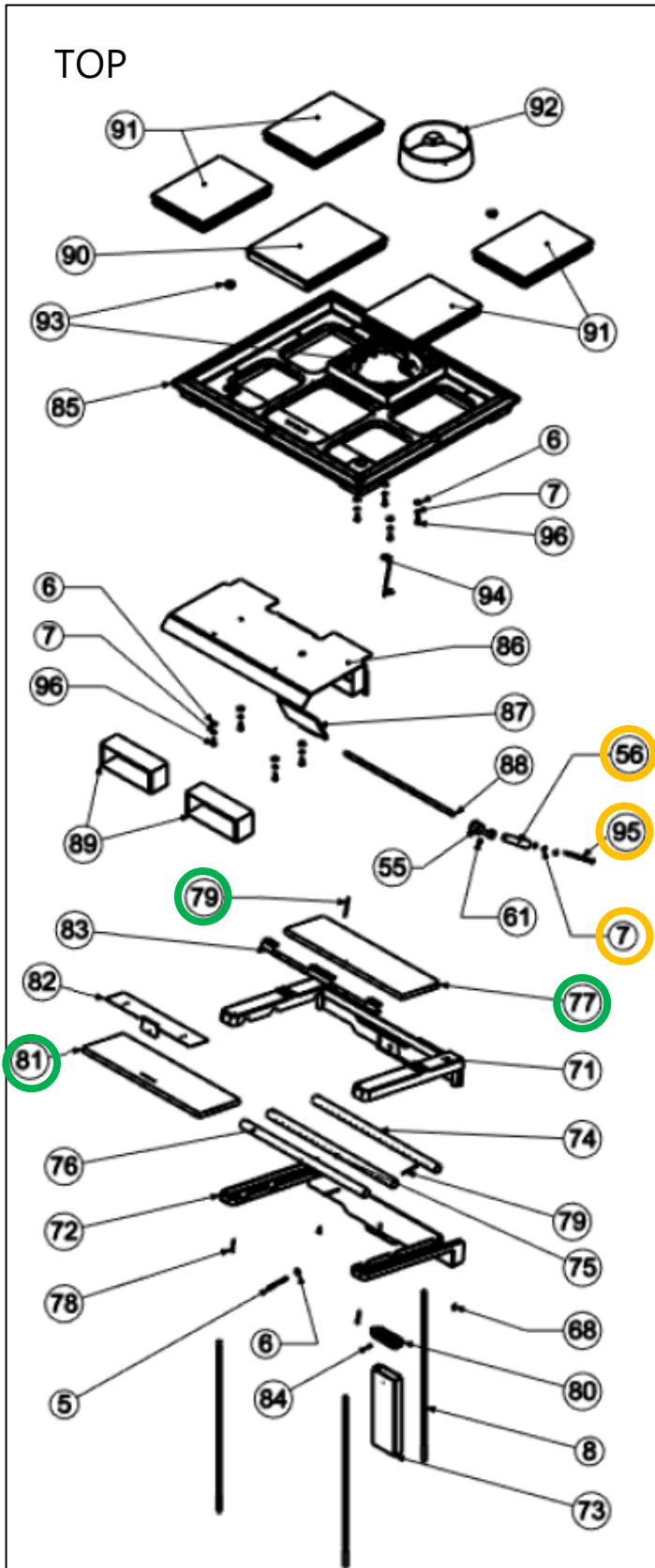

ハンドルキット (90-71100)

バッフルキット (90-76310)

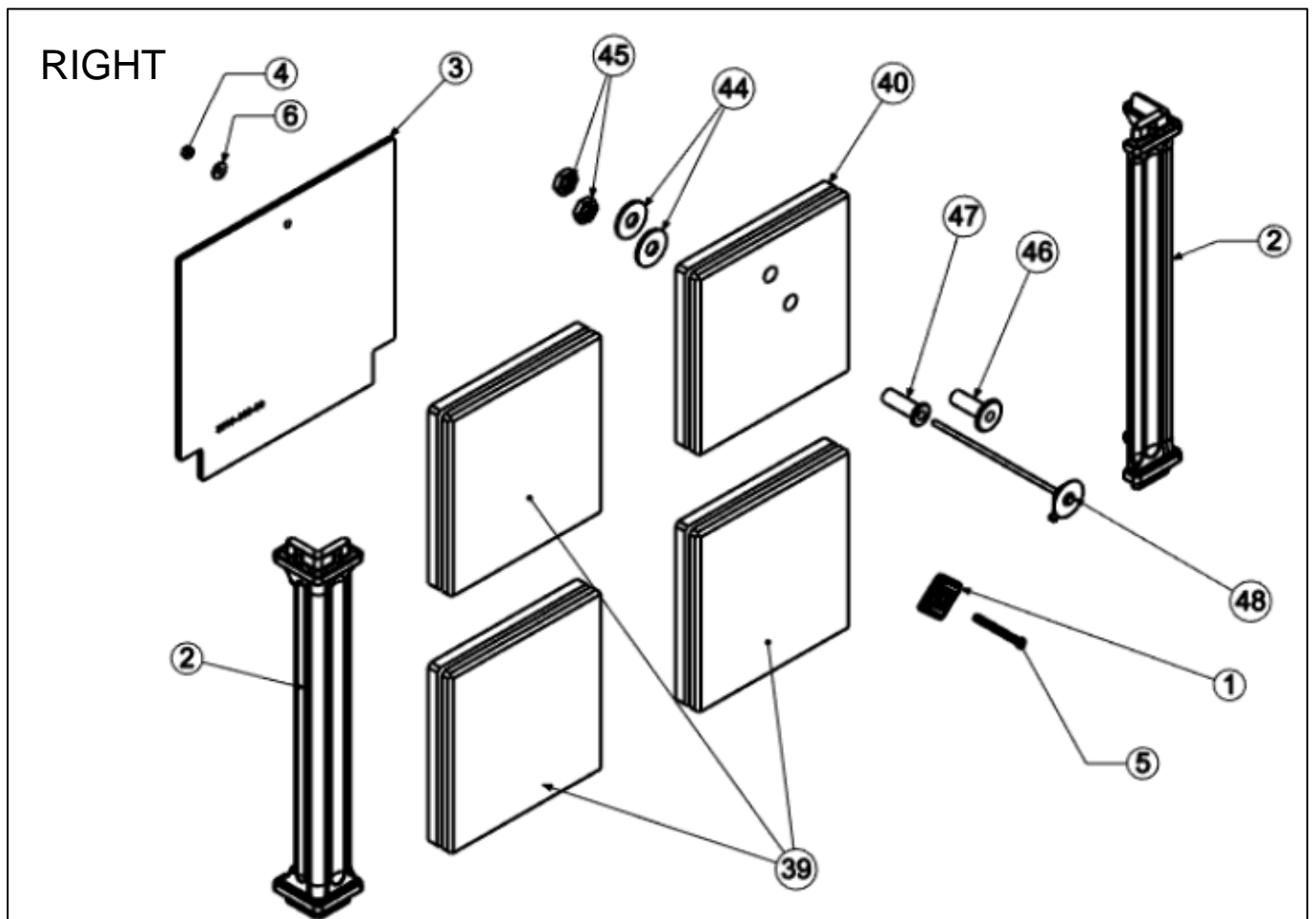
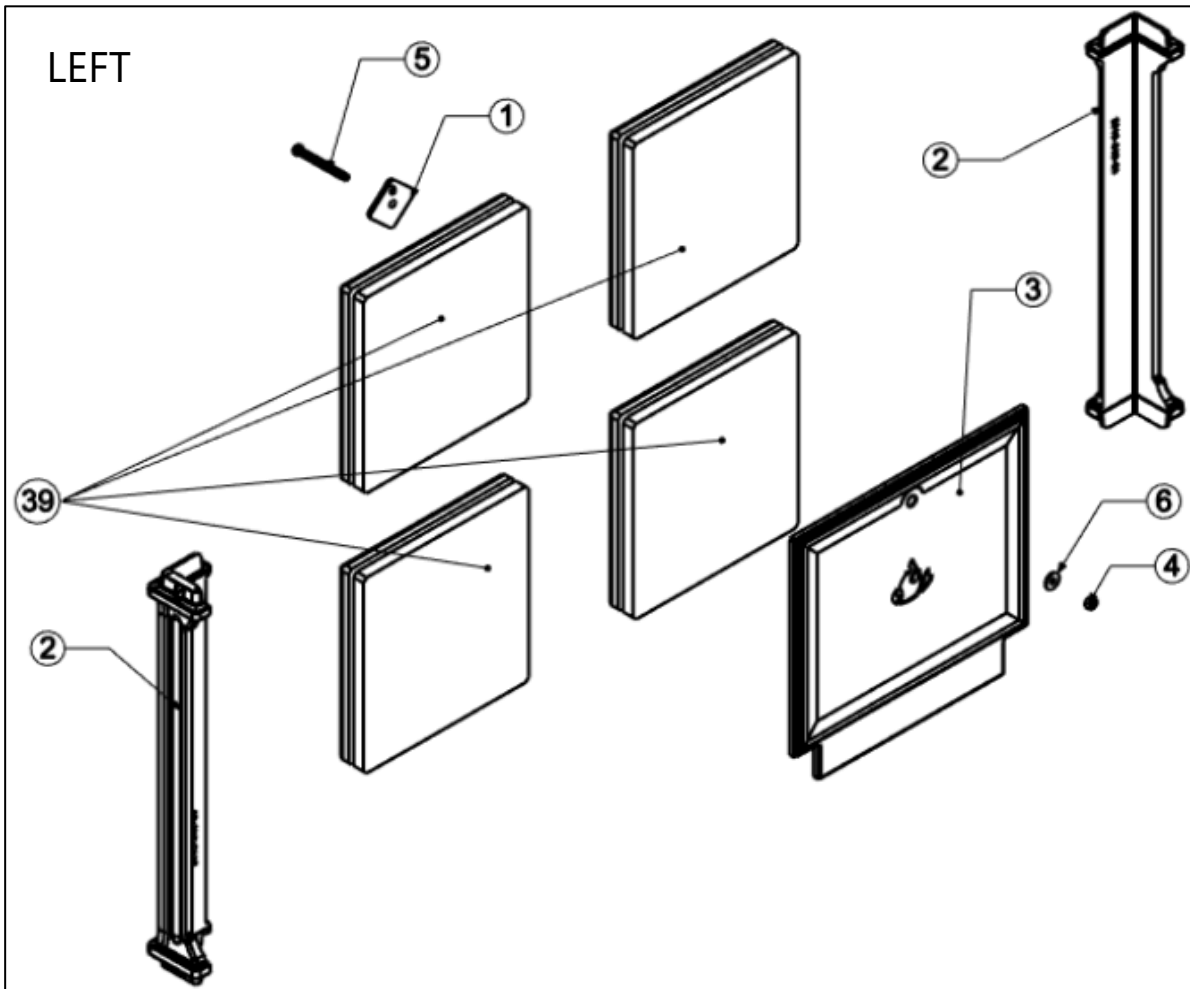

## 主要パーツ

Key	Part No.	Description	QTY.	定価 (税別)
	3110-057	ガスケット：フロントドア用	3/8"Low (9.5)	150cm 1100/m
	3110-056	ガスケット：ガラス用	1/4"(6.4)	140cm 900/m
	3120-021	ガスケット：ガラスクリップ用	セクション	8 400/ヶ
<b>90-58305 ガラスキット：キャスルトン8030/8031</b>				<b>38,800</b>
* ガラスキットには、ガラス用ガスケット、ガラスクリップ、ビス、ガラスクリップ用ガスケットが含まれます。				
65	3030-055	GLASS: IR 15.35"x9.49"x5MM,CAS	1	
62	5021-060	CLIP: GLASS,HER 1/TRI	8	1500/ヶ
63	3120-021	GASKET: GLASS CLIP, BLACK	8	400/ヶ
64	4500-2105	SCREW: MACH,10-24x3/8",UND-CUT,FLAT,PH	8	400/ヶ
	3110-056	GASKET: ROPE,1/4",BLK,AD	140cm	900/m
<b>90-76310 バッフルキット：キャスルトン8031</b>				<b>23,800</b>
81	3120-031	BOARD: CERAMIC,FRONT,CAS 1	フロントバッフル	1 10,700
77	3120-032	Ceramic Baffle Rear, CAS8031	リアバッフル	1 10,700
79	4300-0120	PIN: COTTER,1/8x2",SS	割りピン	3 800/ヶ
<b>90-71100 木製ハンドルキット：フロントドアMAN/PHX/HER/CAS/TRI</b>				<b>4,500</b>
* フロントドアハンドルとバイパスドアハンドルは共通です。				
56	3900-177	HANDLE: WOOD,BLACK	1	4,100
95	4500-1680	SCREW: MACH,1/4-20x3-1/4",ROUND,SLOT,Z	1	1,600
7	4600-0400	WASHER: LOCK,1/4,SPLIT,MED,ZN	2	400/ヶ
<b>90-73212 ラッチキット：フロントドアHER8021/TRI/CAS</b>				<b>13,800</b>
55	5010-081	CRANK: HANDLE,WOOD STOVES	1	5,200
58	5021-022	LATCH:DR,FRT,SINGLE BEV,HER1/TRI(Deinsa)	1	6,600
59	5021-032	WASHER: FLAT,.406"IDx1"ODx.035"T,BLK	1	600
60	4700-0790	SPACER: DOOR LATCH,0.435"x0.375"x0.03"	4	400
61	4500-2976	SCREW: SET,5/16-18x3/8",HALF DOG,SOCKE	1	800
67	5240-138	SPRING: LATCH,WOOD STOVES,325#	1	2,500
<b>90-58313 コンバスターガスケットキット：CAS1/HER4/MCR2</b>				<b>4,500</b>
	3120-035	Ceramic Blanket Strips	セラミックブランケット	2
<b>90-75310 コンバスター交換キット：CAS1/HER4/MCR2</b>				<b>66,000</b>
89	3050-010	CATALYST, 6"	2	
	3120-035	Ceramic Blanket Strips		

Key	Part No.	Description	定価 (税別)	
1	2010-335	TRIM:SIDE,MATTE,CAS/TRI	6,200	
2	2010-340	LEG:SIDE,MATTE,CAS	26,100	
3	2010-345	PLATE:SIDE,CAS	49,000	
4	4200-0250	NUT: FINISHING,1/4-20,HEX,SS	600	
5	4500-1420	SCREW: SHCS,LOW,1/4-20X2 1/4",BL OX	2,000	
6	4600-0310	WASHER: FLAT,1/4,SAE,ZN (5/8" OD)	400	
7	4600-0400	WASHER: LOCK,1/4,SPLIT,MED,ZN	400	
8	5210-2340	ROD:THREAD,3/8-16x19-1/2", 5/16"&2",cas	2,600	
9	2010-320	BOTTOM:MATTE/CAS	144,200	
10	2010-310	FOOT:MATTE,HER 1,2,3/CAS	26,100	
11	5021-020	RETAINER: SLIDE,PRI AIR CONTROL,HER1/TRI	6,000	
12	5021-025	SLIDE: PRIMARY AIR CONTROL,HER 1/TRI	3,100	
13	5031-032	AIR CONTROL HANDLE		
14	3900-182	HANDLE: WOOD,ASH PAN,HER 1, PHX, MANS	4,500	
15	4200-0200	NUT: FINISHING,1/4-20,HEX,ZN	400	
16	4500-1574	SCREW: MACH,1/4-20x2-1/2",ROUND,PH,ZN		
17	5030-010	HEATSHIELD:BOTTOM,CAS	7,800	
18	1-0000-315	STONE: REF,3.27"x5.35",CAS	5,500	
19	1-0000-102	STONE: REF,6"x7-5/8",MAN 1	9,800	
20	4100-0127	BOLT: CARRIAGE,3/8-16x1-1/2 BL OX	1,000	
21	4500-3220	SCREW: CAP,5/16-18x1-1/4",HEX,ZN,GR5	600	
22	4600-0800	WASHER: FLAT,5/16,USS (7/8" OD),BLK ZN	400	
23	4600-0850	WASHER: LOCK,5/16,SPLIT,MED,ZN	400	
24	4100-0280	SCREW: SHOULDER,5/16"Dx1/4"L,SOCKET	800	
25	5570-060	WASHER: SLIDE ARM,SHE/HOM	1,600	
26	4500-2114	SCREW: MACH,10-24x3/8",PAN,PH,BLK OX	400	
27	5570-030	CABLE: LABEL,1/16"Dx12",2 EYES		
28	3300-721	BLOWER LABEL		
29	5031-010	HEATSHIELD: SUPPLEMENT, BOTTOM,CAS 1	14,800	
30	4200-0400	NUT: FINISHING,3/8-16,HEX,ZN	600	
31	4600-0700	WASHER: LOCK,3/8,SPLIT,MED	400	
32	5031-041	SECONDARY REDUCTION PLATE		
33	4600-1400	WASHER:WAVE,5/16,0.030" HEIGHT(90134A0	1,400	
34	4400-0100	RIVET: BLIND,1/8x1/4" GRIP,SS (CCP-4	600	
35	1141-330	STONE: POL,8.23" x 2.87",FB,CAS	9,700	
36	1141-340	STONE: POL,2.56" x 8.05",FS,CAS	8,200	
37	1141-350	STONE: POL,2.52" x8.23",FT,CAS	8,200	
38	1141-310	STONE: POL,RS,6-13/16"x8-1/16",CAS	19,200	
39	1141-320	STONE: POL,7.78" x 8.05",S,CAS	22,100	
40	1141-321	STONE,SIDE,R,T,B POLISHED		
41	1141-325	STONE: POL,6.66" x 8.00",RC,CAS	18,500	
42	2010-281	REAR EXIT PLATE		
43	2010-282	PLATE: FLUE, HER/MCR/CAS	16,500	
44	4600-0880	WASHER:WROUGHT,9/16"x1-1/2"(90108A034	1,000	
45	4200-0100	NUT: 9/16"-18	2,400	
46	5031-125	BYPASS ESCUTCHEON	5,100	
47	5031-130	PROBE ESCUTCHEON	5,100	
48	7200-525	THERMOMETER: CATALYST, 7", CAS1	11,000	
49	2010-360	FRAME:DOOR,MATTE,CAS	39,400	
50	2010-330	PLENUM:AIR,PRIMARY,CAS	68,800	
51	5030-060	STRIKER:LATCH,CAS,HER2-L	フロントドアストライカー	5,300
52	5030-050	SUPPORT:HINGE PIN,CAS	11,700	
53	2010-350	DOOR:MATTE,CAS	42,400	
54	5030-055	PLATE:HINGE,CAS	5,100	
* 55	5010-081	→ 90-73212 : ラッチキット		
* 56	3900-177	→ 90-71100 : ハンドルキット		

Key	Part No.	Description	定価 (税別)
57	4500-2132	SCREW: SHCS,10-24x1/2",BL OX	600
* 58	5021-022	→ 90-73212 : ラッチキット	
* 59	5021-032	→ 90-73212 : ラッチキット	
* 60	4700-0790	→ 90-73212 : ラッチキット	
* 61	4500-2976	→ 90-73212 : ラッチキット	
* 62	5021-060	→ 90-58305 : ガラスキット	
* 63	3120-021	→ 90-58305 : ガラスキット	
* 64	4500-2105	→ 90-58305 : ガラスキット	
* 65	3030-055	→ 90-58305 : ガラスキット	
66	5030-045	BUSHING:HINGE,CAS	3,100
* 67	5240-138	→ 90-73212 : ラッチキット	
68	4500-0560	SCREW: MACH,1/4-20x1/2",FLAT,PH,BLK OX	400
69	4500-1359	SCREW: MACH,1/4-20x3/4",PAN,PH,BLK	1,000
70	4500-2106	SCREW: MACH,10-24x3/8",FLAT,PH,BL OX	400
71	2010-380	PLENUM: AIR,SECONDARY,TOP,CAS	49,000
72	2010-370	PLENUM: AIR,SECONDARY,BOTTOM,CAS	42,400
73	5030-040	RISER:SECONDARY,AIR,CAS	8,000
74	5030-071	TUBE:SECONDARY,AIR,#1,CAS	17,600
75	5031-072	TUBE:SECONDARY,AIR, #2,CAS1	17,600
76	5031-073	TUBE:SECONDARY,AIR, #3,CAS1	17,600
* 77	3120-032	→ 90-76310 : バッフルキット	
78	4500-1300	SCREW: MACH,1/4-20x1-1/4",FLAT,PH,BLK	600
* 79	4300-0120	→ 90-76310 : バッフルキット	
80	5023-048	GASKET KEEPER	
* 81	3120-031	→ 90-76310 : バッフルキット	
82	5022-014	BRACKET: BAFFLE,SS,HER2	9,900
83	5031-105	REAR BAFF SUPPORT	
84	4500-3435	SCREW: T-CUT,8-32x3/8","F",PAN,PH,BL	400
85	2010-390	TOP:MATTE,CAS	130,900
86	5031-110	CATALYST DAM	
87	5031-115	BYPASS DOOR	
88	5031-120	BYPASS SHAFT	
* 89	3050-010	→ 90-75310 : コンバスターキット	
90	1141-360	STONE: POL,7.99" x 10.47",TC,CAS	30,000
91	1141-370	STONE: POL,6.81" x 9.00",TS,CAS	22,300
92	2010-285	COLLAR: FLUE,MATTE,HER/TRI/MCR/CAS	26,100
93	4200-0410	NUT: TAMPER-RESISTANT,3/8-16,ZN	1,600
94	5021-070	BRUSH STOPPER:WD STVS,HER TYPE COLLAR	4,500
* 95	4500-1680	→ 90-71100 : ハンドルキット	
96	4500-0701	SCREW: CAP,1/4-20x5/8",HEX,SS	

\* 主要パーツのキット内訳をご参照ください。

※ 鋳鉄パーツのエナメルカラーは別途お問合せください。(ブラウンエナメル : 20、シーフォーム : 61)

オプション

※オプションの詳細は各技術資料をご参照ください。

90-53300	外気導入キット : キャスルトン8030/8031		
5903-005	BOX: OUTSIDE AIR,CAS	1	
4500-3436	SCREW: T-CUT,10-24x3/8,"F",PAN,PH,BLK	4	400
90-68300	リアヒートシールド : キャスルトン8030/8031		
5903-015	HEATSHIELD: REAR,CAS	1	
5904-015	BRACKET: REAR HEATSHIELD,TRI	2	
5903-010	HEATSHIELD: REAR, BLANK,CAS	1	
5902-120	HEATSHIELD: REAR EXTENSION,HER 1/CRA	1	
4500-3435	SCREW: T-CUT,8-32x3/8","F",PAN,PH,BL	4	400
4500-3436	SCREW: T-CUT,10-24x3/8,"F",PAN,PH,BLK	6	400
4500-0540	SCREW: MACH,1/4-20x3/8",PAN,PH,BL OX	4	600