



TEST REPORT

TEST OF A HYBRID WOOD STOVE FOR EMISSIONS AND EFFICIENCY

PER EPA METHODS 28R AND ASTM E2515 and ASTM E2780, MAY 2015

Client:

Hearthstone QHHP
317 Stafford ave.
Morrisville, Vt 05661

Model name: Manchester 8362

Attention: Rafaël Sanchez

TESTED BY:

Services Polytests Inc.
695-B Gaudette
St-jean-sur-Richelieu, QC, J3B 7S7

TEST DATES: July 30th to August 3rd 2018

REPORT DATE: August 8th 2018

Project number: PI-20174

All services undertaken are subject to the following general policy: Reports are submitted for exclusive use of the clients to whom they are addressed. Their significance is subject to the adequacy and representative character of the samples and to the comprehensiveness of the tests, examinations or surveys made. This document may not be reproduced except in its entirety without the written permission from Services Polytests. Services Polytests have not been involved in any R&D design consulting regarding this unit as requested by the NSPS..

Tested:

written by:

Maxime Martin

Danick Power, P. Eng

Verified by third party certifier (DIRIGO Lab):

SUMMARY

1	Introduction	5
1.1	General.....	5
1.2	Test unit information	5
1.3	Results.....	5
1.4	Pretest information.....	6
2	Summary of test results.....	6
2.1	Emissions.....	6
2.2	Average calculation.....	7
2.3	Test facility conditions	7
2.4	Fuel qualities	8
2.5	Dilution tunnel flow rate measurements and sampling data (ASTM E2515).....	8
2.6	Dilution tunnel dual train precision	9
2.7	General summary of results.....	9
3	Process description.....	10
3.1	Discussion	10
3.2	Unit dimensions	10
3.3	Air supply system	11
3.4	operation during test	12
3.5	Start-up operation	12
3.6	Sampling locations	12
3.7	Drawings	13
3.8	Emissions efficiency testing equipment list	13
4	Sampling methods	13
4.1	Particulate sampling	13
5	Quality assurance	13
5.1	Instrument calibration	13
5.1.1	Gas meters.....	13
5.1.2	SCALES	13
5.1.3	Gas analyzers	13
5.2	Test method procedures.....	14
5.2.1	Leak check procedures	14
5.2.2	Tunnel velocity flow measurement	14

5.2.3 Pm sampling proportionality (ASTM E2515) 14

List of appendix

- APPENDIX 1: Raw data, forms and results
- APPENDIX 2: Proportionality results
- APPENDIX 3: Calibration data
- APPENDIX 4: Unit pre burn
- APPENDIX 5: Participants
- APPENDIX 6: Drawings and specifications
- APPENDIX 7: Operator's manual
- APPENDIX 8: Photographs of test set up
- APPENDIX 9: Test load photographs
- APPENDIX 10: Laboratory Operating Procedures
- APPENDIX 11: Sample calculations
- APPENDIX 12: Volume calculations
- APPENDIX 13: Operating instruction
- APPENDIX 14: Drawing Air flow pattern

1 INTRODUCTION

1.1 GENERAL

Laboratory

- Location: Services Polytests Inc., 695-B Gaudette St-jean-sur-Richelieu QC, Canada J3B 7S7
- Elevation: 100 feet above sea level

Test program

- Purpose: unit qualification NSPS 2020
- Test dates: July 30th to August 3rd 2018
- Test methods used:
 - Particulate emissions: ASTM E2780-10 ; ASTM E2515-11 methods 28R as referred into 40 CFR Part 60 Subpart AAA
 - Efficiency: CSA B415.1-10

1.2 TEST UNIT INFORMATION

General

- Manufacturer: Hearthstone
- Product type: Hybrid wood stove
- Combustion system: catalytic, with post combustion
- Unit tested: Manchester 8362
- Option: optional convection fan can be installed on the wood stove

1.3 RESULTS

Emission results obtained

- Average emission rate: 0.65 grams/hour
- Average Efficiency: 77.8 %

Conformity: NSPS Phase 2020

1.4 PRETEST INFORMATION

Unit condition: The unit was received by carrier first week of July 2018. The 50hrs of aging was done by the manufacturer (all data in Appendix 4).

Set up

- Venting system type: 6 inch diameter insulated chimney
- System height from floor: 15 feet
- Particularities: The unit was tested with the convection Fan ON for average numbers (Test #1,2,3 and 4), and one confirmation test is done without any convection fan (test #5).

Break in period

- Duration: the unit was pre burned by the manufacturer and run for at least 50 hours, adequate documentation of fuel additions, flue and unit temperatures recorded.
- Fuel: BC FIR between 19% and 25%

2 SUMMARY OF TEST RESULTS

2.1 EMISSIONS

Run Number	Test Date (AAA-MM-DD)	Emission Rate (g/hr)	Burn Rate (kg/hr)	1st hour Emission Rate (g/hr)	CSA B415.1 CO emission Gr/hr	CSA B415.1 CO emission Gr/Kg dry
1	2018-07-30	0,49	1,07	2,37	40,46	37,99
2	2018-07-31	0,32	0,95	1,45	37,04	39,18
3	2018-08-01	0,76	1,55	1,68	63,46	40,96
4	2018-08-02	1,36	2,416	1,70	79,038	32,71
5	2018-08-03	0,67	0,994	2,26	34,60	34,95

2.2 AVERAGE CALCULATION

Test No.	Burn Rate (Kg/hr)	(E) Ave. Emission Rate g/hr	(OHE) %	Heat Output (BTU/HR)	CSA B415.1 CO emission g/min
2	0,95	0,320	79.4	14111	0,62
1	1,07	0,489	80.8	16177	0,67
3	1,55	0,760	76.0	22127	1,06
4	2,42	1,364	72.8	33038	1,32
Weighted particulate emission average of 4 test runs: 0.65 grams per hour.					
Weighted average HHV efficiency of 4 test runs: 77.8 %.					
Average Co 0.87 gr/min					

2.3 TEST FACILITY CONDITIONS

Run Number	Room Temperature		Barometric pressure		Relative humidity		Air Velocity	
	Before (F)	After (F)	Before (in.Hg)	After (in.Hg)	Before (%)	After (%)	Before (ft/min)	After (ft/min)
1	79	83	29,943	29,825	45,8	38	42	40
2	81	87	29,943	29,825	50	41	42	41
3	84	89	29,825	29,678	47	46	41	43
4	83	87	29,766	29,796	62,3	48,6	44	42
5	83	89	29,914	29,825	53,5	43,1	44	43

2.4 FUEL QUALITIES

Run Number	Pre-test Load			Test Load						
	Loading Weight Wet Basis (lbs)	Moisture Content Dry Basis (%)	Coal bed Weight (lbs)	Weight Wet Basis (lbs)	Density Wet Basis (lbs/cuft)	Moisture Content Dry Basis (%)	Piece Length (in.)	Number of 2X4's	Number of 4x4's	Number of Spacers
1	25,09	21,44	3,3	16,42	6,700	19,50	21,5	2	2	12
2	26,07	20,17	3.6	16,63	6,789	19,65	20,75	2	2	12
3	26,39	20,50	3,4	16,63	6,789	19,78	21	2	2	12
4	25,14	20,31	3.8	16,52	6,744	20,11	21,25	2	2	12
5	26,38	21,10	3,4	16,46	6,720	19,89	21,5	2	2	12

2.5 DILUTION TUNNEL FLOW RATE MEASUREMENTS AND SAMPLING DATA (ASTM E2515)

Average dilution tunnel measurements				Sample Data			
Run Number	Burn Rate (Min)	Volumetric Flow Rate (dscf/min)	Total Temperatures (°R)	Volume sampled (DSCF)		Particulate catch (mg)	
				1	2	1	2
1	351	311,05	549,40	59,838	58,811	1,60	1,40
2	397	313,03	552,64	68,715	67,031	1,10	1,10
3	244	313,61	559,47	41,019	40,856	1,70	1,50
4	155	319,86	570,09	26,200	25,974	1,70	1,90
5	376	309,62	554,37	61,923	61,093	2,10	2,10

2.6 DILUTION TUNNEL DUAL TRAIN PRECISION

Run Number	Sample Ratio		Total Emission (g)		
	Train 1	Train 2	Train 1	Train 2	% Deviation
1	1824,59	1856,47	3,02	2,70	5,55%
2	1808,51	1853,96	2,09	2,14	1,29%
3	1865,49	1872,90	3,27	2,91	5,85%
4	1892,34	1908,75	3,32	3,73	5,83%
5	1880,02	1905,56	4,15	4,21	0,70%

2.7 GENERAL SUMMARY OF RESULTS

Run Number	Burn Rate (kg/hr)	Average Surface Temperature (F)	Change in surface Temperature (F)	Initial Draft (in. H ² O)	static pressure tunnel (in. H ² O)	Primary Air Setting	Run Time (min)
1	1,065	306,43	-80,5	0,053	0,200	minimum setting	351
2	0,953	292,28	-74,0	0,055	0,200	minimum setting	397
3	1,549	355,76	-48,7	0,058	0,190	medium setting	244
4	2,416	373,95	-43,7	0,064	0,200	Full open	155
5	0,994	339,03	-63,2	0,057	0,200	Medium low setting	376

3 PROCESS DESCRIPTION

3.1 DISCUSSION

The unit was delivered by the client and received in a good condition. Three Preliminary runs were done at the lab to ensure repeatability of testing done by manufacturer at his location before official test series. Four runs have been done for weighted average with the optional convection fan at "ON" position. One confirmation test was done without the optional convection fan.

3.2 UNIT DIMENSIONS

Baffle

- Location: between top of combustion chamber and hearth
- Restriction: 1.75-inch X 21.5-inch at the front of the unit
- Dimensions: cover the hearth area minus the restriction at the front
- Material: Vermiculite 1 inch thick.

Bricks

- Inside firebox refractory Soapstone 1¼ inch. thick cover all the right side, back and bottom, a second door without glass is located on the left side of the stove.

Flue gas exhaust

- Location: top flue
- Dimensions: 6 in. diameter
- Material: Cast Iron

Gasket

- Glass holder: maniglass
- Glass: ¼ fiberglass Gasket Round
- Door gasket against facing: fiberglass 3/8 round inch diameter
- Refer to appendix 6 for complete list and location of each gaskets

Overall unit dimension

- Overall dimensions: 30.5-inch-wide x 20.5-inch-deep x 30.5 inch high
- Usable volume: 2.45 cuft

Convection fan

- Convection fan blower:
 - Free air : 150 CFM 110-120V (ref. : PT#93-57600)

Catalyst (appendix 6 for details):

- Applied Ceramics – P/N WF-4150001076
- Cell density: 50 CPSI
- Material: 16 Ga SS430 or 304
- Location: appendix 6 p.4 details for temperature sensor location

3.3 AIR SUPPLY SYSTEM

Description

- Primary air: Window wash design in cast iron channel fully gasketed on the top and bottom of the combustion chamber. Air intake on the middle-left side of the unit (if facing door of stove)
- Secondary air: secondary tube design with air intake coming from the bottom rear of unit, then up through a steel riser tube to the secondary air tube.

Characterization

The following table shows the inlet and outlet sections of each system. The air introduction system number is referred to on a set of drawings in Appendix 6.

AIR INTRODUCTION SYSTEM		INLET (1) sq. in.			OUTLET
Identification	Type	Imin	Imax	Controlled	(sq. in.)
APPENDIX 14 SHARED and PA	Primary	(Air control Slide) 0.164	(Air control Slide) 3.44	yes	(air Wash) 3.872
APPENDIX 14 SHARED and SA	Secondary	(riser Opening) 1.08	(riser Opening) 1.08	No	(Secondary Tube Holes) 2.21
Appendix 14 TA	Pilot	Controlled by primary	Controlled by primary	Yes	(orifice) 0.476

* This section would be filled by measuring and comparing with the manufacturer's drawings included in the test report.

Legend

Identification: Tag name referred to on drawings in Appendix 14, section airflow pattern

Type: Characterization of air intake

Imin: Minimum air intake of a particular air channel

Imax: Maximum air intake of a particular air channel

Controlled: Determines if a provision for air control is present

Outlet: Total air outlet of a particular air channel

3.4 OPERATION DURING TEST

Run #1

This run was performed on July 30th 2018. It lasted 351 minutes and a 1.07 kg/hr burn rate was obtained & emission at 0.49 gr/hr. The optional convection fan Option was at on position during the entire test. The air inlet was fully close during the test

Run #2

This run was performed on July 31st 2018. It lasted 397 minutes and a 0.95 kg/hr burn rate was obtained & emission at 0.32 gr/hr. The optional convection fan Option was at on position during the entire test. The air inlet was fully close during the test, this is the second attempt to burn less than 0.8kg/hr. After two attempts this wood stove cannot reach the burn rate of 0.8kg/hr

Run #3

This run was performed on August 1st 2018. It lasted 244 minutes and a 1.54 kg/hr burn rate was obtained & emission at 0.76 gr/hr. The optional convection fan Option was at on position during the entire test. The air inlet was at the medium setting during the test. Category 3 burn rate been achieved.

Run #4

This run was performed on August 2nd 2018. It lasted 155 minutes and a 2.42 kg/hr burn rate was obtained & emission at 1.36 gr/hr. The optional convection fan Option was at on position during the entire test. The air inlet was fully during the test. Category 4 burn rate been achieved.

Run #5

This run was performed on August 3rd 2018. It lasted 376 minutes and a 0.99 kg/hr burn rate was obtained & emission at 0.67 gr/hr. The optional convection fan Option was at OFF position during the entire test. The air inlet was at the medium setting during the test. Category 3 burn rate been achieved.

- Details: Refer to the front page of each test run data sheets found in appendix for the detailed test sequence showing air supply settings and adjustments, fuel bed adjustments and operational specifics of the test unit.

Test fuel cribs

- Type of wood: Douglas fir, grade c or better, 19 to 25% dry basis moisture content
- Description: for each test, description of the fuel crib is found on the front page of each test run data sheet together with photograph in appendix.

3.5 START-UP OPERATION

The complete manufacturer's firing procedure of each burn rate category is fully described in appendix 13.

3.6 SAMPLING LOCATIONS

Particulate samples are collected from the dilution tunnel at a point 15 feet from the tunnel entrance. The tunnel has two elbows and two mixing baffles in the system ahead of the sampling section. The sampling section is a continuous 15 foot section of 8 inch diameter pipe straight over its entire length. Tunnel velocity pressure is determined by a standard pitot tube located 48 inches from the beginning of the sampling section. Thermocouple is installed on the pitot tube to measure the dry bulb temperature. MC is assumed, as allowed, to be 4%. Tunnel samplers are located 56 inches downstream of the pitot tube and 16 inches upstream from the end of this section.

3.7 DRAWINGS

Various drawings of the stack gas sampling train and of dilution tunnel system are found in Appendix 1.

3.8 EMISSIONS EFFICIENCY TESTING EQUIPMENT LIST

The complete test equipment list together with all corresponding calibration data can be found in Appendix 3.

4 SAMPLING METHODS

4.1 PARTICULATE SAMPLING

Particulates were sampled in strict accordance with ASTM E2515. This method uses two identical sampling systems with Gelman A/E 61631 binder free (or equivalent), 47 mm diameter filters. The dryers used in the sample systems are filled with "Drierite" before each test run.

5 QUALITY ASSURANCE

5.1 INSTRUMENT CALIBRATION

5.1.1 GAS METERS

At the conclusion of each test program the gas meters are verified using the reference dry gas meter. This process involves sampling the train operation for 1 cubic foot of volume. With readings made to .01 fr', the resolution is 1 %, giving an accuracy higher than the 2% required by the standard.

5.1.2 SCALES

Before each test program, the different scales used are checked with traceable calibration weights to ensure their accuracy.

5.1.3 GAS ANALYZERS

The continuous analyzers are zeroed and spanned before each test with NBS traceable gases. A mid-scale multi-component calibration gas is then analyzed (values are recorded). At the conclusion of a test, the instruments are checked again with zero, span and calibration gases (values are recorded only). The drift in each meter is then calculated and must not exceed 5% of the scale used for the test.

5.2 TEST METHOD PROCEDURES

5.2.1 LEAK CHECK PROCEDURES

Before and after each test, each sample train is tested for leaks. Leakage rates are measured and must not exceed 0.02 CFM or 4% of the sampling rate. Leak checks are performed checking the entire sampling train. Pre-test and post-test leak checks are conducted with a vacuum of 5 inches of mercury. Vacuum is monitored during each test and the highest vacuum reached is then used for the post-test vacuum value. If leakage limits are not met, the test run is rejected. During these tests, the vacuum is typically less than 2 inches of mercury. Thus, leakage rates reported are expected to be much higher than actual leakage during the tests.

5.2.2 TUNNEL VELOCITY FLOW MEASUREMENT

The tunnel velocity is calculated from a center point pitot tube signal multiplied by an adjustment factor. This factor is determined by a traverse of the tunnel as prescribed in EPA Method 1. Final tunnel velocities and flow rates are calculated from EPA Method 2, Equation 6.9 and 6.10. (Tunnel cross sectional area is the average from both lines of traverse.)

Pitot tubes are cleaned before each test and leak checks are conducted after each test.

5.2.3 PM SAMPLING PROPORTIONALITY (ASTM E2515)

Proportionalities were calculated in accordance with ASTM E2515. The data and results are found in appendix.

APPENDIX 1: Raw data, forms and results

Paramètres

Tous les facteurs de corrections et autres paramètres qui peuvent être modifiés par l'utilisateur du fichier sont regroupés ici.

Code verrouillage:

HEA

Description du test

Test standard	EPA
Run #	1
Date	30-07-2018
Technicien	M.M
Project #	P-20174

Description de l'unité

Manufacturier	HEARTHSTONE	
Modèle	MANCHESTER	
Combustion system	Cat	
Appliance type	WOODSTOVE	
Firebox volume	2,45	cu ft.
Appliance weight empty	N.A	lbs
Appliance weight full	N.A	lbs

Paramètres du test

Logging time	1	min
Manufacturer's rated heat output	N.A	BTU/h Donnée fournie par le manufacturier
Targeted category	1	
Targeted output	N.A	BTU/h
Cp steel	N.A	BTU/lb-°F

Échantillonnage

Blank sampling rate	0,20	cuft/min
Internal probe diameter	0,18	in.
Calibration Factor (DGM #1):	0,988	Dimensionless
Equipment number (DGM #1):	EM 178	
Calibration Factor (DGM #2):	0,991	Dimensionless
Equipment number (DGM #2):	EM 179	
Calibration Factor (DGM #3):	0,996	Dimensionless
Equipment number (DGM #3):	EM 070	Dimensionless

Tunnel

Targeted tunnel flow rate	300	scfm
Tunnel diameter	8	in.
Molecular weight	28,78	May be assumed to be 28,78 (EPA) Si B-415 = 29
Pitot tube type	Standard	
Pitot tube coefficient	0,99	Dimensionless

Project nu.	P-20174
Date	30-07-2018
Technicien	M.M

Fuel data

Fuel type	Dimension	
Fuel specie	D. Fir	
HHV	19810,0	kJ/kg
%C	48,7	
%H	6,9	
%O	43,9	
%Ash	0,5	
HHV	8519,2	Btu/lb
LHV	7451,0	Btu/lb

Default Fuel Values		
	D. Fir	Oak/Maple
HHV	19 810	19 887
%C	48,73	50
%H	6,87	6,6
%O	43,9	42,9
%Ash	0,5	0,5
HHV (Btu/lb)	8519	8552
LHV (Btu/lb)	7451	7480

	Start	End
Barometer (kPa):	101,4	101
Barometer (in.Hg):	29,943409	29,82528877
Dry Bulb (F):	81,14	83
Humidity (%):	45,8	38
Air velocity (ft/min)	42	40

DGM #1	Final:	26182,233	cuft
	Initial:	26118,431	cuft
DGM #2	Final:	24547,597	cuft
	Initial:	24485,307	cuft
DGM room			

	Final:	741398,250	Liter
	Initial:	739591,580	Liter
	Final:	695110,510	Liter
	Initial:	693346,680	Liter
	Final:	165,600	cuft
	Initial:	33,480	cuft

Numéro de la ligne dans "Raw data" à partir duquel les données du VRAI test commencent

208

Autres données à rentrer: dans preload data, load data, traverse et filter set weight

Project nu.	P-20174
Date	30-07-2018
Technicien	M.M

Tunnel Traverse Worksheet (for velocity calculations)

Static Pressure: 0,2 in. H2O
 Barometer: 29,900 in. Hg

Pour un tunnel de 12" et plus, prendre 6 lectures

	TUNNEL VELOCITY	TUNNEL TEMP	SQUARE ROOT
	In. wc	°F	
A center			0,0000
B center			0,0000
A1			0,0000
A2			0,0000
A3			0,0000
A4			0,0000
A5			0,0000
A6			0,0000
B1			0,0000
B2			0,0000
B3			0,0000
B4			0,0000
B5			0,0000
B6			0,0000
AVERAGE	#DIV/0!	#DIV/0!	0,0000

PITOT CONSTANT=
0,968

Pour un tunnel moins de 12", prendre 4 lectures

	TUNNEL VELOCITY	TUNNEL TEMP	SQUARE ROOT
	In. wc	°F	
A center	0,061	73,78	0,2470
B center	0,060	72,92	0,2449
A1	0,050	73,79	0,2236
A2	0,054	73,64	0,2324
A3	0,071	73,45	0,2665
A4	0,051	73,41	0,2258
B1	0,050	72,760	0,2236
B2	0,071	72,760	0,2665
B3	0,052	72,890	0,2280
B4	0,050	72,930	0,2236
AVERAGE	0,0570	73,2330	0,2382

Project nu.	P-20174
Date	30-07-2018
Technicien	M.M

Filter set weight

	System 1 (g) 1st hour				System 1 (g)				System 2 (g)				Ambient blank (g)	Date	Heure
	probe	front	back	gasket	probe	front	back	gasket	probe	front	back	gasket	Filter		
Number	10	126	127	11	39	128	129	24	43	130	131	28	132		
Before (1)															
Before (2)															
Before (3)															
Before (4)															
Before (5)	94,6407	0,1239	0,1240	35,5215	110,2783	0,1271	0,1258	35,2807	109,1651	0,1282	0,1294	35,4070	0,1272	2018-07-27	18:00
Before (6)	94,6408	0,1240	0,1240	35,5216	110,2784	0,1272	0,1257	35,2808	109,1651	0,1281	0,1295	35,4069	0,1272	2018-07-30	09:00
After (1)	94,6426	0,1245	0,1230	35,5262	110,2788	0,1272	0,1253	35,2839	109,1660	0,1281	0,1289	35,4107	0,1276	2018-07-30	19:00
After (2)	94,6416	0,1240	0,1227	35,5245	110,2784	0,1270	0,1249	35,2822	109,1653	0,1281	0,1289	35,4088	0,1274	2018-08-03	08:00
After (3)	94,6410	0,1240	0,1227	35,5240	110,2784	0,1270	0,1249	35,2822	109,1653	0,1281	0,1289	35,4088	0,1273	2018-08-08	08:00
After (4)	94,6410	0,1240	0,1227	35,5240	110,2784	0,1270	0,1249	35,2822	109,1653	0,1281	0,1289	35,4088	0,1273	2018-08-09	08:00
After (5)															
After (6)	94,6410	0,1240	0,1227	35,5240	110,2784	0,1270	0,1249	35,2822	109,1653	0,1281	0,1289	35,4088	0,1273	2018-08-09	08:00
Difference	0,0002	0,0000	-0,0013	0,0024	0,0000	-0,0002	-0,0008	0,0014	0,0002	0,0000	-0,0006	0,0019	0,0001		
Total (mg)		1,3				1,7				1,5			0,1		
Total ajusté (mg)		1,20				1,60				1,40					

Project nu.	P-20174
Date	30-07-2018
Technicien	M.M

SFBA EPA EMISSION RESULTS

RESULTS

Average emission rate: 0,5 g/hr

Burn Rate : 1,065 Dry kg/hr

Test Duration: 351 min

PRESSURE FACTOR: DGM 1 0,97772
 DGM 2 0,98140
 DGM 3 0,99881

BAROMETRIC PRESSURE
 Average: 29,884349 in Hg
 Start: 29,943409 in Hg
 End: 29,825289 in Hg

TEMPERATURE FACTORS DGM 1 0,97044
 DGM 2 0,97039
 DGM 3 0,97291

DGM CONTROLLER VALUES

DGM 1 Final: 26182,233 Cuft
 Initial: 26118,431 Cuft

VOLUMES SAMPLED DGM 1 59,838 SCft
 DGM 2 58,811 SCft
 DGM 3 127,844 SCft

DGM 2 Final: 24547,597 Cuft
 Initial: 24485,307 Cuft

DGM #3 Final: 165,600 Cuft
 Initial: 33,480 Cuft

TOTAL TUNNEL VOLUME : 109180

TEMPERATURES

SAMPLE RATIOS
 Sample Train 1: 1824,593
 Sample Train 2: 1856,467

DGM 1 544,084 °R
 DGM 2 544,109 °R

Patriculate concentration
 Sample Train 1 **0,000028** g/dscf
 Sample Train 2 **0,000026** g/dscf
 Room **0,000001** g/dscf

CALIBRATION FACTORS

DGM 1 0,9885
 DGM 2 0,9914
 DGM #3 0,9958

TUNNEL FLOW RATE: 311,055 Dscfm

TOTAL EMISSIONS
 Sample Train 1 **3,02** g
 Sample Train 2 **2,70** g

PARTICULATE CATCH
 Total Sample Train 1: 1,70 mg
 Total Sample Train 2: 1,50 mg
 Total Sample Train 1 1st hour: 1,30 mg

EMISSION RATES
 Sample Train 1 **0,52** g/hr
 Sample Train 2 **0,46** g/hr

1st hour emission rate **2,37** g/hr

DEVIATION: 5,55%

Cs Train 1 Train 2
 2,841E-05 2,5506E-05

* Elapsed	* Weight	* CO	* CO ₂	* O ₂	*1 Flue Gas	*2 Room Temp	*3 Tunnel Dry Bulb	*4 Unit Top	*5 Unit Back	*6 Unit R.Side	*7 Unit L.Side	*8 Unit Bottom	*9 Catalyst	Mass flow 1 Reading	DGM 1 Inlet T	DGM 1 Outlet T	Filter 1 Temp	Mass flow 2 Reading	DGM 2 Inlet T	DGM 2 Outlet T	Filter 2 Temp	
Time min	Raw data row	Remaining lbs	%	%	%	°F	°F	°F	°F	°F	°F	°F	°F	cuft/min	°F	°F	°F	cuft/min	°F	°F	°F	
0,00	208,00	16,4	0,2	3,4	0,0	292,5	79,0	115,4	381,4	310,4	436,7	290,3	250,1	497,4	0,17	81,04	80,18	82,22	0,17	80,62	79,80	81,09
1,0	209,0	16,3	0,4	4,4	0,0	321,6	79,1	95,7	378,5	309,1	434,5	288,5	249,8	593,2	0,17	81,11	80,12	82,19	0,17	80,69	79,79	81,08
2,0	210,0	16,1	0,1	8,6	0,0	370,7	79,3	96,8	380,0	311,8	431,8	286,6	249,1	740,1	0,17	81,15	80,13	82,22	0,17	80,76	79,79	81,14
3,0	211,0	15,9	0,1	12,3	0,0	414,1	79,2	99,2	392,5	318,3	428,5	284,5	249,4	895,3	0,17	81,16	80,12	82,26	0,17	80,79	79,80	81,21
4,0	212,0	15,7	0,1	14,9	0,0	445,5	79,3	100,5	409,9	326,4	425,0	283,0	249,4	994,4	0,17	81,18	80,13	82,28	0,17	80,84	79,82	81,23
5,0	213,0	15,5	0,4	14,1	0,0	376,0	79,4	92,0	417,9	329,9	421,9	281,3	249,3	954,1	0,17	81,22	80,13	82,15	0,17	80,87	79,84	81,13
6,0	214,0	15,5	0,1	7,7	0,0	336,3	79,0	90,9	419,7	330,4	418,4	279,4	248,9	902,2	0,17	81,22	80,14	82,18	0,17	80,92	79,88	81,21
7,0	215,0	15,4	0,1	6,3	0,0	315,5	79,3	89,7	418,3	330,7	415,2	277,9	248,8	844,8	0,17	81,22	80,15	82,19	0,17	80,94	79,89	81,24
8,0	216,0	15,3	0,0	6,1	0,0	302,3	79,3	88,9	415,3	330,5	412,3	275,6	249,1	810,1	0,17	81,22	80,17	82,19	0,17	80,95	79,92	81,30
9,0	217,0	15,3	0,0	6,2	0,0	293,5	79,2	88,8	411,4	329,2	409,1	273,4	248,5	795,2	0,17	81,23	80,17	82,20	0,17	80,95	79,92	81,34
10,0	218,0	15,2	0,0	6,4	0,0	287,4	79,0	87,6	407,0	328,0	405,7	270,6	248,3	791,2	0,17	81,25	80,20	82,21	0,17	81,00	79,96	81,36
11,0	219,0	15,1	0,0	6,6	0,0	284,3	79,1	87,9	402,5	326,4	401,9	268,1	247,5	794,7	0,17	81,25	80,21	82,21	0,17	81,00	79,97	81,38
12,0	220,0	15,1	0,1	6,8	0,0	281,5	79,0	88,5	398,6	324,9	398,5	265,4	246,7	799,2	0,17	81,23	80,24	82,23	0,17	81,01	80,01	81,38
13,0	221,0	15,0	0,1	7,0	0,0	280,2	79,3	88,2	394,2	323,8	395,1	262,6	245,2	803,1	0,17	81,22	80,22	82,23	0,17	81,03	80,05	81,38
14,0	222,0	15,0	0,1	7,2	0,0	278,7	79,1	88,6	390,4	321,8	391,3	259,8	245,8	807,0	0,17	81,23	80,27	82,24	0,17	81,05	80,09	81,39
15,0	223,0	14,9	0,1	7,4	0,0	277,9	78,9	88,4	386,6	320,8	387,6	257,0	245,4	807,8	0,17	81,20	80,29	82,27	0,17	81,08	80,12	81,41
16,0	224,0	14,8	0,1	7,6	0,0	277,7	78,9	88,6	383,1	318,5	384,2	253,9	243,7	813,5	0,17	81,23	80,30	82,30	0,17	81,08	80,14	81,41
17,0	225,0	14,7	0,1	7,9	0,0	278,6	79,3	87,4	379,9	316,9	380,9	251,3	244,2	823,4	0,17	81,21	80,32	82,27	0,17	81,07	80,16	81,41
18,0	226,0	14,6	0,1	8,2	0,0	278,8	78,9	88,0	376,7	315,4	377,9	248,6	243,4	833,6	0,17	81,21	80,33	82,28	0,17	81,09	80,20	81,42
19,0	227,0	14,6	0,1	8,3	0,0	279,5	78,9	87,6	373,9	314,3	374,7	245,8	243,1	839,5	0,17	81,13	80,35	82,30	0,17	81,01	80,20	81,44
20,0	228,0	14,5	0,1	8,5	0,0	280,0	79,2	88,0	371,5	313,1	371,6	243,5	242,7	842,4	0,17	81,11	80,35	82,30	0,17	81,01	80,21	81,45
21,0	229,0	14,4	0,1	8,8	0,0	280,7	79,4	88,6	369,5	311,9	368,4	241,2	242,5	847,6	0,17	81,13	80,35	82,30	0,17	81,04	80,23	81,46
22,0	230,0	14,3	0,1	9,3	0,0	283,6	78,9	88,4	368,1	310,7	365,3	239,0	241,6	855,6	0,17	81,19	80,40	82,31	0,17	81,07	80,25	81,44
23,0	231,0	14,2	0,1	10,2	0,0	286,6	79,2	89,0	362,2	309,9	362,2	237,0	242,0	832,7	0,17	81,22	80,43	82,31	0,17	81,10	80,27	81,45
24,0	232,0	14,1	0,1	12,3	0,0	289,1	79,3	88,5	369,8	309,2	359,5	234,9	241,1	822,4	0,17	81,26	80,46	82,30	0,17	81,13	80,30	81,45
25,0	233,0	14,0	0,1	10,8	0,0	289,1	79,0	88,7	369,6	308,2	356,8	233,2	240,6	853,7	0,17	81,27	80,47	82,32	0,17	81,16	80,31	81,44
26,0	234,0	13,9	0,1	9,4	0,0	291,9	78,9	88,8	369,2	308,1	354,6	231,2	240,1	882,5	0,17	81,27	80,50	82,32	0,17	81,17	80,35	81,44
27,0	235,0	13,8	0,1	11,6	0,0	295,0	78,9	88,7	372,1	307,5	352,2	229,5	239,6	849,2	0,17	81,24	80,52	82,30	0,17	81,18	80,37	81,42
28,0	236,0	13,7	0,1	12,1	0,0	292,4	79,2	88,7	376,7	307,0	350,4	227,9	238,8	830,4	0,17	81,22	80,55	82,30	0,17	81,18	80,39	81,43
29,0	237,0	13,7	0,1	10,9	0,0	289,8	78,9	89,7	381,5	306,6	348,3	226,3	238,0	847,7	0,17	81,20	80,57	82,31	0,17	81,18	80,41	81,46
30,0	238,0	13,6	0,1	10,2	0,0	290,2	79,1	88,6	385,5	306,7	346,3	225,0	237,6	877,7	0,17	81,16	80,56	82,30	0,17	81,15	80,41	81,46
31,0	239,0	13,5	0,1	10,3	0,0	290,6	79,4	88,1	388,9	306,4	344,7	223,9	237,7	861,5	0,17	81,18	80,57	82,29	0,17	81,14	80,41	81,46
32,0	240,0	13,4	0,1	11,8	0,0	292,5	79,2	88,9	394,4	306,0	343,1	222,6	237,1	849,3	0,17	81,20	80,57	82,29	0,17	81,13	80,42	81,49
33,0	241,0	13,3	0,2	13,8	0,0	295,0	79,3	89,7	401,1	305,9	341,4	221,7	236,3	865,9	0,17	81,23	80,60	82,30	0,17	81,17	80,44	81,46
34,0	242,0	13,1	0,5	14,7	0,0	300,6	79,3	89,2	406,5	306,3	340,0	221,0	236,0	888,7	0,17	81,24	80,63	82,30	0,17	81,18	80,47	81,48
35,0	243,0	13,0	1,0	14,8	0,0	305,4	79,4	89,4	409,8	307,2	338,9	221,1	235,7	902,1	0,17	81,22	80,62	82,29	0,17	81,19	80,50	81,47
36,0	244,0	12,9	1,0	14,3	0,0	306,7	79,6	89,4	413,1	308,0	337,9	221,5	233,9	887,7	0,17	81,24	80,65	82,30	0,17	81,23	80,55	81,47
37,0	245,0	12,8	1,7	14,3	0,0	305,6	79,1	89,0	416,9	308,5	336,6	222,7	234,0	865,1	0,17	81,15	80,67	82,34	0,17	81,20	80,59	81,48
38,0	246,0	12,7	0,1	14,3	0,0	304,4	79,5	88,7	420,8	308,8	335,9	224,0	233,4	858,1	0,17	81,14	80,66	82,33	0,17	81,18	80,62	81,48
39,0	247,0	12,6	0,1	13,9	0,0	303,2	79,2	89,9	424,5	309,0	335,1	225,2	232,5	858,0	0,17	81,14	80,70	82,32	0,17	81,21	80,65	81,51
40,0	248,0	12,5	0,1	13,7	0,0	302,9	79,5	88,7	427,9	308,9	334,8	226,9	231,8	858,1	0,17	81,20	80,70	82,32	0,17	81,25	80,65	81,52
41,0	249,0	12,4	0,1	13,4	0,0	302,1	79,4	89,5	430,9	309,0	334,4	228,7	231,4	855,9	0,17	81,28	80,72	82,35	0,17	81,32	80,68	81,54
42,0	250,0	12,3	0,1	13,3	0,0	300,6	79,5	89,4	433,6	309,1	334,4	230,6	230,6	848,2	0,17	81,34	80,71	82,33	0,17	81,31	80,67	81,53
43,0	251,0	12,2	0,1	13,2	0,0	301,3	79,8	89,4	435,7	308,9	334,3	232,5	230,1	834,8	0,17	81,37	80,75	82,38	0,17	81,35	80,70	81,53
44,0	252,0	12,0	0,1	13,3	0,0	301,7	79,7	88,7	437,9	308,4	334,5	234,5	229,9	824,3	0,17	81,39	80,76	82,35	0,17	81,37	80,69	81,51
45,0	253,0	11,9	0,1	13,5	0,0	302,9	79,8	89,5	440,1	308,1	334,8	236,2	229,5	823,3	0,17	81,42	80,79	82,36	0,17	81,37	80,70	81,52
46,0	254,0	11,8	0,2	13,6	0,0	304,6	79,5	88,8	441,8	308,1	335,0	237,9	228,0	825,7	0,17	81,42	80,81	82,38	0,17	81,40	80,71	81,52
47,0	255,0	11,7	0,3	13,9	0,0	306,3	80,0	89,3	443,6	308,4	335,2	239,8	227,8	833,1	0,17	81,43	80,82	82,41	0,17	81,39	80,72	81,53
48,0	256,0	11,6	0,5	14,0	0,0	308,8	79,6	89,9	446,4	308,8	335,6	242,0	227,7	852,1	0,17	81,44	80,83	82,43	0,17	81,42	80,74	81,54
49,0	257,0	11,5	0,5	14,7	0,0	311,6	79,7	89,3	448,2	309,5	336,1	244,0	226,9	865,7	0,17	81,47	80,88	82,43	0,17	81,44	80,76	81,56
50,0	258,0	11,4	1,2	14,6	0,0	312,6	79,9	89,3	450,5	310,2	336,6	246,1	226,0	867,4	0,17	81,49	80,88	82,43	0,17	81,46	80,75	81,53
51,0	259,0	11,2	1,7	14,5	0,0	313,7	79,9	91,4	452,7	311,0	337,1	247,9	224,5	862,8	0,17	81,55	80,90	82,46	0,17	81,50	80,78	81,57
52,0	260,0	11,1	2,0	14,6	0,0	313,8	79,8	91,3	454,9	312,1	337,5	250,3	224,5	859,1	0,17	81,53	80,89	82,47	0,17	81,51	80,80	81,60
53,0	261,0	11																				

79,0	287,0	8,0	0,7	15,0	0,0	314,7	80,5	91,5	510,2	331,0	373,1	305,8	209,2	891,1	0,17	82,18	81,44	82,98	0,17	82,20	81,37	82,67
80,0	288,0	7,8	0,8	15,0	0,0	314,2	80,6	90,9	511,6	331,2	374,2	307,2	208,3	892,8	0,17	82,22	81,46	82,99	0,17	82,20	81,37	82,69
81,0	289,0	7,7	0,9	15,0	0,0	315,2	80,5	91,2	513,3	331,3	375,4	308,6	208,0	893,6	0,17	82,27	81,49	83,01	0,17	82,25	81,38	82,77
82,0	290,0	7,6	1,0	15,0	0,0	315,5	80,8	90,7	514,6	331,3	376,9	309,4	206,9	893,1	0,17	82,32	81,51	83,03	0,17	82,27	81,40	82,80
83,0	291,0	7,5	1,1	15,1	0,0	315,4	80,6	91,3	515,5	331,7	377,9	310,4	207,0	891,2	0,17	82,33	81,53	83,08	0,17	82,30	81,42	82,89
84,0	292,0	7,4	1,3	15,0	0,0	314,7	80,9	92,2	517,6	332,0	379,4	310,9	205,5	888,2	0,17	82,39	81,55	83,09	0,17	82,32	81,44	82,94
85,0	293,0	7,3	1,5	15,0	0,0	314,8	80,8	92,1	518,7	332,4	380,4	311,8	205,2	886,0	0,17	82,41	81,58	83,12	0,17	82,37	81,46	83,03
86,0	294,0	7,2	1,6	14,9	0,0	314,5	80,9	91,2	519,7	333,0	381,5	313,1	205,2	884,5	0,17	82,44	81,59	83,14	0,17	82,39	81,49	83,07
87,0	295,0	7,1	1,4	15,0	0,0	314,4	80,3	91,4	521,0	333,2	382,7	313,9	204,6	884,7	0,17	82,47	81,62	83,15	0,17	82,39	81,48	83,08
88,0	296,0	7,0	1,1	15,0	0,0	312,8	80,3	91,5	522,1	333,4	383,8	314,9	204,2	884,3	0,17	82,50	81,63	83,19	0,17	82,42	81,51	83,14
89,0	297,0	6,9	0,9	15,0	0,0	311,8	80,6	91,5	523,3	334,1	384,9	315,6	203,9	884,4	0,17	82,55	81,65	83,24	0,17	82,46	81,52	83,16
90,0	298,0	6,8	0,8	15,0	0,0	310,8	81,0	91,4	523,7	334,8	386,2	316,3	203,4	884,4	0,17	82,60	81,69	83,26	0,17	82,52	81,56	83,22
91,0	299,0	6,7	0,4	15,0	0,0	309,7	81,1	91,1	524,9	335,2	387,4	317,6	202,7	883,8	0,17	82,64	81,71	83,27	0,17	82,53	81,56	83,27
92,0	300,0	6,6	0,3	14,9	0,0	308,9	81,2	91,3	525,0	335,7	388,7	318,0	202,3	879,2	0,17	82,61	81,72	83,29	0,17	82,52	81,59	83,29
93,0	301,0	6,6	0,1	14,8	0,0	307,7	81,3	91,3	525,5	335,9	390,0	318,4	200,8	869,9	0,17	82,65	81,74	83,30	0,17	82,55	81,62	83,31
94,0	302,0	6,5	0,0	14,5	0,0	304,4	81,1	91,2	525,0	336,2	390,8	319,8	201,3	854,6	0,17	82,64	81,75	83,37	0,17	82,54	81,66	83,36
95,0	303,0	6,4	0,0	13,9	0,0	301,3	81,0	90,8	525,3	336,4	391,9	320,9	200,6	836,1	0,17	82,68	81,76	83,37	0,17	82,57	81,66	83,39
96,0	304,0	6,3	0,0	13,6	0,0	298,7	81,0	89,7	525,8	335,8	393,0	321,7	199,8	820,2	0,17	82,75	81,78	83,40	0,17	82,57	81,66	83,40
97,0	305,0	6,2	0,0	13,4	0,0	296,1	81,4	90,8	525,8	334,9	394,3	322,3	199,0	808,6	0,17	82,76	81,81	83,44	0,17	82,62	81,67	83,46
98,0	306,0	6,2	0,0	13,3	0,0	294,3	81,1	91,8	525,6	333,1	395,2	323,0	198,9	800,8	0,17	82,76	81,83	83,47	0,17	82,65	81,70	83,54
99,0	307,0	6,1	0,0	13,2	0,0	291,8	81,5	91,1	525,6	332,4	396,3	323,6	198,0	796,0	0,17	82,81	81,86	83,49	0,17	82,70	81,73	83,56
100,0	308,0	6,0	0,0	13,1	0,0	290,6	81,2	91,2	524,8	330,9	397,4	323,5	197,6	793,2	0,17	82,85	81,92	83,51	0,17	82,77	81,80	83,61
101,0	309,0	6,0	0,0	13,0	0,0	288,7	81,2	90,9	523,9	329,8	398,1	324,0	197,2	788,4	0,17	82,87	81,92	83,54	0,17	82,81	81,82	83,64
102,0	310,0	5,9	0,0	12,9	0,0	287,6	81,5	90,6	522,5	328,6	399,1	324,1	197,0	785,4	0,17	82,90	81,92	83,55	0,17	82,80	81,82	83,64
103,0	311,0	5,8	0,0	13,1	0,0	286,2	81,7	89,0	521,3	327,8	400,2	323,8	195,1	783,9	0,17	82,93	81,96	83,57	0,17	82,81	81,85	83,68
104,0	312,0	5,8	0,0	13,1	0,0	285,8	81,9	91,0	519,3	326,7	400,9	323,9	195,8	779,4	0,17	82,99	81,97	83,59	0,17	82,85	81,89	83,72
105,0	313,0	5,7	0,0	13,2	0,0	282,8	81,7	89,1	517,1	325,7	401,8	323,4	194,3	776,0	0,17	83,13	82,04	83,63	0,17	82,95	81,97	83,74
106,0	314,0	5,6	0,0	13,1	0,0	281,1	81,6	89,5	515,2	324,8	402,5	323,2	194,0	767,0	0,17	83,30	82,08	83,64	0,17	83,07	82,01	83,79
107,0	315,0	5,6	0,0	13,2	0,0	280,6	82,1	91,1	513,1	323,6	403,1	323,0	194,0	760,3	0,17	83,41	82,11	83,67	0,17	83,16	82,05	83,82
108,0	316,0	5,5	0,0	13,3	0,0	279,9	81,9	90,6	511,1	322,4	403,7	322,9	192,2	756,2	0,17	83,48	82,17	83,70	0,17	83,26	82,11	83,88
109,0	317,0	5,4	0,0	13,3	0,0	278,6	82,1	89,4	508,9	321,7	404,5	322,8	192,5	754,4	0,17	83,63	82,22	83,74	0,17	83,38	82,18	83,91
110,0	318,0	5,4	0,0	13,3	0,0	278,2	82,3	90,1	506,9	320,6	404,9	322,6	192,5	755,3	0,17	83,74	82,29	83,76	0,17	83,50	82,21	83,97
111,0	319,0	5,3	0,0	13,4	0,0	277,6	82,4	91,1	504,9	320,2	405,6	323,1	192,5	756,2	0,17	83,83	82,34	83,79	0,17	83,61	82,27	84,01
112,0	320,0	5,2	0,0	13,6	0,0	276,6	82,2	90,3	503,0	319,7	405,9	322,7	191,5	757,1	0,17	83,80	82,42	83,83	0,17	83,63	82,35	84,05
113,0	321,0	5,2	0,0	13,6	0,0	275,3	82,1	89,7	501,5	318,7	406,6	322,5	191,1	756,6	0,17	83,84	82,45	83,87	0,17	83,70	82,41	84,13
114,0	322,0	5,1	0,0	13,5	0,0	275,4	82,2	90,2	499,8	318,5	406,9	322,5	191,1	758,0	0,17	83,88	82,47	83,90	0,17	83,71	82,44	84,14
115,0	323,0	5,0	0,0	13,5	0,0	275,0	82,1	89,8	498,5	317,6	407,6	322,4	190,5	757,6	0,17	83,91	82,52	83,92	0,17	83,76	82,47	84,19
116,0	324,0	5,0	0,0	13,4	0,0	273,9	81,9	89,4	497,2	317,0	408,1	322,2	190,2	757,2	0,17	83,91	82,55	83,93	0,17	83,78	82,52	84,21
117,0	325,0	4,9	0,0	13,5	0,0	273,1	82,2	90,0	495,9	316,5	408,6	322,3	189,6	759,0	0,17	83,90	82,58	83,94	0,17	83,80	82,55	84,23
118,0	326,0	4,8	0,0	13,5	0,0	271,9	82,6	90,2	494,9	316,1	409,1	322,1	188,4	760,2	0,17	83,92	82,62	83,98	0,17	83,83	82,59	84,30
119,0	327,0	4,8	0,0	13,4	0,0	271,1	82,5	90,2	493,2	315,7	409,7	322,6	188,2	759,0	0,17	83,95	82,67	84,02	0,17	83,88	82,64	84,36
120,0	328,0	4,7	0,0	13,4	0,0	269,7	82,4	90,1	492,1	315,6	410,3	322,6	188,0	757,4	0,17	84,04	82,71	84,06	0,17	83,97	82,69	84,39
121,0	329,0	4,6	0,0	13,3	0,0	269,2	82,6	89,3	491,6	315,0	410,7	322,8	187,5	757,3	0,17	84,12	82,77	84,07	0,17	84,05	82,74	84,41
122,0	330,0	4,6	0,0	13,3	0,0	267,0	82,6	91,2	491,4	314,6	411,0	323,1	186,3	758,2	0,17	84,12	82,80	84,11	0,17	84,08	82,78	84,48
123,0	331,0	4,5	0,0	13,0	0,0	265,9	82,2	90,5	490,7	314,3	411,6	323,1	186,4	759,2	0,17	84,08	82,85	84,14	0,17	84,09	82,85	84,53
124,0	332,0	4,5	0,0	12,9	0,0	263,9	82,3	89,9	489,9	314,0	412,3	323,1	186,2	761,0	0,17	84,13	82,90	84,14	0,17	84,14	82,87	84,55
125,0	333,0	4,4	0,0	12,6	0,0	261,9	82,3	89,5	489,5	313,8	412,9	323,2	185,7	767,0	0,17	84,20	82,93	84,18	0,17	84,17	82,89	84,55
126,0	334,0	4,4	0,0	12,6	0,0	260,4	82,8	90,3	489,0	313,5	413,4	323,3	185,6	783,6	0,17	84,28	83,00	84,22	0,17	84,24	82,94	84,60
127,0	335,0	4,3	0,0	12,7	0,0	258,2	82,8	90,4	489,1	313,1	414,1	323,3	185,0	792,9	0,17	84,44	83,07	84,25	0,17	84,37	83,02	84,66
128,0	336,0	4,3	0,0	12,6	0,0	257,1	82,7	90,6	488,8	312,9	414,4	323,0	185,1	786,0	0,17	84,54	83,10	84,28	0,17	84,45	83,08	84,74
129,0	337,0	4,2	0,0	12,7	0,0	256,4	83,0	89,8	488,7	312,3	414,8	322,8	184,9	771,4	0,17	84,64	83,19	84,32	0,17	84,59	83,16	84,75
130,0	338,0	4,2	0,0	12,6	0,0	255,8	83,0	90,4	488,5	311,9	415,0	322,7	183,9	766,1	0,17	84,73	83,24	84,33	0,17	84,65	83,22	84,80
131,0	339,0	4,2	0,0	12,8	0,0	256,9	82,9	89,6	488,2	311,7	415,0	322,4	183,3	791,1	0,17	84,64	83,27	84,41	0,17	84,60	83,26	84,82
132,0	340,0	4,1	0,1	13,1	0,0	258,1	82,9	89,5	487,0	311,3	415,3	322,1	183,5	799,5	0,17	84,56	83,32	84,43	0,17	84,58	83,29	84,84
133,0	341,0	4,1	0,0	13,0	0,0	256,5	82,6	89,0	485,6	311,0	415,5	321,7	183,4	782,1	0,17	84,61	83,36	84,44	0,17	84,64	83,33	84,8

162,0	370,0	3,3	0,1	12,1	0,0	227,2	82,9	88,2	425,7	292,6	414,7	306,8	179,6	725,2	0,17	85,05	84,41	85,09	0,17	85,30	84,38	85,54
163,0	371,0	3,2	0,1	12,0	0,0	226,9	83,3	88,6	423,5	292,2	414,6	306,7	179,9	726,6	0,17	84,98	84,43	85,09	0,17	85,24	84,40	85,54
164,0	372,0	3,2	0,1	12,0	0,0	226,1	83,5	89,1	421,0	291,6	414,4	306,4	179,9	728,2	0,17	85,02	84,46	85,11	0,17	85,28	84,44	85,54
165,0	373,0	3,2	0,1	12,0	0,0	225,5	83,5	89,0	418,6	291,3	414,7	305,7	180,1	729,8	0,17	85,05	84,46	85,12	0,17	85,29	84,44	85,55
166,0	374,0	3,2	0,1	11,9	0,0	225,3	83,6	89,2	416,7	290,9	414,7	305,8	179,8	732,3	0,17	85,15	84,51	85,13	0,17	85,33	84,45	85,58
167,0	375,0	3,1	0,1	12,0	0,0	225,5	83,6	89,0	415,2	290,8	414,5	305,5	180,0	736,2	0,17	85,24	84,54	85,17	0,17	85,39	84,51	85,64
168,0	376,0	3,1	0,1	12,0	0,0	225,6	84,9	88,8	412,8	290,4	414,2	305,1	180,0	742,1	0,17	85,29	84,57	85,17	0,17	85,40	84,53	85,66
169,0	377,0	3,1	0,1	11,9	0,0	225,7	83,9	90,1	411,0	290,1	414,3	304,7	180,8	744,2	0,17	85,32	84,60	85,21	0,17	85,45	84,54	85,70
170,0	378,0	3,1	0,1	11,8	0,0	225,3	83,8	89,1	409,1	289,9	414,0	303,8	180,4	743,5	0,17	85,35	84,63	85,19	0,17	85,50	84,58	85,71
171,0	379,0	3,1	0,1	11,8	0,0	225,2	83,8	88,8	407,0	289,7	413,8	303,1	180,2	743,4	0,17	85,27	84,62	85,23	0,17	85,44	84,60	85,69
172,0	380,0	3,0	0,1	11,8	0,0	225,2	83,6	88,5	405,3	289,2	413,2	302,2	180,1	743,2	0,17	85,22	84,65	85,23	0,17	85,42	84,62	85,70
173,0	381,0	3,0	0,1	11,7	0,0	225,0	83,1	88,7	403,5	288,8	413,2	301,7	180,0	742,1	0,17	85,24	84,66	85,24	0,17	85,43	84,63	85,72
174,0	382,0	3,0	0,1	11,8	0,0	224,4	83,4	88,8	401,8	288,3	412,8	300,9	180,1	740,9	0,17	85,28	84,72	85,26	0,17	85,47	84,66	85,79
175,0	383,0	3,0	0,1	11,7	0,0	224,2	83,4	88,7	400,1	287,8	412,5	300,2	180,4	740,8	0,17	85,28	84,74	85,26	0,17	85,47	84,68	85,80
176,0	384,0	3,0	0,1	11,6	0,0	224,1	83,6	88,6	398,4	287,4	412,5	299,7	180,5	741,9	0,17	85,30	84,77	85,26	0,17	85,48	84,70	85,81
177,0	385,0	2,9	0,1	11,5	0,0	224,7	83,5	88,5	396,5	287,1	412,1	299,2	180,7	748,0	0,17	85,31	84,81	85,28	0,17	85,50	84,72	85,82
178,0	386,0	2,9	0,1	11,4	0,0	225,4	83,3	88,5	395,0	286,8	411,9	297,9	180,4	753,2	0,17	85,33	84,83	85,30	0,17	85,50	84,73	85,82
179,0	387,0	2,9	0,1	11,4	0,0	226,1	83,4	88,7	392,9	287,0	411,5	297,5	181,0	754,7	0,17	85,32	84,85	85,32	0,17	85,51	84,75	85,82
180,0	388,0	2,9	0,1	11,4	0,0	225,8	83,5	88,4	391,4	286,8	411,2	296,7	180,7	747,8	0,17	85,31	84,90	85,31	0,17	85,55	84,80	85,85
181,0	389,0	2,8	0,1	11,3	0,0	224,2	83,5	88,9	389,8	286,2	411,2	296,3	181,0	744,7	0,17	85,35	84,92	85,35	0,17	85,56	84,82	85,88
182,0	390,0	2,8	0,1	11,3	0,0	223,4	83,5	88,9	388,7	285,8	410,7	295,4	180,6	743,1	0,17	85,36	84,93	85,34	0,17	85,59	84,85	85,89
183,0	391,0	2,8	0,1	11,3	0,0	222,8	83,2	88,7	387,3	285,2	410,6	294,6	181,0	741,6	0,17	85,36	84,98	85,36	0,17	85,57	84,86	85,89
184,0	392,0	2,8	0,1	11,3	0,0	222,3	83,3	88,6	386,3	284,8	410,1	293,9	180,7	740,7	0,17	85,36	84,96	85,38	0,17	85,56	84,87	85,89
185,0	393,0	2,8	0,1	11,4	0,0	221,6	83,6	88,7	385,0	284,5	410,0	293,9	180,9	742,0	0,17	85,42	85,02	85,38	0,17	85,60	84,90	85,91
186,0	394,0	2,7	0,1	11,3	0,0	222,3	83,4	89,1	383,6	284,2	409,1	292,9	180,9	750,1	0,17	85,38	85,01	85,42	0,17	85,58	84,91	85,93
187,0	395,0	2,7	0,1	11,2	0,0	223,9	83,4	88,5	381,9	284,1	409,1	292,7	181,1	756,2	0,17	85,39	85,04	85,40	0,17	85,60	84,94	85,94
188,0	396,0	2,7	0,1	11,1	0,0	224,1	83,5	88,9	380,8	283,8	408,7	291,6	180,6	759,6	0,17	85,44	85,08	85,42	0,17	85,66	84,98	85,97
189,0	397,0	2,7	0,1	11,0	0,0	224,8	83,4	88,8	379,2	283,6	408,0	290,5	180,9	760,2	0,17	85,46	85,09	85,46	0,17	85,69	84,99	85,99
190,0	398,0	2,7	0,1	11,0	0,0	225,7	83,6	88,8	377,6	283,8	407,6	289,9	181,2	758,8	0,17	85,52	85,15	85,46	0,17	85,74	85,02	86,02
191,0	399,0	2,6	0,1	11,0	0,0	225,4	83,6	88,5	376,4	283,4	407,0	289,2	181,1	754,9	0,17	85,58	85,16	85,48	0,17	85,75	85,04	86,03
192,0	400,0	2,6	0,1	11,0	0,0	224,4	83,6	88,8	375,3	283,0	406,4	288,4	181,6	753,1	0,17	85,64	85,21	85,49	0,17	85,82	85,08	86,05
193,0	401,0	2,6	0,1	11,1	0,0	223,5	83,9	89,0	374,3	282,6	405,9	287,4	181,5	752,4	0,17	85,68	85,24	85,53	0,17	85,85	85,10	86,08
194,0	402,0	2,6	0,1	11,1	0,0	222,8	84,1	89,0	373,1	282,1	405,6	286,9	181,7	751,6	0,17	85,72	85,27	85,55	0,17	85,91	85,14	86,08
195,0	403,0	2,6	0,1	11,0	0,0	222,3	84,1	89,1	372,1	281,9	405,3	286,1	181,6	750,5	0,17	85,80	85,32	85,59	0,17	86,00	85,18	86,13
196,0	404,0	2,6	0,1	11,0	0,0	221,9	84,0	89,2	371,2	281,3	404,7	285,6	181,4	749,6	0,17	85,76	85,34	85,61	0,17	86,01	85,23	86,15
197,0	405,0	2,5	0,1	11,0	0,0	221,7	84,2	88,9	370,0	281,2	404,3	285,5	181,7	748,8	0,17	85,82	85,38	85,64	0,17	86,03	85,23	86,17
198,0	406,0	2,5	0,1	11,1	0,0	222,2	84,1	89,1	368,8	280,5	403,9	285,0	181,7	748,7	0,17	85,86	85,41	85,65	0,17	86,07	85,26	86,18
199,0	407,0	2,5	0,1	11,0	0,0	221,3	84,1	89,0	367,6	280,1	403,4	284,4	181,6	747,9	0,17	85,90	85,45	85,69	0,17	86,12	85,29	86,24
200,0	408,0	2,5	0,1	11,0	0,0	221,2	84,0	89,1	367,0	279,4	402,8	284,0	181,8	747,1	0,17	85,93	85,49	85,69	0,17	86,16	85,33	86,25
201,0	409,0	2,5	0,1	11,0	0,0	221,2	84,2	89,1	365,9	278,9	402,3	283,8	181,5	746,8	0,17	85,96	85,52	85,71	0,17	86,15	85,34	86,24
202,0	410,0	2,5	0,1	11,0	0,0	220,9	84,0	89,1	365,0	278,3	401,9	283,1	182,1	747,1	0,17	85,91	85,53	85,75	0,17	86,16	85,38	86,27
203,0	411,0	2,4	0,1	11,0	0,0	220,2	84,0	88,7	363,8	277,9	401,4	282,8	182,0	747,7	0,17	85,87	85,55	85,77	0,17	86,13	85,40	86,26
204,0	412,0	2,4	0,1	11,0	0,0	220,3	84,0	89,3	363,1	277,6	401,1	282,3	181,8	748,2	0,17	85,82	85,56	85,77	0,17	86,11	85,41	86,27
205,0	413,0	2,4	0,1	11,0	0,0	219,8	84,0	89,6	362,3	277,2	400,6	281,6	182,0	748,2	0,17	85,83	85,59	85,81	0,17	86,14	85,46	86,32
206,0	414,0	2,4	0,1	11,0	0,0	219,8	83,6	89,3	361,4	277,1	399,9	281,3	182,1	747,9	0,17	85,83	85,58	85,82	0,17	86,14	85,48	86,33
207,0	415,0	2,3	0,1	11,0	0,0	219,1	84,0	89,0	360,5	275,8	399,2	280,8	182,0	746,7	0,17	85,84	85,61	85,84	0,17	86,16	85,51	86,35
208,0	416,0	2,3	0,1	11,0	0,0	218,9	83,8	89,0	359,5	275,0	399,1	280,5	182,7	746,2	0,17	85,81	85,61	85,87	0,17	86,14	85,53	86,35
209,0	417,0	2,3	0,1	11,0	0,0	218,9	84,3	88,8	358,5	274,0	398,7	280,0	182,7	746,2	0,17	85,80	85,63	85,86	0,17	86,13	85,52	86,33
210,0	418,0	2,3	0,1	11,0	0,0	218,5	84,1	88,8	357,7	273,7	398,3	279,8	182,3	746,4	0,17	85,83	85,64	85,90	0,17	86,14	85,56	86,35
211,0	419,0	2,3	0,1	11,0	0,0	218,6	84,2	88,9	357,0	272,9	397,9	279,3	182,8	746,4	0,17	85,88	85,67	85,91	0,17	86,17	85,58	86,36
212,0	420,0	2,3	0,1	10,9	0,0	218,1	84,4	88,9	356,0	272,3	397,4	279,1	182,9	746,6	0,17	85,87	85,66	85,92	0,17	86,18	85,60	86,35
213,0	421,0	2,2	0,1	10,9	0,0	218,5	84,6	89,3	355,2	271,6	397,1	278,3	182,7	747,1	0,17	85,85	85,67	85,92	0,17	86,16	85,62	86,39
214,0	422,0	2,2	0,1	10,9	0,0	218,3	84,4	88,9	354,5	271,1	396,4	277,8	182,6	747,7	0,17	85,87	85,68	85,97	0,17	86,18	85,64	86,39
215,0	423,0	2,2	0,1	10,9	0,0	218,2	84,1	89,0	353,8	271,1	395,9	277,4	182,5	747,8	0,17	85,80	85,70	85,98	0,17	86,14	85,65	86,38
216,0	424,0	2,2	0,1	10,9	0,0	217,9	83,8	89,0	353,1	270,9	395,4	277,0	182,5	747,9	0,17	85,73	85,68	85,95	0,17	86,		

245,0	453,0	1,6	0,1	10,4	0,0	208,6	84,0	87,9	337,4	255,6	380,2	258,8	185,1	695,2	0,17	85,26	85,62	85,78	0,17	85,60	85,57	86,01
246,0	454,0	1,6	0,1	10,4	0,0	208,7	83,8	87,9	336,8	255,3	379,7	258,2	184,9	695,6	0,17	85,24	85,63	85,77	0,17	85,61	85,58	86,01
247,0	455,0	1,6	0,1	10,3	0,0	208,7	83,9	88,1	336,1	254,7	379,2	257,7	185,4	696,6	0,17	85,27	85,62	85,78	0,17	85,59	85,59	86,03
248,0	456,0	1,6	0,1	10,3	0,0	208,2	84,2	87,9	335,6	254,2	378,6	256,7	185,7	697,3	0,17	85,29	85,64	85,78	0,17	85,61	85,58	86,02
249,0	457,0	1,6	0,1	10,4	0,0	208,0	84,2	88,1	334,9	254,0	378,2	256,1	186,0	698,8	0,17	85,31	85,64	85,76	0,17	85,61	85,59	86,00
250,0	458,0	1,5	0,1	10,4	0,0	207,5	84,0	88,1	334,2	253,5	377,6	255,6	185,7	699,7	0,17	85,34	85,66	85,74	0,17	85,63	85,60	85,99
251,0	459,0	1,5	0,1	10,4	0,0	207,9	84,1	87,9	333,8	253,2	376,9	254,7	185,7	699,6	0,17	85,35	85,66	85,74	0,17	85,65	85,60	85,96
252,0	460,0	1,5	0,1	10,4	0,0	207,9	83,9	87,9	333,3	252,9	376,5	254,3	186,0	699,8	0,17	85,36	85,66	85,72	0,17	85,65	85,61	85,99
253,0	461,0	1,5	0,1	10,4	0,0	207,6	84,0	88,0	333,0	252,7	376,3	253,9	186,5	701,3	0,17	85,36	85,68	85,75	0,17	85,66	85,62	86,00
254,0	462,0	1,5	0,1	10,5	0,0	207,7	84,2	88,1	332,4	252,2	376,0	253,5	187,0	702,4	0,17	85,32	85,67	85,74	0,17	85,62	85,61	85,97
255,0	463,0	1,4	0,1	10,5	0,0	207,5	84,1	88,2	332,0	252,1	375,7	252,7	187,0	702,1	0,17	85,31	85,68	85,72	0,17	85,62	85,62	85,96
256,0	464,0	1,4	0,1	10,6	0,0	207,1	84,1	88,1	331,7	251,7	375,3	252,5	187,0	702,0	0,17	85,30	85,67	85,72	0,17	85,62	85,64	85,97
257,0	465,0	1,4	0,1	10,7	0,0	207,2	84,3	88,5	331,3	251,3	374,6	252,2	187,2	701,1	0,17	85,34	85,68	85,72	0,17	85,64	85,65	85,99
258,0	466,0	1,4	0,1	10,7	0,0	206,7	84,4	88,5	330,9	251,1	374,3	251,7	187,2	699,8	0,17	85,38	85,67	85,72	0,17	85,65	85,66	85,99
259,0	467,0	1,4	0,1	10,7	0,0	206,6	84,4	88,2	330,4	251,0	374,0	251,5	188,0	697,5	0,17	85,43	85,70	85,74	0,17	85,71	85,67	85,99
260,0	468,0	1,4	0,1	10,6	0,0	206,3	83,7	88,4	330,2	250,9	373,3	251,0	187,1	697,7	0,17	85,38	85,67	85,72	0,17	85,66	85,69	85,97
261,0	469,0	1,3	0,1	10,7	0,0	205,2	84,2	88,7	330,0	250,4	373,3	250,8	188,0	694,0	0,17	85,38	85,66	85,73	0,17	85,64	85,67	86,00
262,0	470,0	1,3	0,1	10,6	0,0	205,1	84,3	88,1	329,9	250,1	373,3	250,4	188,0	692,5	0,17	85,41	85,67	85,74	0,17	85,65	85,65	85,98
263,0	471,0	1,3	0,1	10,5	0,0	204,6	83,6	88,5	329,7	249,9	372,7	250,1	188,4	690,9	0,17	85,42	85,67	85,74	0,17	85,67	85,66	85,98
264,0	472,0	1,3	0,1	10,3	0,0	204,3	84,3	88,5	329,6	249,8	372,3	250,0	188,4	689,7	0,17	85,45	85,68	85,75	0,17	85,69	85,67	85,97
265,0	473,0	1,3	0,1	10,3	0,0	204,4	84,1	88,5	329,3	249,6	371,8	249,7	188,6	689,8	0,17	85,46	85,67	85,75	0,17	85,70	85,67	85,97
266,0	474,0	1,3	0,1	10,3	0,0	204,0	84,4	88,2	329,2	249,3	371,5	249,6	188,8	690,0	0,17	85,48	85,70	85,75	0,17	85,74	85,69	85,99
267,0	475,0	1,3	0,1	10,3	0,0	204,2	84,0	87,9	329,2	249,1	371,3	249,1	188,6	690,9	0,17	85,47	85,69	85,75	0,17	85,74	85,69	85,97
268,0	476,0	1,2	0,1	10,4	0,0	204,3	84,4	88,2	329,0	249,0	371,1	249,0	189,7	692,2	0,17	85,44	85,71	85,72	0,17	85,74	85,71	85,97
269,0	477,0	1,2	0,1	10,4	0,0	203,9	84,4	88,2	328,7	248,6	370,7	248,6	189,5	693,6	0,17	85,47	85,72	85,73	0,17	85,75	85,72	85,94
270,0	478,0	1,2	0,1	10,4	0,0	204,2	84,5	88,0	328,2	248,3	370,3	248,3	189,9	695,0	0,17	85,49	85,72	85,74	0,17	85,78	85,73	85,96
271,0	479,0	1,2	0,1	10,5	0,0	204,1	84,5	88,1	328,2	248,2	369,9	248,1	189,9	695,9	0,17	85,54	85,76	85,74	0,17	85,81	85,74	85,97
272,0	480,0	1,2	0,1	10,4	0,0	203,9	84,2	87,9	327,8	248,1	369,9	247,7	190,2	695,5	0,17	85,60	85,76	85,75	0,17	85,85	85,76	85,97
273,0	481,0	1,2	0,1	10,4	0,0	203,9	84,2	87,9	327,5	247,9	369,5	247,5	190,4	694,9	0,17	85,64	85,81	85,75	0,17	85,89	85,76	85,96
274,0	482,0	1,1	0,1	10,4	0,0	203,8	84,3	88,2	327,2	247,9	369,4	247,4	189,7	694,7	0,17	85,63	85,79	85,78	0,17	85,88	85,77	85,99
275,0	483,0	1,1	0,1	10,3	0,0	203,9	84,5	87,9	326,7	247,4	368,8	247,1	190,6	695,0	0,17	85,57	85,78	85,76	0,17	85,83	85,77	85,97
276,0	484,0	1,1	0,1	10,3	0,0	204,6	84,2	87,8	326,4	247,2	368,7	246,7	190,8	695,3	0,17	85,53	85,78	85,76	0,17	85,82	85,76	85,96
277,0	485,0	1,1	0,1	10,3	0,0	204,4	84,0	87,6	326,0	247,0	368,5	246,5	190,3	695,6	0,17	85,52	85,78	85,78	0,17	85,80	85,75	85,93
278,0	486,0	1,1	0,1	10,3	0,0	204,5	84,3	88,0	325,6	246,7	367,8	246,0	190,4	695,2	0,17	85,49	85,76	85,75	0,17	85,76	85,72	85,94
279,0	487,0	1,1	0,1	10,4	0,0	204,0	84,3	87,8	325,4	246,6	367,5	246,0	191,0	693,8	0,17	85,45	85,76	85,75	0,17	85,72	85,75	85,93
280,0	488,0	1,0	0,1	10,4	0,0	204,3	84,2	88,4	325,3	246,4	367,2	245,7	191,2	691,4	0,17	85,45	85,74	85,75	0,17	85,73	85,72	85,95
281,0	489,0	1,0	0,1	10,4	0,0	203,7	84,3	88,2	325,1	246,2	366,9	245,4	190,8	689,8	0,17	85,44	85,74	85,77	0,17	85,72	85,74	85,95
282,0	490,0	1,0	0,1	10,1	0,0	203,4	84,3	88,0	325,0	246,2	366,5	245,3	191,4	687,6	0,17	85,43	85,74	85,78	0,17	85,70	85,72	85,93
283,0	491,0	1,0	0,1	10,1	0,0	203,4	84,0	88,0	324,9	245,9	366,2	245,0	191,3	686,3	0,17	85,44	85,77	85,75	0,17	85,73	85,75	85,93
284,0	492,0	1,0	0,1	10,1	0,0	203,9	84,3	88,2	324,8	245,7	365,4	244,8	191,1	685,5	0,17	85,43	85,76	85,76	0,17	85,72	85,74	85,95
285,0	493,0	1,0	0,1	10,0	0,0	203,5	84,2	88,1	324,6	245,3	364,8	244,8	191,0	684,1	0,17	85,44	85,76	85,77	0,17	85,72	85,77	85,96
286,0	494,0	1,0	0,1	10,0	0,0	203,5	84,2	88,0	324,5	245,1	364,5	244,3	191,0	684,3	0,17	85,49	85,77	85,76	0,17	85,75	85,77	85,95
287,0	495,0	0,9	0,1	9,9	0,0	203,9	83,8	88,2	324,3	245,0	363,9	244,4	190,7	685,7	0,17	85,53	85,79	85,74	0,17	85,78	85,77	85,95
288,0	496,0	0,9	0,1	9,9	0,0	203,5	84,0	88,1	324,2	244,5	363,3	244,1	191,1	686,9	0,17	85,50	85,79	85,74	0,17	85,76	85,77	85,95
289,0	497,0	0,9	0,1	10,0	0,0	203,1	84,3	88,4	324,0	244,3	362,7	244,1	191,4	687,4	0,17	85,48	85,78	85,76	0,17	85,77	85,76	85,95
290,0	498,0	0,9	0,1	9,9	0,0	203,6	84,3	88,4	323,8	243,9	362,2	243,9	191,3	686,4	0,17	85,46	85,79	85,74	0,17	85,76	85,77	85,92
291,0	499,0	0,9	0,1	9,9	0,0	203,1	84,2	88,0	323,7	243,6	361,7	243,8	192,0	686,3	0,17	85,42	85,78	85,74	0,17	85,73	85,77	85,93
292,0	500,0	0,9	0,1	9,8	0,0	203,1	84,3	88,0	323,2	243,3	361,3	243,7	191,8	686,4	0,17	85,45	85,79	85,77	0,17	85,75	85,78	85,94
293,0	501,0	0,8	0,1	9,8	0,0	203,0	84,3	87,8	322,8	243,0	360,8	243,8	191,0	686,6	0,17	85,49	85,79	85,76	0,17	85,79	85,79	85,94
294,0	502,0	0,8	0,1	9,8	0,0	203,4	84,3	88,1	322,6	242,8	360,4	243,8	191,8	688,0	0,17	85,49	85,82	85,75	0,17	85,79	85,81	85,92
295,0	503,0	0,8	0,1	9,8	0,0	203,3	84,2	88,1	322,5	242,5	359,8	243,6	191,5	688,4	0,17	85,50	85,84	85,75	0,17	85,82	85,80	85,94
296,0	504,0	0,8	0,1	9,9	0,0	203,1	84,4	88,3	322,1	242,2	359,1	243,7	191,9	689,8	0,17	85,52	85,83	85,74	0,17	85,82	85,82	85,94
297,0	505,0	0,8	0,1	9,9	0,0	203,1	84,4	88,2	322,1	241,8	358,4	243,5	192,3	692,3	0,17	85,51	85,84	85,75	0,17	85,83	85,80	85,96
298,0	506,0	0,8	0,1	9,8	0,0	203,5	84,6	88,4	321,9	241,7	358,0	243,4	192,5	694,3	0,17	85,51	85,84	85,75	0,17	85,81	85,81	85,99
299,0	507,0	0,7	0,1	9,9	0,0	203,3	84,3	88,0	321,8	241,4	357,1	243,1	192,1	695,8	0,17	85,52	85,83	85,79	0,17	85,78	85,80	

328,0	536,0	0,3	0,1	8,7	0,0	202,7	84,9	89,7	307,5	235,3	340,9	236,9	192,3	685,9	0,17	86,25	86,15	86,09	0,17	86,44	86,17	86,33
329,0	537,0	0,3	0,1	8,7	0,0	202,8	84,8	89,3	307,2	235,1	340,6	236,9	191,8	686,0	0,17	86,29	86,18	86,10	0,17	86,47	86,17	86,34
330,0	538,0	0,3	0,1	8,6	0,0	202,4	85,1	89,3	306,3	234,6	339,9	236,7	192,3	684,8	0,17	86,32	86,21	86,12	0,17	86,51	86,21	86,36
331,0	539,0	0,3	0,1	8,5	0,0	202,0	84,8	89,1	305,9	234,3	339,2	236,3	191,7	683,6	0,17	86,32	86,23	86,13	0,17	86,53	86,23	86,38
332,0	540,0	0,3	0,1	8,5	0,0	201,8	85,0	89,7	305,4	233,8	338,6	236,1	192,0	682,4	0,17	86,30	86,23	86,14	0,17	86,52	86,25	86,39
333,0	541,0	0,3	0,1	8,4	0,0	202,0	84,9	89,3	304,9	233,3	338,3	235,9	192,3	680,9	0,17	86,30	86,27	86,16	0,17	86,56	86,27	86,39
334,0	542,0	0,2	0,1	8,3	0,0	201,8	85,1	89,8	304,3	233,1	337,7	235,7	191,8	679,8	0,17	86,31	86,27	86,16	0,17	86,55	86,27	86,41
335,0	543,0	0,2	0,1	8,4	0,0	201,8	84,9	89,4	303,7	232,7	337,1	235,5	191,5	679,2	0,17	86,35	86,29	86,16	0,17	86,60	86,28	86,40
336,0	544,0	0,2	0,1	8,3	0,0	201,3	85,0	89,3	303,2	232,4	336,3	235,0	191,3	678,5	0,17	86,35	86,29	86,18	0,17	86,59	86,31	86,40
337,0	545,0	0,2	0,1	8,3	0,0	201,7	85,2	89,2	302,6	232,0	335,7	234,8	192,0	678,1	0,17	86,34	86,30	86,20	0,17	86,58	86,32	86,39
338,0	546,0	0,2	0,1	8,2	0,0	201,2	85,1	89,2	302,0	231,6	334,9	234,4	191,6	677,5	0,17	86,34	86,31	86,21	0,17	86,59	86,32	86,40
339,0	547,0	0,2	0,1	8,3	0,0	200,8	84,9	89,3	301,4	231,2	334,1	234,1	191,6	676,7	0,17	86,34	86,32	86,23	0,17	86,60	86,32	86,42
340,0	548,0	0,2	0,1	8,2	0,0	201,2	84,8	89,1	300,7	230,9	333,6	233,8	191,4	676,2	0,17	86,38	86,33	86,22	0,17	86,61	86,31	86,45
341,0	549,0	0,2	0,1	8,2	0,0	201,2	85,0	89,1	300,3	230,5	333,0	233,3	191,3	675,5	0,17	86,38	86,35	86,23	0,17	86,63	86,33	86,44
342,0	550,0	0,1	0,1	8,2	0,0	200,9	85,2	89,2	299,5	230,1	332,5	232,8	191,3	675,1	0,17	86,39	86,36	86,25	0,17	86,61	86,33	86,47
343,0	551,0	0,1	0,1	8,0	0,0	201,3	84,8	89,2	299,0	229,7	331,9	232,5	191,4	674,2	0,17	86,36	86,35	86,26	0,17	86,62	86,33	86,49
344,0	552,0	0,1	0,1	8,0	0,0	201,4	85,1	88,9	298,3	229,6	331,4	232,3	190,6	671,9	0,17	86,38	86,37	86,25	0,17	86,65	86,35	86,49
345,0	553,0	0,1	0,1	8,0	0,0	200,9	85,1	89,0	297,6	229,2	330,9	232,0	189,7	671,6	0,17	86,41	86,39	86,28	0,17	86,67	86,37	86,50
346,0	554,0	0,1	0,1	7,9	0,0	201,3	85,0	89,1	296,8	229,0	330,3	231,6	190,1	675,8	0,17	86,42	86,41	86,29	0,17	86,69	86,41	86,51
347,0	555,0	0,1	0,1	7,9	0,0	201,3	85,1	89,0	296,2	228,6	329,6	231,1	190,4	679,6	0,17	86,45	86,42	86,30	0,17	86,72	86,43	86,52
348,0	556,0	0,1	0,1	7,9	0,0	200,9	85,2	89,1	295,4	228,2	328,8	230,4	190,3	681,7	0,17	86,45	86,43	86,32	0,17	86,71	86,41	86,53
349,0	557,0	0,1	0,1	8,0	0,0	201,4	85,0	89,2	294,7	227,8	328,2	230,0	190,7	682,3	0,17	86,49	86,45	86,32	0,17	86,73	86,41	86,53
350,0	558,0	0,1	0,1	8,0	0,0	201,8	84,8	88,8	294,0	227,6	327,5	229,7	190,0	682,0	0,17	86,50	86,47	86,33	0,17	86,76	86,42	86,54
351,0	559,0	0,0	0,1	7,9	0,0	201,8	84,8	88,9	293,2	227,3	327,0	229,2	189,9	681,0	0,17	86,51	86,47	86,33	0,17	86,75	86,43	86,56

Manufacturer: HEARTHSTONE
 Model: MANCHESTER

Run: 1
 Project #: P-20174
 Test Duration: 351 min

	HHV	LHV
Eff	80,80%	87,33%
Comb Eff	97,37%	97,37%
HT Eff	82,98%	89,69%
Output	17 054	kJ/h
Burn Rate	1,07	kg/h
Grams CO	237	g
Input	21 106	kJ/h
MC wet	16,32	

Note: In the "Input data", "Calc. % O₂", "Fuel Properties", and "Mass Balance" columns, [e], [d], [g], [a], [b], [c], [h], [u], [w], [j], and [k] refer to their respective variables in Clauses 13.7.3

Ultimate CO₂
 CO_{2-ut} 19,64
 F_o
 1,063

Overall Heating Efficiency: 80,80%
 Combustion Efficiency: 97,37%
 Heat Transfer Efficiency: 82,98%

	Air Fuel Ratio (A/F)	
Dry Molecular Weight (M _d)	30,16	
Dry Moles Exhaust Gas (N _g):	340,52	
Air Fuel Ratio (A/F)	9,76	

Heat Output:	16 177 Btu/h	17 054 kJ/h
Heat Input:	20 021 Btu/h	21 106 kJ/h
Burn Duration:	5,85 h	
Burn Rate:	2,35 lb/h	1,065 kg/h
Stack Temp:	246,6 Deg. F	119,2 Deg. C

Date: 2018-07-30 Manufacturer: Hearthstone Model: malchester
 Project #: pJ 20174 Run: 1 Tech: MM Reviewer: JP

Moisture Meter Calibration Check:

Equipment #	Time	12%	22%
EM 191	7:00	ok	ok

Facility Conditions:

Air Velocity from less than 2 feet
 Smoke Capture Check.....
 Picture.....

	Pre-Test	Post-Test
	42 (max 50 Fpm)	(max 50 Fpm)
	ok	40
4 sides	ok	ok

Wood Heater Conditions:

Date Wood Heater Stack Cleaned.....
 Date Dilution Tunnel Cleaned.....
 Induced Draft Check (max 0.005 H2O).....
 Traverse before ignition.....
 Flow Rate 140 cfm ±10%.....

2018-07-30
2018-07-30
ok
ok

OK

Temperature System:

Ambient (65°-90°F).....
 Wood Heater Surface (±125°F).....

OK °F
OK °F

Proportional Checks:

Thermocouple check.....
 Pitot Clean.....
 Pitot verification.....

ok
ok
ok

Sampling Train ID Numbers:

Probe.....
 Filter Front.....
 Filter Back.....
 Filter Thermocouple.....
 Filter (<90°F).....

Train 1 st hour	Train 1	Train 2
10	39	43
126	128	130
127	129	131
11	SP-2412	11
ok	ok	ok

SAMPLING EQUIPMENT CHECK OUT

Date: 2018-07-30 Manufacturer: Heathston Model: manchester
 Project #: PT-20174 Run: 1 Tech: MR Reviewer: 80

Leakage Checks Tunnel Samplers

	System 1 st hour		System 1		System 2	
	Pre-Test ASTM (-15) CSA B415 (-5)	Post-Test (max test)	Pre-Test ASTM (-15) CSA B415 (-5)	Post-Test (Max test)	Pre-Test ASTM (-15) CSA B415 (-5)	Post-Test (Max test)
Unplugged Flow Rate = .25cfm						
Vacuum (inches Hg.)	- 15	- 15	- 15	- 15	- 15	- 15
Final 1minute DGM (Liter)	739590.44	741399.35	739590.51	695111.61	693345.50	741399.50
Initial 1minute DGM (Liter)	739590.44	741399.35	739590.49	695111.60	693345.50	741399.50
Change © (Liter)	0	0	0.02	0.01	0	0.06
Allowable leakage .04 x Sample rate or 0.28Lpm CSA B415 (0.56)						
Check OK	OK		OK		OK	

Leakage Checks Flue Gas Sampler

Plugged Probe	Pre Test	Post Test
Vacuum (inches Hg.)	- 5	- 5
Rotometer Reading (mml/min.)	0	0
Flow Rate (lpm)	1.5	1.5
Allowable (.02 x Sample Rate)	30	30
Check OK	OK	OK

Leakage Checks Pitot

Plugged Probe	Pre Test 3 H2o static	Pre Test 0.4-0.5 H2o velocity	Post Test 3 H2o Static	Post Test 0.4-0.5 H2o velocity
Vacuum (inches Hg.)	3	- 4	3	- 4
Check OK (no change after 15 sec.)	OK	OK	OK	OK

PRE-TEST SCALE AUDIT

Date: 2018-07-30 Manufacturer: Hearthstone Model: manchester
 Project #: PT 20124 Run: 1 Tech: mm Reviewer: [Signature]

Scale Type	Audit		Measured Weight
	Equipment #	Weight	
Platform	EM 090	44 lbs, Class F	44 lbs
Wood	EM 090	44 lbs, Class F	44 lbs
Analytical	EM 128	100 mg, Class S	100 mg
Analytical	EM 129	200 g, Class S	200 g

LIMITS OF WEIGHT RANGES

ANALYTICAL SCALE: 50%-150% of dry filter weight, ± 0.1 mg
PLATFORM SCALE: 20%-80% of ideal test load weight, ± 0.1 lbs or 1%
WOOD SCALE: 20%-80% of ideal test load weight, ± 0.01 lbs or 1%

Date: 2018-07-30 Manufacturer: Hearlthstone Model: Manchester
 Project #: PI 20174 Run: 1 Tech: MM Reviewer: DP

FOR TUNNELS < 12 in

 Barometric pressure (P_{bar}) 1014 (KPa.) Static pressure (P_q) 000 (inches w.c.)
 Inside diameter: Port A _____ Port B _____
 Tunnel cross sectional area: .1963Ft²
 Pitot tube type: Standard

Traverse Point	Position (inches)			Velocity Head Δ_p (inches H ₂ O)	Tunnel Temperature (°F)
	6 po	7 po	8 po		
A - Centroid	3.00	3.50	4	0061	73 78
B - Centroid	3.00	3.50	4	0060	72 92
A-1	0.40	0.50	0.50	0050	73 79
A-2	1.50	1.75	2	0054	73 64
A-3	4.50	5.25	6	0071	73 45
A-4	5.60	6.5	7.5	0051	73 41
B-1	0.40	0.50	0.50	0050 0050 mm	74 76
B-2	1.50	1.75	2	0071	74 76
B-3	4.50	5.25	6	0052	74 89
B-4	5.60	6.5	7.5	0050	74 93
				AVERAGE	

$$v_s = K_p C_p (\sqrt{\Delta p})_{avg} \sqrt{\frac{(T_s)_{avg}}{P_s M_s}}$$

Where,

 C_p = pitot tube coefficient, dimension less = 0.99 for standard pitot.

 Δ_p = manometer reading (inches H₂O)

 T_s = average absolute dilution tunnel temperature (°F + 460)

 P_s = absolute dilution tunnel gas pressure or $P_{bar} + P_{qg}$
 P_q = static pressure in. H₂O
 { 13.6 }

 M_s = 28.56, wet molecular weight of stack gas (alternatively, it may be measured)

 K_p = 85.49 pitot tube constant, (conversion factor for English units)

 Δ_p .avg. = average of the square roots of the velocity heads (Δ_p) measured at each traverse point.

Date: 2018-07-30 Manufacturer: Hcanth slorb Model: m allhester
 Project #: PT 20174 Run: 1 Tech: MR Reviewer: DL

Pre-Test (Adjust and Record)

	ZERO		SPAN		CAL. (Record Only)	
	Actual	Should Be	Actual	Should Be	Actual	Should Be
CO	0	0	2975	3000	1009	1000
Tolerance CO		+/- 0.02		+/- 0.15		+/- 0.05
CO ₂	0	0	1787	1800	977	1000
Tolerance CO ₂		+/- 0.02		+/- 0.5		+/- 0.5
O ₂ informative CSA B415 calculated value	na	na	na	na	na	na
	Actual	Should Be	Actual	Should Be	Actual	Should Be

Post Test (Record Only)

	Zero	Span	Cal.	Zero Drift	Limit	Span Drift	Limit	Cal. Drift	Limit	OK?	Not OK*
CO	0	2980	1005	0	0.02	0.005	0.15	0.004	0.05	✓	
CO ₂	0	1790	977	0	0.02	0.03	0.5	0.04	0.5	✓	

Date: 2018-07-30 Manufacturer: Dearborn Model: max hester
 Project #: PT 20174 Run: 1 Tech: MM Reviewer: NP

RAW DRY GAS METER READINGS

	System 1	System 2	Blank
Final (Liter)	74398.25	695110.51	165.60
Initial (Liter)	739591.58	693346.68	033.48

AMBIENT CONDITIONS

	Before	After
Barometer (kPa):	1014	1014
Dry Bulb (F):	81.14	83.06
Humidity (%):	45.8	38.3

Flow Meter

	Start	End
Flow meter reading	N/A	N/A

Flow Meter Verification

	Before	After
Flow meter Check (liters)	N/A	N/A
Scale Weight (Kg)	N/A	N/A

FUEL DATA

 Date: 2018-07-30 Manufacturer: Heartthrob Model: manchester
 Project #: PT 20174 Run: 1 Tech: mm Reviewer: DP
FUEL DESCRIPTION:

Type of wood:

PRE-TEST LOAD

Piece Size	Weight	Meter Moisture Content (% dry)*						
1 1/2 x 3 1/2 x 18 in.	1602 lbs.	213	206	216	209	21		
1 1/2 x 3 1/2 x 18 in.	152 lbs.	210	219	211	216	21		
1 1/2 x 3 1/2 x 18 in.	1636 lbs.	219	214	213	209	216		
1 1/2 x 3 1/2 x 18 in.	152 lbs.	219	216	205	213	209		
1 1/2 x 3 1/2 x 11 in.	1000 lbs.	217	210	213	210	219		
1 1/2 x 3 1/2 x 11 in.	0964 lbs.	220	221	218	216	215		
1 1/2 x 3 1/2 x 11 in.	1022 lbs.	221	22	223	218	214		
1 1/2 x 3 1/2 x 11 in.	1152 lbs.	218	219	210	219	218		
1 1/2 x 3 1/2 x 11 in.	0954 lbs.	219	217	217	218	219		
1 1/2 x 3 1/2 x 11 in.	1048 lbs.	217	219	203	216	219		
1 1/2 x 3 1/2 x 18 in.	247 1546 lbs.	228	221	239	230	231		
1 1/2 x 3 1/2 x 18 in.	1590 lbs.	219	216	210	214	213		
1 1/2 x 3 1/2 x 18 in.	1492 lbs.	219	210	211	213	219		
1 1/2 x 3 1/2 x 18 in.	1568 lbs.	206	203	204	204	209		
1 1/2 x 3 1/2 x 11 in.	0942 lbs.	220	223	216	221	224		
1 1/2 x 3 1/2 x 11 in.	1190 lbs.	204	209	20	208	206		
1 1/2 x 3 1/2 x 11 in.	1032 lbs.	214	218	209	213	212		
1 1/2 x 3 1/2 x 11 in.	0960 lbs.	220	216	216	219	210		
1 1/2 x 3 1/2 x 11 in.	1492 lbs.	220	216	208	217	213		
1 1/2 x 3 1/2 x 11 in.	092 lbs.	209	208	205	206	209		
x x in.	lbs.							
x x in.	lbs.							
x x in.	lbs.							

 TEST LOAD WEIGHT: 2509 lbs

FUEL DATA

 Date: 2018-07-30 Manufacturer: Hearthstone Model: Manchester
 Project #: PJ 20174 Run: 1 Tech: MN Reviewer: NO
FUEL DESCRIPTION:

Type of wood :

TEST LOAD

Piece Size		Weight	Meter Moisture Content (% dry)*				
1 1/2	x 3 1/2 x 2 1/2 in.	229 lbs.	191	192	193	192	191
1 1/2	x 3 1/2 x 2 1/2 in.	238 lbs.	192	191	192	193	194
3 1/2	x 3 1/2 x 4 1/2 in.	5254 lbs.	192	199	202	198	193
3 1/2	x 3 1/2 x 4 1/2 in.	5268 lbs.	191	199	191	193	192
1 1/2	x 3/4 x 5 in.	0096 lbs.				21	
1 1/2	x 3/4 x 5 in.	0114 lbs.				26	
1 1/2	x 3/4 x 5 in.	0122 lbs.				23	
1 1/2	x 3/4 x 5 in.	0116 lbs.				220	
1 1/2	x 3/4 x 5 in.	0104 lbs.				209	
1 1/2	x 3/4 x 5 in.	0122 lbs.				209	
1 1/2	x 3/4 x 5 in.	0106 lbs.				26	
1 1/2	x 3/4 x 5 in.	0096 lbs.				204	
1 1/2	x 3/4 x 5 in.	0102 lbs.				209	
1 1/2	x 3/4 x 5 in.	0102 lbs.				28	
1 1/2	x 3/4 x 5 in.	0102 lbs.				24	
1 1/2	x 3/4 x 5 in.	0104 lbs.				209	
x	x in.	lbs.					
x	x in.	lbs.					
x	x in.	lbs.					
x	x in.	lbs.					
x	x in.	lbs.					
x	x in.	lbs.					
x	x in.	lbs.					
x	x in.	lbs.					
x	x in.	lbs.					
x	x in.	lbs.					
x	x in.	lbs.					

 TEST LOAD WEIGHT: 1642 lbs Min 20%: 330 Max 25%: 416

DILUTION TUNNEL PARTICULATE SAMPLER DATA

Date: 2018-07-27 Manufacturer: Alcauld Stewart Model: Mowchester
 Project #: PI 20174 Run: 1 Tech: M.M. Reviewer: DP

		SYSTEM 1 - 1 st hour						SYSTEM 1							
Pre-test Weight Record	Date	Time	Probe & Housing Number	Front Filter Number	Back Filter Number	gaskets	Probe & Housing Number	Front Filter Number	Back Filter Number	gaskets	Probe & Housing Number	Front Filter Number	Back Filter Number	gaskets	Blanck
	2018-07-27		10	126	127	11	39	128	129	24					132
	2018-07-27	18:00	946407	01239	01240	355215	1102783	01271	01258	352807					01272
	2018-07-30	9:00	946408	01240	01240	355216	1102784	01272	01257	352808					01272

		SYSTEM 1 - 1 st hour						SYSTEM 1							
Post-test Weight Record	Date	Time	Probe & Housing Number	Front Filter Number	Back Filter Number	gaskets	Probe & Housing Number	Front Filter Number	Back Filter Number	gaskets	Probe & Housing Number	Front Filter Number	Back Filter Number	gaskets	Blanck
	2018-07-30	19:00	946426	01245	01230	355262	1102788	01272	01253	352839					01276
	2018-08-03	8:00	946416	01240	01227	355245	1102784	01270	01249	352822					01274
	2018-08-08	8:00	946410	01240	01227	355240	1102784	01270	01249	352822					01273
	2018-08-09	8:00	946410	01240	01227	355240	1102784	01270	01249	352822					01273

Date: 2018-07-27 Manufacturer: HiCar-HS-100K Model: pmavchessdor

Project #: PT 20174 Run: 1 Tech: MR Reviewer: DP

SYSTEM 2					
Pre-test Weight Record	Probe & Housing Number	Front Filter Number	Back Filter Number	gaskets	
Date	Time	43	130	131	28
2018-07-27	18:00	1091651	01282	01294	354070
2018-07-30	18:00	1091651	01281	01295	354069

SYSTEM 2					
Post-test Weight Record	Probe & Housing Number	Front Filter Number	Back Filter Number	gaskets	
Date	Time	43	130	131	28
2018-07-30	19:00	1091660	01281	01289	354107
2018-08-03	8:00	1091653	01281	01289	354088
2018-08-08	8:00	1091653	01281	01289	354088
2018-08-09	8:00	1091653	01281	01289	354088

Paramètres

Tous les facteurs de corrections et autres paramètres qui peuvent être modifiés par l'utilisateur du fichier sont regroupés ici.

Code verrouillage:

HEA

Description du test

Test standard	EPA
Run #	2
Date	31-07-2018
Technicien	M.M
Project #	P-20174

Description de l'unité

Manufacturier	HEARTHSTONE	
Modèle	MANCHESTER	
Combustion system	Cat	
Appliance type	WOODSTOVE	
Firebox volume	2,45	cu ft.
Appliance weight empty	N.A	lbs
Appliance weight full	N.A	lbs

Paramètres du test

Logging time	1	min
Manufacturer's rated heat output	N.A	BTU/h Donnée fournie par le manufacturier
Targeted category	1	
Targeted output	N.A	BTU/h
Cp steel	N.A	BTU/lb-°F

Échantillonnage

Blank sampling rate	0,20	cuft/min
Internal probe diameter	0,18	in.
Calibration Factor (DGM #1):	0,988	Dimensionless
Equipment number (DGM #1):	EM 178	
Calibration Factor (DGM #2):	0,991	Dimensionless
Equipment number (DGM #2):	EM 179	
Calibration Factor (DGM #3):	0,996	Dimensionless
Equipment number (DGM #3):	EM 070	Dimensionless

Tunnel

Targeted tunnel flow rate	300	scfm
Tunnel diameter	8	in.
Molecular weight	28,78	May be assumed to be 28,78 (EPA) Si B-415 = 29
Pitot tube type	Standard	
Pitot tube coefficient	0,99	Dimensionless

Project nu.	P-20174
Date	31-07-2018
Technicien	M.M

Fuel data

Fuel type	Dimension
Fuel specie	D. Fir
HHV	19810,0 kJ/kg
%C	48,7
%H	6,9
%O	43,9
%Ash	0,5
HHV	8519,2 Btu/lb
LHV	7451,0 Btu/lb

Default Fuel Values		
	D. Fir	Oak/Maple
HHV	19 810	19 887
%C	48,73	50
%H	6,87	6,6
%O	43,9	42,9
%Ash	0,5	0,5
HHV (Btu/lb)	8519	8552
LHV (Btu/lb)	7451	7480

	Start	End
Barometer (kPa):	101,4	101
Barometer (in.Hg):	29,943409	29,82528877
Dry Bulb (F):	79,7	86,9
Humidity (%):	50	41
Air velocity (ft/min)	42	41

DGM #1	Final:	26255,797	cuft
	Initial:	26182,309	cuft
DGM #2	Final:	24619,111	cuft
	Initial:	24547,756	cuft
DGM room			

	Final:	743481,350	Liter
	Initial:	741400,410	Liter
	Final:	697135,580	Liter
	Initial:	695115,040	Liter
	Final:	320,760	cuft
	Initial:	165,600	cuft

Numéro de la ligne dans "Raw data" à partir duquel les données du VRAI test commencent

229

Autres données à rentrer: dans preload data, load data, traverse et filter set weight

Project nu.	P-20174
Date	31-07-2018
Technicien	M.M

Tunnel Traverse Worksheet (for velocity calculations)

Static Pressure: 0,2 in. H2O
 Barometer: 29,900 in. Hg

Pour un tunnel de 12" et plus, prendre 6 lectures

	TUNNEL VELOCITY	TUNNEL TEMP	SQUARE ROOT
	In. wc	°F	
A center			0,0000
B center			0,0000
A1			0,0000
A2			0,0000
A3			0,0000
A4			0,0000
A5			0,0000
A6			0,0000
B1			0,0000
B2			0,0000
B3			0,0000
B4			0,0000
B5			0,0000
B6			0,0000
AVERAGE	#DIV/0!	#DIV/0!	0,0000

PITOT CONSTANT=
0,968

Pour un tunnel moins de 12", prendre 4 lectures

	TUNNEL VELOCITY	TUNNEL TEMP	SQUARE ROOT
	In. wc	°F	
A center	0,058	75,7	0,2408
B center	0,057	75,75	0,2387
A1	0,048	75,7	0,2191
A2	0,051	75,71	0,2258
A3	0,069	75,7	0,2627
A4	0,047	75,72	0,2168
B1	0,047	75,700	0,2168
B2	0,066	75,570	0,2569
B3	0,050	75,580	0,2236
B4	0,048	75,510	0,2191
AVERAGE	0,0541	75,6640	0,2320

Project nu.	P-20174
Date	31-07-2018
Technicien	M.M

Filter set weight

	System 1 (g) 1st hour				System 1 (g)				System 2 (g)				Ambient blank (g)	Date	Heure
	probe	front	back	gasket	probe	front	back	gasket	probe	front	back	gasket	Filter		
Number	3	711	712	16	5	713	714	21	30	730	731	26	732		
Before (1)															
Before (2)															
Before (3)															
Before (4)															
Before (5)	61,4560	0,1246	0,1250	34,7663	61,5050	0,1239	0,1284	35,4441	110,2305	0,1271	0,1271	34,6968	0,1296	2018-07-30	18:00
Before (6)	61,4559	0,1246	0,1250	34,7663	61,5051	0,1239	0,1284	35,4442	110,2306	0,1270	0,1270	34,6967	0,1297	2018-07-31	09:00
After (1)	61,4565	0,1251	0,1249	34,771	61,506	0,1235	0,1276	35,4487	110,2312	0,1272	0,1274	34,7009	0,1302	2018-07-31	19:30
After (2)	61,4560	0,1244	0,1244	34,7678	61,5052	0,1229	0,1272	35,4467	110,2307	0,1268	0,1270	34,6980	0,1298	2018-08-08	08:00
After (3)	61,4560	0,1244	0,1244	34,7678	61,5052	0,1229	0,1272	35,4467	110,2307	0,1268	0,1270	34,6980	0,1298	2018-08-09	08:00
After (4)															
After (5)															
After (6)	61,4560	0,1244	0,1244	34,7678	61,5052	0,1229	0,1272	35,4467	110,2307	0,1268	0,1270	34,6980	0,1298	2018-08-09	08:00
Difference	0,0001	-0,0002	-0,0006	0,0015	0,0001	-0,0010	-0,0012	0,0025	0,0001	-0,0002	0,0000	0,0013	0,0001		
Total (mg)		0,8				1,2				1,2			0,1		
Total ajusté (mg)		0,70				1,10				1,10					

Project nu.	P-20174
Date	31-07-2018
Technicien	M.M

SFBA EPA EMISSION RESULTS

RESULTS

Average emission rate: 0,3 g/hr
 Burn Rate : 0,953 Dry kg/hr

Test Duration: 397 min

PRESSURE FACTOR: DGM 1 0,97981
 DGM 2 0,98147
 DGM 3 0,99881

BAROMETRIC PRESSURE
 Average: 29,884349 in Hg
 Start: 29,943409 in Hg
 End: 29,825289 in Hg

TEMPERATURE FACTORS DGM 1 0,96546
 DGM 2 0,96544
 DGM 3 0,96803

DGM CONTROLLER VALUES
 DGM 1 Final: 26255,797 Cuft
 Initial: 26182,309 Cuft

VOLUMES SAMPLED DGM 1 68,715 Scft
 DGM 2 67,031 Scft
 DGM 3 149,385 Scft

DGM 2 Final: 24619,111 Cuft
 Initial: 24547,756 Cuft

DGM #3 Final: 320,760 Cuft
 Initial: 165,600 Cuft

TOTAL TUNNEL VOLUME : 124272

TEMPERATURES
 DGM 1 546,892 °R
 DGM 2 546,900 °R

SAMPLE RATIOS
 Sample Train 1: 1808,514
 Sample Train 2: 1853,961

CALIBRATION FACTORS
 DGM 1 0,9885
 DGM 2 0,9914
 DGM #3 0,9958

Paticulate concentration
 Sample Train 1 **0,000017** g/dscf
 Sample Train 2 **0,000018** g/dscf
 Room **0,000001** g/dscf

TUNNEL FLOW RATE: 313,028 Dscfm

TOTAL EMISSIONS
 Sample Train 1 **2,09** g
 Sample Train 2 **2,14** g

PARTICULATE CATCH
 Total Sample Train 1: 1,20 mg
 Total Sample Train 2: 1,20 mg
 Total Sample Train 1 1st hour: 0,80 mg

EMISSION RATES
 Sample Train 1 **0,32** g/hr
 Sample Train 2 **0,32** g/hr

1st hour emission rate **1,45** g/hr

DEVIATION: 1,29%

Cs Train 1 Train 2
 1,746E-05 1,79023E-05

Elapsed Time min	Raw data row	Weight Remaining lbs	CO %	CO ₂ %	O ₂ %	Flue Gas %	Room Temp °F	Tunnel Dry Bulb °F	Unit Top °F	Unit Back °F	Unit R.Side °F	Unit L.Side °F	Unit Bottom °F	Catalyst Down	Reading °C	Inlet T °F	Outlet T °F	Temp °F	Reading °C	Inlet T °F	Outlet T °F	Temp °F
0.00	229.00	16.5	0.2	2.5	319.4	266.3	81.0	101.6	346.4	288.2	431.3	274.2	256.9	495.7	0.17	83.02	82.68	83.00	0.17	82.71	82.23	82.85
1.0	230.00	16.5	0.1	3.5	318.5	299.3	81.1	94.8	345.8	287.7	429.3	273.2	256.3	588.9	0.17	83.05	82.69	83.04	0.16	82.79	82.24	82.86
2.0	231.00	16.4	0.0	5.1	318.1	328.1	80.9	95.8	346.8	289.7	426.9	271.6	256.6	663.7	0.17	83.03	82.68	83.08	0.17	82.79	82.25	82.88
3.0	232.00	16.2	0.0	6.7	318.0	350.3	80.6	98.3	349.9	290.8	423.9	270.0	255.4	710.6	0.17	83.06	82.67	83.10	0.16	82.80	82.25	82.95
4.0	233.00	16.1	0.0	8.8	320.0	373.6	80.9	99.7	359.6	294.9	420.8	268.7	255.8	798.6	0.17	83.05	82.69	83.14	0.16	82.84	82.29	83.05
5.0	234.00	16.0	0.2	10.8	320.2	331.7	80.6	92.6	365.2	296.2	417.4	267.4	254.7	848.7	0.17	83.01	82.69	83.13	0.16	82.84	82.31	82.97
6.0	235.00	15.9	0.0	4.3	319.4	302.3	80.7	92.5	366.3	296.4	413.5	266.1	254.9	799.9	0.17	83.01	82.69	83.17	0.17	82.87	82.32	82.98
7.0	236.00	15.9	0.0	3.1	317.9	282.8	80.6	90.7	365.4	295.0	410.2	264.6	254.4	734.5	0.17	83.00	82.69	83.19	0.16	82.86	82.33	83.01
8.0	237.00	15.8	0.0	2.7	315.7	270.0	80.5	89.8	363.2	293.1	406.6	262.3	253.4	690.1	0.17	82.97	82.71	83.24	0.16	82.85	82.36	83.07
9.0	238.00	15.8	0.0	2.7	313.7	261.0	80.6	89.4	360.0	291.1	403.2	260.6	253.6	664.2	0.17	82.93	82.71	83.25	0.17	82.83	82.36	83.08
10.0	239.00	15.8	0.0	2.7	311.5	254.0	80.8	88.7	356.6	288.7	400.3	258.6	253.4	650.4	0.17	82.92	82.70	83.28	0.16	82.83	82.36	83.11
11.0	240.00	15.7	0.0	2.6	308.8	248.7	80.4	89.0	352.7	285.5	396.6	256.0	253.0	641.4	0.17	82.95	82.68	83.29	0.16	82.82	82.37	83.15
12.0	241.00	15.7	0.0	2.6	305.1	245.4	80.6	88.8	349.0	282.5	392.8	253.7	252.4	634.5	0.17	82.94	82.69	83.33	0.17	82.84	82.40	83.17
13.0	242.00	15.7	0.0	2.6	303.2	241.9	80.6	88.3	345.0	279.1	388.9	251.4	251.8	625.2	0.17	82.95	82.70	83.34	0.16	82.86	82.42	83.19
14.0	243.00	15.6	0.0	2.6	300.6	238.5	80.4	88.4	340.9	276.2	385.1	248.9	251.9	616.7	0.17	82.95	82.73	83.38	0.17	82.87	82.45	83.22
15.0	244.00	15.6	0.0	2.7	297.7	236.1	80.7	87.8	337.1	273.0	381.5	245.9	250.9	612.7	0.17	82.93	82.72	83.40	0.17	82.83	82.43	83.22
16.0	245.00	15.5	0.0	2.7	295.0	233.2	80.8	88.2	333.1	269.7	378.0	243.5	250.7	610.5	0.17	82.94	82.74	83.42	0.16	82.84	82.45	83.22
17.0	246.00	15.5	0.0	2.7	292.0	231.1	80.4	88.2	329.0	266.4	374.0	240.6	250.0	610.3	0.17	82.91	82.73	83.42	0.17	82.82	82.44	83.23
18.0	247.00	15.5	0.0	2.7	289.4	229.3	80.8	87.8	325.3	263.5	370.3	238.5	249.5	611.2	0.17	82.93	82.75	83.47	0.16	82.86	82.48	83.24
19.0	248.00	15.4	0.0	2.8	286.6	227.9	80.7	87.7	321.6	260.1	366.9	235.5	249.1	613.3	0.17	82.96	82.76	83.46	0.17	82.86	82.48	83.25
20.0	249.00	15.4	0.0	3.0	284.1	227.5	80.6	88.5	317.9	257.4	363.4	233.0	248.7	616.9	0.17	82.96	82.79	83.48	0.16	82.88	82.49	83.27
21.0	250.00	15.3	0.0	3.1	281.2	226.5	80.6	88.3	314.1	254.8	359.4	230.3	247.2	620.7	0.17	82.98	82.80	83.50	0.17	82.88	82.54	83.30
22.0	251.00	15.3	0.0	3.2	279.0	225.9	80.9	88.3	310.7	252.4	356.2	228.3	247.6	627.6	0.17	83.00	82.80	83.51	0.16	82.90	82.54	83.36
23.0	252.00	15.2	0.0	3.3	276.8	226.0	80.7	88.3	307.4	249.9	352.9	226.1	247.5	638.0	0.17	83.02	82.79	83.50	0.17	82.90	82.54	83.30
24.0	253.00	15.2	0.0	3.4	274.4	226.6	80.9	87.7	304.2	247.6	349.8	224.0	246.5	650.7	0.17	83.05	82.81	83.52	0.17	82.90	82.54	83.29
25.0	254.00	15.1	0.0	3.6	272.1	227.5	80.9	87.3	300.9	245.4	346.6	221.7	245.9	661.1	0.17	83.07	82.82	83.53	0.17	82.90	82.53	83.27
26.0	255.00	15.1	0.0	3.8	270.0	228.0	81.0	87.0	298.2	243.6	343.2	219.6	245.3	667.9	0.17	83.07	82.82	83.50	0.16	82.90	82.53	83.24
27.0	256.00	15.0	0.0	4.0	267.8	229.2	80.7	87.7	295.7	241.5	340.0	217.5	244.1	675.1	0.17	83.10	82.82	83.51	0.16	82.92	82.53	83.24
28.0	257.00	15.0	0.0	4.5	265.7	231.5	80.4	87.9	293.4	240.1	336.6	215.2	243.4	686.8	0.17	83.12	82.83	83.50	0.16	82.95	82.56	83.19
29.0	258.00	14.9	0.1	7.1	264.4	239.9	80.8	88.3	292.5	239.3	333.7	213.4	243.1	750.9	0.17	83.11	82.82	83.52	0.17	82.93	82.56	83.21
30.0	259.00	14.8	0.1	8.3	263.2	248.1	80.5	89.2	293.4	239.2	330.7	211.3	241.3	793.6	0.17	83.09	82.83	83.52	0.17	82.97	82.59	83.23
31.0	260.00	14.7	0.0	6.9	262.6	245.6	80.9	88.0	294.5	239.0	328.2	209.9	241.1	761.5	0.17	83.09	82.84	83.54	0.17	82.99	82.61	83.22
32.0	261.00	14.6	0.0	6.6	261.5	243.5	80.6	88.4	295.8	238.1	325.0	208.1	239.7	734.2	0.17	83.11	82.87	83.52	0.17	83.00	82.62	83.24
33.0	262.00	14.6	0.0	6.8	260.8	241.8	80.7	88.7	297.2	237.9	322.9	206.9	239.2	725.5	0.17	83.08	82.85	83.51	0.17	82.98	82.62	83.28
34.0	263.00	14.5	0.0	7.1	260.3	240.9	80.8	88.3	299.4	237.4	320.8	205.9	238.0	709.6	0.17	83.07	82.84	83.52	0.16	82.96	82.62	83.24
35.0	264.00	14.4	0.0	7.3	260.1	240.7	81.0	88.6	301.9	237.2	318.6	205.0	237.7	704.4	0.17	83.05	82.82	83.52	0.16	82.94	82.62	83.26
36.0	265.00	14.3	0.0	7.8	259.7	242.2	80.9	88.2	304.9	236.9	316.6	204.0	235.9	702.2	0.17	83.09	82.83	83.52	0.16	82.95	82.62	83.27
37.0	266.00	14.3	0.0	8.2	259.8	245.4	80.9	89.0	307.7	237.6	314.8	203.3	235.4	726.6	0.17	83.09	82.85	83.51	0.16	82.99	82.63	83.27
38.0	267.00	14.2	0.0	8.2	260.1	248.5	81.1	87.8	310.9	238.3	313.3	203.0	235.2	750.1	0.17	83.14	82.86	83.51	0.16	83.01	82.66	83.27
39.0	268.00	14.1	0.0	8.1	260.4	250.5	81.1	88.0	314.2	239.0	311.8	202.5	234.6	765.5	0.17	83.14	82.86	83.49	0.16	83.02	82.66	83.25
40.0	269.00	14.0	0.0	8.4	260.9	253.9	81.1	88.9	317.1	240.6	310.3	202.2	234.3	785.1	0.17	83.22	82.90	83.53	0.16	83.08	82.69	83.27
41.0	270.00	13.9	0.0	8.8	261.4	258.5	81.2	89.3	320.2	242.4	308.9	202.0	233.3	819.1	0.17	83.35	82.94	83.54	0.17	83.20	82.73	83.34
42.0	271.00	13.8	0.1	9.8	262.1	268.4	81.2	89.4	323.5	244.8	307.9	201.9	232.5	878.2	0.17	83.43	82.96	83.57	0.16	83.26	82.77	83.36
43.0	272.00	13.7	0.5	10.8	263.2	278.4	81.4	90.3	327.8	248.1	306.7	200.9	231.7	924.2	0.17	83.51	82.99	83.58	0.17	83.31	82.80	83.36
44.0	273.00	13.6	0.0	11.6	264.5	283.7	81.5	90.5	332.2	251.6	305.7	200.3	231.0	955.0	0.17	83.58	83.01	83.59	0.17	83.36	82.82	83.38
45.0	274.00	13.5	0.1	10.7	265.4	287.5	81.6	90.4	336.2	254.2	305.1	202.2	229.4	840.6	0.17	83.58	83.03	83.61	0.17	83.40	82.85	83.39
46.0	275.00	13.4	0.1	10.2	266.7	289.5	81.9	90.7	340.1	256.8	304.7	202.6	229.2	833.4	0.17	83.64	83.08	83.65	0.16	83.47	82.89	83.41
47.0	276.00	13.3	0.1	10.0	267.9	292.8	81.8	91.0	344.7	259.5	304.2	202.7	228.1	862.0	0.17	83.70	83.11	83.65	0.17	83.54	82.92	83.43
48.0	277.00	13.2	0.1	10.7	269.5	295.9	81.9	90.9	348.8	262.2	304.2	203.0	228.1	879.7	0.17	83.77	83.14	83.70	0.17	83.59	82.93	83.43
49.0	278.00	13.1	0.2	10.7	271.3	297.8	82.0	91.4	356.6	264.9	304.1	203.5	227.4	884.4	0.17	83.83	83.17	83.73	0.16	83.66	82.99	83.48
50.0	279.00	13.0	0.2	10.6	273.3	299.4	82.1	91.6	363.5	267.9	304.2	203.9	226.8	887.3	0.17	83.90	83.21	83.74	0.16	83.72	83.03	83.52
51.0	280.00	12.9	0.3	10.9	275.1	300.6	82.1	91.2	370.6	269.9	304.6	204.4	225.9	879.5	0.17	83.95	83.25	83.79	0.17	83.77	83.06	83.53
52.0	281.00	12.8	0.3	10.9	277.0	302.1	82.0	91.7	377.5	271.9	304.9	205.1	225.									

90.0	319.0	8.7	1.4	11.6	323.4	311.6	83.3	93.9	473.9	314.7	369.7	256.4	202.0	871.0	0.17	85.40	84.56	85.47	0.16	85.39	84.42	86.01
91.0	320.0	8.6	1.4	11.6	324.3	311.8	83.2	93.1	474.7	315.6	371.0	257.7	202.5	870.1	0.17	85.28	84.55	85.48	0.16	85.33	84.45	86.03
92.0	321.0	8.5	1.4	11.6	324.8	311.2	83.2	93.1	475.4	316.4	372.9	258.8	200.5	869.8	0.17	85.28	84.55	85.51	0.16	85.30	84.42	86.06
93.0	322.0	8.3	1.5	11.8	325.6	311.5	82.9	95.1	475.8	316.8	374.2	259.8	201.1	868.7	0.17	85.27	84.54	85.55	0.16	85.29	84.43	86.13
94.0	323.0	8.2	1.5	11.8	326.4	311.6	83.3	94.3	476.8	317.8	376.1	260.9	200.6	866.6	0.17	85.27	84.55	85.58	0.16	85.26	84.41	86.14
95.0	324.0	8.1	1.5	11.8	326.9	312.1	83.0	93.6	477.4	318.2	377.6	262.0	199.1	865.5	0.17	85.32	84.58	85.59	0.16	85.30	84.43	86.16
96.0	325.0	8.0	1.5	11.8	327.9	311.5	82.9	93.9	478.0	318.9	379.5	263.4	199.7	864.6	0.17	85.30	84.59	85.59	0.16	85.27	84.40	86.18
97.0	326.0	7.9	1.5	11.9	328.1	311.4	83.2	93.6	477.6	318.8	381.0	264.8	198.0	862.2	0.17	85.23	84.58	85.62	0.16	85.22	84.42	86.19
98.0	327.0	7.8	1.5	11.9	328.8	311.5	83.1	94.7	478.3	319.2	382.5	266.2	198.0	859.6	0.17	85.22	84.58	85.66	0.16	85.23	84.44	86.25
99.0	328.0	7.7	1.5	11.9	329.2	310.9	83.2	94.5	478.2	319.5	383.9	267.6	196.6	858.5	0.17	85.22	84.61	85.66	0.16	85.24	84.47	86.31
100.0	329.0	7.6	1.5	11.8	329.9	309.5	82.9	94.8	478.1	320.2	385.1	269.0	197.2	857.4	0.17	85.20	84.62	85.69	0.16	85.24	84.49	86.35
101.0	330.0	7.5	1.4	11.7	330.5	308.1	82.8	94.5	478.6	320.4	386.5	270.3	196.6	857.1	0.17	85.15	84.62	85.70	0.16	85.22	84.48	86.34
102.0	331.0	7.4	1.3	11.7	331.0	306.9	82.9	94.2	478.3	320.8	388.0	271.9	196.0	857.7	0.17	85.16	84.64	85.71	0.16	85.21	84.49	86.34
103.0	332.0	7.3	1.2	11.5	331.5	306.3	82.7	93.8	478.6	320.9	389.2	273.6	195.0	857.6	0.17	85.17	84.64	85.72	0.16	85.20	84.51	86.36
104.0	333.0	7.2	0.8	11.5	332.5	304.9	82.9	94.5	479.8	321.5	390.3	275.5	195.4	847.4	0.17	85.16	84.64	85.73	0.16	85.19	84.47	86.35
105.0	334.0	7.2	0.5	11.7	333.4	303.3	83.2	93.9	481.5	321.9	391.6	277.0	195.0	838.4	0.17	85.17	84.65	85.73	0.17	85.16	84.45	86.34
106.0	335.0	7.1	0.2	11.6	334.5	301.2	83.1	93.7	483.7	322.2	393.3	278.9	194.6	829.2	0.17	85.22	84.67	85.76	0.16	85.17	84.44	86.35
107.0	336.0	7.0	0.1	11.4	335.4	299.6	83.0	93.9	485.4	322.7	394.5	280.6	193.7	819.5	0.17	85.22	84.67	85.75	0.16	85.18	84.45	86.35
108.0	337.0	6.9	0.0	11.1	336.4	298.4	82.8	94.5	487.4	323.2	395.6	282.4	193.4	807.1	0.17	85.28	84.67	85.75	0.16	85.21	84.48	86.39
109.0	338.0	6.8	0.0	10.9	337.3	297.5	82.9	93.1	489.5	323.5	396.7	283.9	193.0	797.5	0.17	85.30	84.69	85.73	0.16	85.21	84.48	86.37
110.0	339.0	6.8	0.0	10.7	338.2	296.5	83.3	93.5	491.7	323.4	397.7	285.3	192.7	791.8	0.17	85.34	84.71	85.77	0.16	85.26	84.50	86.38
111.0	340.0	6.7	0.0	10.6	339.0	295.6	83.1	93.0	493.5	323.2	398.5	286.9	192.9	789.1	0.17	85.34	84.72	85.75	0.16	85.26	84.50	86.36
112.0	341.0	6.6	0.0	10.5	339.5	295.0	83.0	92.4	495.0	323.0	399.3	288.1	192.2	787.0	0.17	85.37	84.76	85.77	0.16	85.27	84.52	86.35
113.0	342.0	6.6	0.0	10.5	340.1	293.5	83.0	93.0	496.2	322.7	399.5	289.6	192.3	783.3	0.17	85.32	84.71	85.74	0.16	85.22	84.49	86.32
114.0	343.0	6.5	0.0	10.5	340.6	293.4	83.1	93.0	497.2	322.8	400.2	290.6	192.2	780.0	0.17	85.33	84.72	85.76	0.16	85.23	84.51	86.32
115.0	344.0	6.4	0.0	10.5	340.6	291.8	83.5	93.3	498.0	321.0	400.6	291.7	191.7	775.0	0.17	85.37	84.73	85.76	0.16	85.26	84.51	86.38
116.0	345.0	6.4	0.0	10.5	340.7	290.8	83.5	92.9	498.8	320.5	401.2	292.4	190.8	774.2	0.17	85.43	84.77	85.80	0.16	85.36	84.58	86.41
117.0	346.0	6.3	0.0	10.7	340.8	290.3	83.1	93.4	498.9	320.1	401.0	293.2	190.7	779.2	0.17	85.44	84.79	85.80	0.16	85.35	84.62	86.43
118.0	347.0	6.2	0.1	10.8	340.9	290.2	83.6	92.5	499.4	319.6	401.4	293.8	190.1	783.4	0.17	85.45	84.80	85.80	0.16	85.37	84.61	86.44
119.0	348.0	6.1	0.1	11.0	340.9	290.2	83.5	93.6	499.1	319.3	401.7	294.4	189.8	787.6	0.17	85.49	84.81	85.82	0.16	85.40	84.65	86.47
120.0	349.0	6.1	0.1	11.0	341.0	289.9	83.6	92.3	499.3	319.0	402.2	294.7	189.6	789.8	0.17	85.56	84.84	85.85	0.16	85.45	84.67	86.43
121.0	350.0	6.0	0.1	11.0	341.0	290.7	83.7	93.0	499.2	319.1	402.6	294.9	189.3	791.4	0.17	85.63	84.86	85.86	0.16	85.50	84.69	86.46
122.0	351.0	5.9	0.2	11.1	341.1	291.1	83.7	92.5	499.0	319.1	403.0	295.1	189.2	795.5	0.17	85.68	84.89	85.90	0.16	85.55	84.74	86.48
123.0	352.0	5.8	0.3	11.2	341.0	291.1	83.7	92.5	499.2	319.1	403.4	295.3	188.9	802.4	0.17	85.76	84.92	85.93	0.16	85.63	84.78	86.51
124.0	353.0	5.8	0.2	11.2	341.1	290.9	83.8	93.8	499.2	319.2	403.9	295.6	188.6	805.1	0.17	85.87	84.97	85.95	0.16	85.72	84.81	86.55
125.0	354.0	5.7	0.2	11.3	341.1	290.8	84.2	93.3	497.9	319.4	404.3	295.7	188.2	807.2	0.17	85.94	85.01	85.95	0.16	85.77	84.85	86.57
126.0	355.0	5.6	0.2	11.3	341.2	290.8	84.3	93.1	498.2	319.5	404.8	295.9	187.7	808.6	0.17	86.00	85.03	85.99	0.16	85.83	84.91	86.65
127.0	356.0	5.6	0.2	11.4	341.4	290.4	84.1	93.8	498.2	319.8	405.3	296.1	187.5	811.6	0.17	86.06	85.07	86.02	0.16	85.91	84.97	86.66
128.0	357.0	5.5	0.2	11.5	341.5	290.4	84.6	94.5	498.0	320.2	405.9	296.2	187.2	818.6	0.17	86.16	85.12	86.05	0.16	86.01	85.04	86.76
129.0	358.0	5.4	0.2	11.6	341.7	290.1	84.2	93.7	498.5	320.5	406.2	296.2	186.9	824.1	0.17	86.25	85.16	86.08	0.16	86.11	85.09	86.81
130.0	359.0	5.3	0.3	11.7	342.1	290.2	84.6	94.4	499.3	321.0	407.0	296.5	186.6	825.2	0.17	86.34	85.18	86.12	0.16	86.16	85.12	86.88
131.0	360.0	5.3	0.2	11.7	342.5	289.3	84.8	93.5	500.2	321.8	407.9	296.6	186.2	825.6	0.17	86.42	85.23	86.16	0.16	86.24	85.16	86.90
132.0	361.0	5.2	0.1	11.5	342.9	288.0	84.8	93.5	501.2	322.7	408.6	296.8	185.2	825.3	0.17	86.50	85.29	86.21	0.16	86.33	85.22	86.93
133.0	362.0	5.2	0.0	11.3	343.1	287.3	84.8	93.6	501.9	322.9	409.2	296.7	184.6	817.6	0.17	86.51	85.34	86.25	0.16	86.41	85.29	86.99
134.0	363.0	5.1	0.0	11.0	343.5	285.9	84.6	94.0	502.7	323.1	410.1	296.9	184.5	805.9	0.17	86.57	85.39	86.28	0.16	86.48	85.34	87.05
135.0	364.0	5.0	0.0	10.8	343.7	284.1	84.8	93.5	503.5	323.3	410.9	296.9	183.9	791.4	0.17	86.63	85.45	86.33	0.16	86.55	85.38	87.09
136.0	365.0	5.0	0.0	10.6	343.6	281.8	84.5	93.4	503.7	323.0	411.5	296.6	183.4	779.2	0.17	86.62	85.47	86.36	0.16	86.56	85.42	87.10
137.0	366.0	4.9	0.0	10.6	343.6	280.1	84.4	93.3	504.2	322.5	412.3	296.5	182.6	770.9	0.17	86.58	85.51	86.39	0.16	86.56	85.46	87.15
138.0	367.0	4.9	0.0	10.6	343.5	278.7	84.7	93.8	504.2	321.8	413.1	296.1	182.4	765.3	0.17	86.51	85.53	86.43	0.16	86.57	85.50	87.18
139.0	368.0	4.8	0.0	10.4	343.3	276.7	84.6	93.1	504.0	321.0	413.8	295.7	182.2	759.3	0.17	86.51	85.58	86.43	0.16	86.58	85.55	87.21
140.0	369.0	4.8	0.0	10.1	343.0	274.5	84.4	92.8	503.6	319.9	414.5	295.4	181.7	753.2	0.17	86.51	85.60	86.41	0.16	86.59	85.57	87.21
141.0	370.0	4.7	0.0	9.8	342.6	272.5	84.4	92.9	501.9	318.7	415.1	295.3	181.8	746.3	0.17	86.48	85.64	86.45	0.16	86.57	85.60	87.23
142.0	371.0	4.7	0.0	9.4	342.1	270.9	84.7	93.0	500.2	317.6	415.9	294.9	181.6	738.6	0.17	86.56	85.67	86.50	0.16	86.63	85.62	87.25
143.0	372.0	4.6	0.0	9.4	341.4	267.9	84.8	93.4	498.3	316.5	416.3	295.0	180.9	733.0	0.17	86.66	85.71	86.54	0.16	86.69	85.64	87.29
144.0	373.0	4.6	0.0	9.5	340.8	266.2	84.6	93.2	496.3</													

183.0	412.0	3,4	0,0	8,8	311,5	224,1	85,8	92,0	403,7	290,4	408,3	276,9	178,2	679,7	0,17	87,76	87,09	87,57	0,16	87,92	87,08	88,17
184.0	413.0	3,4	0,0	8,9	310,9	224,6	86,2	92,0	401,8	290,1	407,9	276,4	178,2	681,9	0,17	87,73	87,11	87,61	0,16	87,93	87,11	88,19
185.0	414.0	3,4	0,0	9,0	310,4	224,2	86,1	92,6	400,1	289,7	407,2	275,9	178,9	677,5	0,17	87,73	87,13	87,59	0,16	87,94	87,15	88,19
186.0	415.0	3,4	0,0	8,9	309,7	224,0	86,0	92,1	398,3	289,6	406,7	275,3	178,7	670,8	0,17	87,74	87,13	87,59	0,16	87,91	87,15	88,19
187.0	416.0	3,3	0,0	8,9	309,1	223,4	86,5	91,8	396,3	289,0	406,2	274,9	179,1	668,7	0,17	87,72	87,14	87,58	0,16	87,90	87,16	88,18
188.0	417.0	3,3	0,0	8,9	308,5	223,8	86,6	91,9	394,8	288,6	405,8	274,3	179,2	674,9	0,17	87,74	87,15	87,58	0,16	87,91	87,18	88,18
189.0	418.0	3,3	0,0	8,9	308,0	223,6	86,5	92,0	392,9	288,2	405,4	273,8	179,4	676,6	0,17	87,77	87,17	87,58	0,16	87,93	87,20	88,15
190.0	419.0	3,3	0,0	8,9	307,5	223,7	86,7	92,3	391,3	288,0	405,1	273,5	179,7	680,0	0,17	87,82	87,22	87,60	0,16	87,97	87,22	88,20
191.0	420.0	3,3	0,0	8,9	307,0	224,0	86,8	92,2	389,7	287,6	404,8	272,9	180,1	683,8	0,17	87,85	87,24	87,61	0,16	87,99	87,23	88,22
192.0	421.0	3,2	0,0	9,0	306,4	223,8	86,7	92,7	388,1	287,0	404,4	272,4	180,3	687,6	0,17	87,86	87,26	87,62	0,16	88,00	87,26	88,23
193.0	422.0	3,2	0,0	9,0	305,9	223,4	86,6	92,2	386,7	286,8	404,2	271,9	179,7	691,0	0,17	87,86	87,26	87,62	0,16	88,00	87,29	88,24
194.0	423.0	3,2	0,0	8,9	305,1	223,6	86,3	92,2	385,0	286,7	403,6	271,1	179,3	687,9	0,17	87,87	87,30	87,60	0,16	88,02	87,32	88,23
195.0	424.0	3,2	0,0	9,0	304,5	223,7	85,9	91,6	383,5	286,4	403,3	270,4	178,7	689,0	0,17	87,88	87,33	87,61	0,16	88,04	87,32	88,19
196.0	425.0	3,1	0,0	8,9	304,1	223,9	86,2	91,5	381,9	285,9	403,0	269,7	179,8	692,0	0,17	87,81	87,31	87,62	0,16	88,00	87,32	88,19
197.0	426.0	3,1	0,0	8,9	303,6	224,3	86,2	91,9	380,6	285,5	402,7	269,2	180,1	695,1	0,17	87,75	87,32	87,61	0,16	87,96	87,33	88,18
198.0	427.0	3,1	0,0	8,9	303,2	223,9	86,0	92,0	379,6	285,0	402,5	268,7	180,1	692,5	0,17	87,70	87,34	87,62	0,16	87,94	87,34	88,17
199.0	428.0	3,1	0,0	8,9	302,9	223,5	86,2	92,1	378,4	284,9	402,0	268,4	180,6	691,1	0,17	87,70	87,35	87,61	0,16	87,94	87,35	88,21
200.0	429.0	3,1	0,0	8,9	302,4	224,0	86,3	92,7	377,3	284,6	401,6	268,1	180,6	692,1	0,17	87,70	87,34	87,61	0,16	87,95	87,35	88,19
201.0	430.0	3,0	0,0	8,9	301,8	223,7	86,0	91,6	376,1	284,6	400,9	267,5	180,0	690,6	0,17	87,71	87,37	87,60	0,16	87,95	87,39	88,21
202.0	431.0	3,0	0,0	8,9	301,3	223,7	86,0	91,8	375,1	284,1	400,7	266,9	179,9	688,8	0,17	87,68	87,36	87,61	0,16	87,91	87,38	88,17
203.0	432.0	3,0	0,0	8,9	301,0	223,2	86,4	91,9	373,9	283,6	400,4	266,4	179,5	688,4	0,17	87,69	87,36	87,62	0,16	87,91	87,39	88,16
204.0	433.0	3,0	0,0	8,9	300,6	223,3	86,3	91,8	372,5	283,3	400,2	265,9	181,1	692,5	0,17	87,66	87,38	87,59	0,16	87,89	87,39	88,17
205.0	434.0	3,0	0,0	8,9	300,2	223,4	86,4	92,2	371,8	282,8	399,8	265,4	181,0	695,2	0,17	87,69	87,39	87,62	0,16	87,92	87,41	88,17
206.0	435.0	3,0	0,0	8,9	299,8	223,2	86,4	92,3	370,8	282,4	399,5	264,9	181,4	697,7	0,17	87,72	87,41	87,60	0,16	87,90	87,40	88,16
207.0	436.0	2,9	0,0	8,9	299,4	223,1	86,3	92,4	370,0	281,9	399,0	264,6	181,4	701,0	0,17	87,72	87,42	87,60	0,16	87,90	87,41	88,16
208.0	437.0	2,9	0,0	8,9	299,0	223,2	86,4	91,9	368,5	281,8	399,0	264,2	181,6	699,7	0,17	87,72	87,43	87,60	0,16	87,91	87,46	88,17
209.0	438.0	2,9	0,1	8,9	298,6	223,6	86,4	91,9	367,5	281,4	398,5	263,9	181,8	698,1	0,17	87,69	87,43	87,59	0,16	87,90	87,45	88,18
210.0	439.0	2,9	0,0	8,9	298,1	223,3	86,6	92,3	366,5	280,9	398,2	263,6	181,3	698,8	0,17	87,69	87,44	87,60	0,16	87,90	87,49	88,20
211.0	440.0	2,9	0,0	8,9	297,7	223,0	86,6	92,4	365,9	280,3	397,7	263,3	181,3	697,7	0,17	87,67	87,46	87,59	0,16	87,90	87,50	88,20
212.0	441.0	2,8	0,1	8,9	297,3	222,5	86,5	92,0	364,9	279,9	397,2	263,0	181,6	700,3	0,17	87,64	87,45	87,57	0,16	87,87	87,51	88,17
213.0	442.0	2,8	0,1	8,9	297,0	223,5	86,8	92,2	364,1	279,7	396,8	262,9	181,8	702,6	0,17	87,70	87,48	87,56	0,16	87,90	87,54	88,19
214.0	443.0	2,8	0,1	8,9	296,5	223,8	86,7	92,8	362,8	279,2	396,4	262,5	181,6	707,7	0,17	87,77	87,50	87,57	0,16	87,96	87,56	88,24
215.0	444.0	2,8	0,1	8,9	296,1	223,8	86,7	92,6	361,9	278,9	396,0	261,9	181,7	708,7	0,17	87,84	87,51	87,58	0,16	88,00	87,58	88,25
216.0	445.0	2,8	0,1	8,9	295,7	224,4	86,7	92,8	360,7	278,9	395,7	261,7	181,6	712,2	0,17	87,88	87,52	87,60	0,16	88,03	87,58	88,26
217.0	446.0	2,7	0,1	8,9	295,5	224,8	86,6	92,6	360,1	278,7	395,3	261,4	182,0	716,8	0,17	87,93	87,54	87,61	0,16	88,05	87,62	88,29
218.0	447.0	2,7	0,1	8,9	295,1	224,9	86,9	92,5	359,2	278,2	395,0	261,1	182,2	717,8	0,17	87,95	87,56	87,63	0,16	88,07	87,62	88,31
219.0	448.0	2,7	0,1	8,8	295,0	225,1	87,0	92,4	358,5	278,0	394,7	261,0	182,6	719,0	0,17	88,00	87,58	87,64	0,16	88,12	87,65	88,32
220.0	449.0	2,7	0,1	8,9	294,6	225,4	87,0	92,9	357,7	277,7	394,2	260,8	182,4	718,8	0,17	88,04	87,61	87,67	0,16	88,16	87,68	88,30
221.0	450.0	2,7	0,1	8,8	294,3	225,1	87,2	92,5	356,6	277,4	394,0	260,7	182,7	715,8	0,17	88,08	87,62	87,67	0,16	88,18	87,70	88,34
222.0	451.0	2,6	0,1	8,8	293,9	224,7	86,7	92,7	355,9	277,2	393,7	260,3	182,2	713,3	0,17	88,12	87,65	87,69	0,16	88,22	87,74	88,41
223.0	452.0	2,6	0,1	8,8	293,3	225,3	86,8	92,6	355,2	277,1	393,1	260,0	182,3	711,3	0,17	88,13	87,68	87,74	0,16	88,24	87,78	88,39
224.0	453.0	2,6	0,1	8,8	293,3	224,9	86,7	92,8	354,2	277,0	392,9	259,7	182,6	708,8	0,17	88,12	87,70	87,73	0,16	88,25	87,79	88,39
225.0	454.0	2,6	0,1	8,8	292,9	224,9	86,8	92,5	353,6	276,7	392,6	259,2	182,5	708,7	0,17	88,05	87,69	87,74	0,16	88,22	87,80	88,40
226.0	455.0	2,6	0,1	8,8	292,9	224,4	86,8	93,1	353,2	276,6	392,4	259,2	183,3	706,5	0,17	88,09	87,73	87,77	0,16	88,23	87,80	88,43
227.0	456.0	2,6	0,1	8,7	292,6	224,3	86,9	92,7	352,6	276,3	391,9	259,2	183,0	706,7	0,17	88,11	87,74	87,79	0,16	88,24	87,82	88,43
228.0	457.0	2,5	0,1	8,7	292,4	223,9	87,0	92,8	352,3	276,2	391,3	259,2	183,2	707,6	0,17	88,09	87,74	87,79	0,16	88,23	87,84	88,43
229.0	458.0	2,5	0,1	8,7	292,2	223,8	87,1	92,7	351,8	276,1	390,7	258,9	183,4	708,5	0,17	88,10	87,75	87,81	0,16	88,25	87,84	88,47
230.0	459.0	2,5	0,1	8,6	291,9	224,0	86,8	92,8	351,2	275,6	390,7	258,9	183,3	708,7	0,17	88,13	87,76	87,83	0,16	88,27	87,87	88,46
231.0	460.0	2,5	0,1	8,5	291,7	224,0	87,0	92,5	350,8	275,4	390,2	258,6	183,4	705,4	0,17	88,18	87,79	87,83	0,16	88,29	87,86	88,47
232.0	461.0	2,5	0,1	8,4	291,5	223,4	87,0	92,7	350,3	275,2	389,9	258,5	183,5	700,9	0,17	88,24	87,80	87,86	0,16	88,33	87,88	88,48
233.0	462.0	2,4	0,1	8,5	291,3	223,1	87,3	93,0	350,1	274,9	389,5	258,3	183,7	699,2	0,17	88,26	87,82	87,88	0,16	88,34	87,89	88,51
234.0	463.0	2,4	0,1	8,4	291,1	222,6	87,4	93,2	349,6	274,7	389,1	258,5	183,4	698,5	0,17	88,33	87,85	87,90	0,16	88,39	87,91	88,53
235.0	464.0	2,4	0,1	8,3	290,8	222,3	87,4	92,8	349,2	274,2	388,8	258,2	183,5	703,6	0,17	88,33	87,86	87,88	0,16	88,40	87,92	88,52
236.0	465.0	2,4	0,1	8,4	290,5	223,1	87,2	92,5	348,5	274,1	388,5	257,8	183,6	709,7	0,17	88,38	87,88	87,92	0,16	88,45	87,94	88,55
237.0	466.0	2,4	0,1	8,2	290,3	222,2	87,4	93,2	347,7	273,9	388,2	257,9	183,7									

276.0	505.0	1,7	0,1	8,1	276,8	219,5	87,5	92,9	324,8	256,6	365,6	253,1	183,9	693,7	0,17	89,05	88,88	88,75	0,16	89,31	88,90	89,40
277.0	506.0	1,7	0,1	8,1	276,7	219,0	87,5	93,3	324,6	256,0	365,2	253,2	184,3	692,6	0,17	89,03	88,87	88,79	0,16	89,30	88,91	89,38
278.0	507.0	1,7	0,1	8,1	276,6	218,9	87,4	93,3	324,5	255,8	364,8	253,1	184,6	692,7	0,17	89,00	88,87	88,73	0,16	89,25	88,91	89,36
279.0	508.0	1,7	0,1	8,1	276,3	219,3	87,4	93,0	324,2	255,5	364,3	252,9	184,6	694,6	0,17	89,03	88,88	88,77	0,16	89,27	88,93	89,36
280.0	509.0	1,7	0,1	8,1	276,2	218,9	87,4	93,2	324,2	255,2	363,8	253,0	184,7	695,3	0,17	89,05	88,90	88,77	0,16	89,29	88,93	89,37
281.0	510.0	1,7	0,1	8,1	275,9	219,0	87,1	93,0	324,2	254,9	363,3	252,7	184,6	695,6	0,17	88,99	88,88	88,77	0,16	89,27	88,93	89,36
282.0	511.0	1,6	0,1	8,1	275,8	219,1	87,4	93,2	324,2	254,6	363,0	252,8	184,5	694,6	0,17	88,96	88,88	88,74	0,16	89,23	88,95	89,35
283.0	512.0	1,6	0,1	8,1	275,6	219,0	87,3	92,8	324,1	254,4	362,6	252,7	184,0	695,8	0,17	88,93	88,89	88,73	0,16	89,21	88,95	89,31
284.0	513.0	1,6	0,1	8,1	275,5	219,1	87,4	92,7	324,0	254,1	362,0	252,8	184,6	696,7	0,17	88,90	88,91	88,75	0,16	89,21	88,96	89,31
285.0	514.0	1,6	0,1	8,0	275,3	218,9	87,2	92,9	323,7	253,9	361,6	252,9	184,4	697,8	0,17	88,87	88,91	88,72	0,16	89,18	88,96	89,28
286.0	515.0	1,6	0,1	8,0	275,0	219,1	86,8	93,0	323,5	253,3	361,2	252,6	184,5	697,6	0,17	88,86	88,92	88,73	0,16	89,16	88,97	89,28
287.0	516.0	1,6	0,1	7,9	274,9	219,5	87,2	93,0	323,3	253,1	360,8	252,4	184,7	697,4	0,17	88,85	88,92	88,73	0,16	89,15	88,97	89,29
288.0	517.0	1,5	0,1	7,9	274,7	219,1	87,2	92,7	322,9	252,7	360,3	252,7	184,8	697,0	0,17	88,81	88,92	88,70	0,16	89,11	88,96	89,29
289.0	518.0	1,5	0,1	7,9	274,4	218,7	86,9	92,8	322,7	252,8	360,0	252,5	184,2	697,3	0,17	88,78	88,91	88,68	0,16	89,07	88,97	89,25
290.0	519.0	1,5	0,1	7,9	274,2	219,2	87,1	92,8	322,2	252,4	359,6	252,3	184,6	697,3	0,17	88,77	88,92	88,69	0,16	89,07	88,97	89,26
291.0	520.0	1,5	0,1	7,9	274,0	219,4	87,0	92,7	322,1	251,9	359,3	252,2	184,6	696,7	0,17	88,76	88,90	88,71	0,16	89,03	88,95	89,24
292.0	521.0	1,5	0,1	8,0	273,9	218,9	87,1	92,6	321,8	251,7	358,9	252,0	185,0	696,1	0,17	88,74	88,91	88,71	0,16	89,01	88,96	89,22
293.0	522.0	1,5	0,1	8,0	273,7	219,0	87,1	92,5	321,8	251,4	358,5	252,0	184,8	694,7	0,17	88,73	88,91	88,70	0,16	89,01	88,95	89,20
294.0	523.0	1,4	0,1	8,0	273,6	218,9	87,0	92,3	321,5	251,3	358,0	252,0	185,2	694,0	0,17	88,71	88,91	88,69	0,16	89,00	88,95	89,20
295.0	524.0	1,4	0,1	8,0	273,4	219,0	86,7	92,4	321,1	251,0	357,6	252,1	185,5	694,3	0,17	88,72	88,93	88,68	0,16	89,00	88,96	89,18
296.0	525.0	1,4	0,1	7,9	273,1	219,0	87,0	92,3	320,8	250,9	357,2	251,9	184,6	696,1	0,17	88,67	88,92	88,65	0,16	88,96	88,95	89,15
297.0	526.0	1,4	0,1	7,9	272,9	218,8	86,8	92,5	320,3	250,4	356,8	251,7	185,3	696,2	0,17	88,67	88,94	88,64	0,16	88,95	88,96	89,11
298.0	527.0	1,4	0,1	7,9	272,8	218,9	86,8	92,5	320,2	250,5	356,4	251,7	185,3	696,0	0,17	88,63	88,92	88,63	0,16	88,93	88,94	89,10
299.0	528.0	1,4	0,1	8,0	272,6	218,5	86,7	92,5	319,8	250,1	356,0	251,6	185,4	696,4	0,17	88,60	88,92	88,62	0,16	88,91	88,93	89,08
300.0	529.0	1,3	0,1	8,0	272,4	218,7	87,1	92,6	319,6	249,8	355,7	251,6	185,4	697,2	0,17	88,60	88,93	88,61	0,16	88,90	88,95	89,09
301.0	530.0	1,3	0,1	8,0	272,3	218,6	86,9	92,5	319,2	249,8	355,4	251,7	185,5	696,5	0,17	88,61	88,92	88,60	0,16	88,91	88,93	89,08
302.0	531.0	1,3	0,1	8,0	272,1	218,8	86,9	92,3	319,1	249,5	355,3	251,4	185,4	697,1	0,17	88,62	88,92	88,58	0,16	88,91	88,94	89,05
303.0	532.0	1,3	0,1	8,0	271,8	218,7	86,8	92,2	318,9	249,2	354,6	251,2	185,1	697,1	0,17	88,62	88,94	88,60	0,16	88,90	88,95	89,04
304.0	533.0	1,3	0,1	7,9	271,8	218,3	86,6	92,1	318,7	249,1	354,3	251,1	185,9	696,1	0,17	88,57	88,91	88,57	0,16	88,87	88,92	89,00
305.0	534.0	1,3	0,1	7,9	271,4	218,6	86,5	91,9	318,4	248,9	353,9	250,8	185,2	696,1	0,17	88,58	88,92	88,58	0,16	88,88	88,93	88,98
306.0	535.0	1,2	0,1	7,9	271,5	218,6	86,9	92,3	318,3	248,6	353,6	250,9	186,0	695,6	0,17	88,55	88,94	88,56	0,16	88,86	88,91	88,98
307.0	536.0	1,2	0,1	7,9	271,5	218,0	87,0	93,0	318,2	248,4	353,7	250,9	186,3	694,1	0,17	88,55	88,94	88,56	0,16	88,85	88,94	88,99
308.0	537.0	1,2	0,1	7,9	271,5	217,3	87,4	92,5	318,3	248,1	353,5	250,7	186,9	693,4	0,17	88,55	88,94	88,56	0,16	88,86	88,94	88,97
309.0	538.0	1,2	0,1	7,9	271,4	217,1	87,4	92,9	318,1	248,0	353,2	250,6	187,1	693,2	0,17	88,58	88,94	88,54	0,16	88,86	88,96	88,99
310.0	539.0	1,2	0,1	7,7	271,2	216,4	87,5	92,8	317,9	247,8	352,8	250,4	187,2	693,1	0,17	88,64	88,91	88,53	0,16	88,86	88,94	89,02
311.0	540.0	1,2	0,1	7,4	271,1	216,6	87,5	92,7	317,8	247,5	352,6	250,2	187,4	693,6	0,17	88,65	88,93	88,53	0,16	88,89	88,97	89,02
312.0	541.0	1,1	0,1	7,3	270,8	216,8	87,4	92,6	317,4	247,4	352,2	249,9	187,0	693,5	0,17	88,69	88,95	88,53	0,16	88,94	88,97	89,00
313.0	542.0	1,1	0,1	7,3	270,5	217,1	86,8	92,6	317,1	247,2	351,9	249,5	187,0	693,3	0,17	88,70	88,94	88,51	0,16	88,92	88,97	89,00
314.0	543.0	1,1	0,1	7,2	270,4	217,2	87,2	92,6	316,7	246,9	351,6	249,4	187,2	699,0	0,17	88,70	88,96	88,55	0,16	88,95	88,97	89,01
315.0	544.0	1,1	0,1	7,2	270,2	217,5	87,3	92,8	316,2	246,6	351,4	249,3	187,6	699,5	0,17	88,69	88,95	88,54	0,16	88,92	88,97	89,00
316.0	545.0	1,1	0,1	7,2	269,9	217,5	87,4	93,2	315,8	246,6	350,8	248,9	187,5	699,8	0,17	88,65	88,94	88,56	0,16	88,90	88,94	89,03
317.0	546.0	1,1	0,1	7,1	269,7	217,1	87,5	93,0	315,4	245,9	350,4	248,8	187,7	699,5	0,17	88,69	88,95	88,54	0,16	88,92	88,98	89,02
318.0	547.0	1,1	0,1	7,1	269,5	217,1	87,7	93,6	314,9	245,8	350,1	248,7	187,8	699,4	0,17	88,72	88,96	88,53	0,16	88,95	88,98	89,05
319.0	548.0	1,1	0,1	7,2	269,3	217,2	87,7	93,0	314,4	245,5	349,8	248,2	188,5	700,1	0,17	88,78	88,97	88,56	0,16	88,98	89,02	89,09
320.0	549.0	1,0	0,1	7,0	269,0	217,1	87,0	93,0	314,0	244,9	349,6	247,7	188,7	700,2	0,17	88,81	88,98	88,56	0,16	89,01	89,03	89,10
321.0	550.0	1,0	0,1	7,0	268,2	217,2	87,2	92,4	313,2	244,6	349,3	247,4	186,7	700,2	0,17	88,83	89,01	88,59	0,16	89,06	89,04	89,08
322.0	551.0	1,0	0,1	6,8	268,0	217,4	87,2	92,2	312,7	244,1	348,8	246,7	187,6	699,3	0,17	88,84	89,03	88,57	0,16	89,06	89,03	89,09
323.0	552.0	1,0	0,1	6,8	267,9	217,5	87,2	92,2	312,2	243,7	348,6	246,6	188,4	698,3	0,17	88,83	89,03	88,58	0,16	89,04	89,07	89,09
324.0	553.0	1,0	0,1	6,7	267,7	217,4	87,2	92,3	311,5	243,7	348,5	246,2	188,4	697,4	0,17	88,82	89,03	88,62	0,16	89,02	88,99	89,09
325.0	554.0	1,0	0,1	6,7	267,4	217,3	87,3	92,2	311,0	243,4	348,3	245,8	188,4	697,1	0,17	88,80	89,03	88,63	0,16	89,01	88,98	89,11
326.0	555.0	1,0	0,1	6,6	266,8	216,9	87,4	92,7	310,2	242,9	347,8	245,0	188,1	696,7	0,17	88,78	89,05	88,61	0,16	89,01	89,00	89,13
327.0	556.0	1,0	0,1	6,6	266,4	216,5	87,4	92,6	309,4	242,5	347,3	244,5	188,1	699,2	0,17	88,81	89,06	88,63	0,16	89,03	89,01	89,16
328.0	557.0	0,9	0,1	6,5	266,1	216,9	87,5	92,6	309,0	242,1	346,9	244,2	188,3	700,5	0,17	88,82	89,05	88,65	0,16	89,04	89,00	89,16
329.0	558.0	0,9	0,1	6,5	265,8	216,5	87,7	92,3	308,4	241,7	346,7	243,4	188,7	699,0	0,17	88,84	89,06	88,65	0,16	89,03	89,00	89,17
330.0	559.0	0,9	0,1	6,5	265,5	216,4	87,8	92,8	307,8	241,3	346,2	243,1	188,9									

369,0	598,0	0,4	0,1	6,6	252,7	215,7	87,7	93,1	291,0	230,4	329,9	225,1	186,9	706,4	0,17	89,21	89,36	89,24	0,17	89,42	89,32	89,71
370,0	599,0	0,4	0,1	6,5	252,3	215,6	88,0	93,0	290,8	230,2	329,4	224,7	186,5	704,9	0,17	89,22	89,36	89,23	0,17	89,42	89,33	89,71
371,0	600,0	0,4	0,1	6,5	252,1	215,4	87,9	93,2	290,6	230,1	329,2	224,2	186,6	703,3	0,17	89,20	89,35	89,22	0,17	89,41	89,32	89,71
372,0	601,0	0,4	0,1	6,5	252,0	215,3	88,0	93,0	290,6	229,9	328,9	224,0	186,4	702,0	0,17	89,17	89,35	89,22	0,17	89,40	89,34	89,71
373,0	602,0	0,4	0,1	6,5	251,6	215,4	87,8	93,2	290,3	229,6	328,6	223,4	186,2	701,6	0,17	89,18	89,36	89,24	0,17	89,40	89,33	89,69
374,0	603,0	0,3	0,1	6,4	251,4	215,1	88,0	93,1	290,0	229,4	328,3	223,2	186,1	701,3	0,17	89,14	89,36	89,22	0,17	89,39	89,34	89,71
375,0	604,0	0,3	0,1	6,4	251,3	214,9	88,1	93,2	289,7	229,5	328,0	222,9	186,3	700,9	0,17	89,13	89,36	89,19	0,17	89,38	89,35	89,71
376,0	605,0	0,3	0,1	6,3	251,0	215,1	87,8	93,1	289,4	229,2	327,7	222,6	186,1	700,3	0,17	89,12	89,36	89,19	0,17	89,36	89,35	89,72
377,0	606,0	0,3	0,1	6,3	250,8	215,4	88,1	93,1	289,1	229,0	327,4	222,3	186,1	700,3	0,17	89,12	89,37	89,20	0,17	89,36	89,36	89,71
378,0	607,0	0,3	0,1	6,4	250,5	215,3	87,8	93,0	288,9	228,8	327,3	221,9	185,7	701,4	0,17	89,10	89,36	89,22	0,17	89,35	89,36	89,72
379,0	608,0	0,3	0,1	6,4	250,3	215,4	87,9	93,2	288,7	228,5	326,9	221,7	185,7	702,0	0,17	89,11	89,34	89,22	0,17	89,37	89,34	89,70
380,0	609,0	0,3	0,1	6,3	249,9	215,7	88,0	93,2	288,2	228,3	326,7	221,2	185,2	701,8	0,17	89,12	89,35	89,21	0,17	89,36	89,35	89,70
381,0	610,0	0,2	0,1	6,4	249,6	215,4	88,1	93,0	288,0	227,9	326,4	220,7	185,1	701,8	0,17	89,13	89,39	89,24	0,17	89,38	89,34	89,70
382,0	611,0	0,2	0,1	6,3	249,4	215,2	87,6	93,1	287,7	227,9	326,2	220,3	185,0	701,7	0,17	89,12	89,36	89,23	0,17	89,36	89,36	89,70
383,0	612,0	0,2	0,1	6,4	249,1	215,4	87,6	93,0	287,4	227,6	325,9	219,7	184,8	701,7	0,17	89,08	89,36	89,22	0,17	89,35	89,36	89,71
384,0	613,0	0,2	0,1	6,4	248,9	215,1	88,0	93,2	287,2	227,4	325,7	219,5	184,6	701,6	0,17	89,09	89,36	89,23	0,17	89,33	89,36	89,69
385,0	614,0	0,2	0,1	6,3	248,7	215,4	87,8	92,8	286,9	227,1	325,5	219,2	184,7	701,3	0,17	89,05	89,36	89,21	0,17	89,32	89,35	89,70
386,0	615,0	0,2	0,1	6,3	248,5	215,4	87,9	93,0	286,7	226,9	325,1	219,1	184,7	701,0	0,17	89,03	89,34	89,19	0,17	89,30	89,34	89,69
387,0	616,0	0,2	0,1	6,3	248,2	215,4	87,8	93,0	286,5	226,6	324,8	218,7	184,7	700,7	0,17	89,04	89,36	89,22	0,17	89,29	89,34	89,67
388,0	617,0	0,2	0,1	6,3	247,9	215,2	87,9	92,9	286,1	226,2	324,5	218,4	184,4	700,4	0,17	89,04	89,34	89,17	0,17	89,28	89,35	89,66
389,0	618,0	0,2	0,1	6,3	247,6	214,7	87,9	92,9	285,7	225,9	324,1	217,9	184,4	698,7	0,17	89,05	89,34	89,18	0,17	89,29	89,34	89,66
390,0	619,0	0,1	0,1	6,3	247,4	215,3	87,7	92,9	285,4	225,7	323,8	217,6	184,4	698,5	0,17	89,05	89,34	89,18	0,17	89,30	89,35	89,66
391,0	620,0	0,1	0,1	6,3	247,0	215,1	87,9	92,9	285,3	225,3	323,5	217,2	183,9	697,7	0,17	89,05	89,33	89,16	0,17	89,29	89,33	89,66
392,0	621,0	0,1	0,1	6,2	246,7	215,3	87,8	92,8	284,7	224,8	323,2	216,9	184,0	696,2	0,17	89,02	89,33	89,19	0,17	89,28	89,34	89,65
393,0	622,0	0,1	0,1	6,2	246,4	214,8	87,6	92,8	284,4	224,3	323,0	216,4	183,8	695,1	0,17	89,01	89,33	89,16	0,17	89,26	89,34	89,63
394,0	623,0	0,1	0,1	6,3	246,1	214,6	87,6	92,8	284,1	224,0	322,5	216,2	183,9	696,7	0,17	89,00	89,31	89,13	0,17	89,25	89,33	89,62
395,0	624,0	0,1	0,1	6,3	245,8	214,8	87,7	92,9	283,8	223,7	322,4	215,9	183,3	700,5	0,17	88,99	89,31	89,12	0,17	89,26	89,32	89,64
396,0	625,0	0,1	0,1	6,3	245,6	214,8	87,7	92,9	283,5	223,4	322,2	215,6	183,5	703,1	0,17	88,99	89,33	89,13	0,17	89,25	89,34	89,61
397,0	626,0	0,0	0,1	6,2	245,4	215,0	87,5	92,7	283,3	223,1	321,9	215,3	183,4	703,7	0,17	88,96	89,31	89,11	0,17	89,24	89,34	89,62

Manufacturer: HEARTHSTONE
 Model: MANCHESTER

Run: 2
 Project #: P-20174
 Test Duration: 397 min

	HHV	LHV
Eff	79,44%	85,86%
Comb Eff	97,49%	97,49%
HT Eff	81,49%	88,07%
Output	14 876	kJ/h
Burn Rate	0,95	kg/h
Grams CO	245	g
Input	18 726	kJ/h
MC wet	16,42	

Note: In the "Input data", "Calc. % O₂", "Fuel Properties", and "Mass Balance" columns, [e], [d], [g], [a], [b], [c], [h], [u], [w], [j], and [k] refer to their respective variables in Clauses 13.7.3

Ultimate CO₂
 CO_{2-ut} 19,64
 F_o
 1,061

	Air Fuel Ratio (A/F)
Overall Heating Efficiency:	79,44%
Combustion Efficiency:	97,49%
Heat Transfer Efficiency:	81,49%

Dry Molecular Weight (M _d)	29,82
Dry Moles Exhaust Gas (N _g):	446,94
Air Fuel Ratio (A/F)	12,82

Heat Output:	14 111 Btu/h	14 876 kJ/h
Heat Input:	17 763 Btu/h	18 726 kJ/h
Burn Duration:	6,62 h	
Burn Rate:	2,08 lb/h	0,945 kg/h
Stack Temp:	246,3 Deg. F	119,1 Deg. C

PRE-TEST SCALE AUDIT

Date: 2018-07-31 Manufacturer: Healthstone Model: Manchester
 Project #: PT 20174 Run: 2 Tech: MM Reviewer: SP

Scale Type	Audit		Measured Weight
	Equipment #	Weight	
Platform	EM-090	4.4 lbs, Class F	4.4 lbs
Wood	EM-090	4.4 lbs, Class F	4.4 lbs
Analytical	EM-128	100 mg, Class S	100 mg
Analytical	EM-128	200 g, Class S	200 g

LIMITS OF WEIGHT RANGES

ANALYTICAL SCALE: 50%-150% of dry filter weight, ± 0.1 mg
PLATFORM SCALE: 20% 80% of ideal test load weight, ± 0.1 lbs or 1%
WOOD SCALE: 20%-80% of ideal test load weight, ± 0.01 lbs or 1%

Date: 2-18-07-31 Manufacturer: Hearthstone Model: manchester
 Project #: PT 20174 Run: 2 Tech: MM Reviewer: BO

FOR TUNNELS < 12 in

 Barometric pressure (P_{bar}) 101.4 (KPa.) Static pressure (P_q) 0.20 (inches w.c.)
 Inside diameter: Port A _____ Port B _____
 Tunnel cross sectional area: .1963Ft²
 Pitot tube type: Standard

Traverse Point	Position (inches)			Velocity Head Δ_p (inches H ₂ O)	Tunnel Temperature (°F)
	6 po	7 po	8 po		
A - Centroid	3.00	3.50	4	0.58	75.70
B - Centroid	3.00	3.50	4	0.57	75.75
A-1	0.40	0.50	0.50	0.48	75.70
A-2	1.50	1.75	2	0.51	75.71
A-3	4.50	5.25	6	0.69	75.70
A-4	5.60	6.5	7.5	0.47	75.72
B-1	0.40	0.50	0.50	0.47	75.70
B-2	1.50	1.75	2	0.66	75.57
B-3	4.50	5.25	6	0.50	75.58
B-4	5.60	6.5	7.5	0.48	75.51
AVERAGE					

$$v_s = K_p C_p (\sqrt{\Delta p})_{avg} \sqrt{\frac{(T_s)_{avg}}{P_s M_s}}$$

Where,

 C_p = pitot tube coefficient, dimension less = 0.99 for standard pitot.

 Δ_p = manometer reading (inches H₂O)

 T_s = average absolute dilution tunnel temperature (°F + 460)

 P_s = absolute dilution tunnel gas pressure or $P_{bar} + P_{qg}$
 P_q = static pressure in H₂O
 { 13.6 }

 M_s = 28.56, wet molecular weight of stack gas (alternatively, it may be measured)

 K_p = 85.49 pitot tube constant, (conversion factor for English units)

 $\Delta_{p,avg}$ = average of the square roots of the velocity heads (Δ_p) measured at each traverse point.

CONTINUOUS ANALYZERS

 Date: 2018-07-31 Manufacturer: Acanalstone Model: Manchester
 Project #: PT 20174 Run: 2 Tech: MR Reviewer: DP

Pre-Test (Adjust and Record)

	ZERO		SPAN		CAL. (Record Only)	
	Actual	Should Be	Actual	Should Be	Actual	Should Be
CO	0	0	2,990	3,000	1,009	1,000
Tolerance CO		+/- 0.02		+/- 0.15		+/- 0.05
CO ₂	0	0	17,98	18,00	9,75	10,00
Tolerance CO ₂		+/- 0.02		+/- 0.5		+/- 0.5
O ₂ informative CSA B415 calculated value	na	na	na	na	na	na
	Actual	Should Be	Actual	Should Be	Actual	Should Be

Post Test (Record Only)

	Zero	Span	Cal.	Zero Drift	Limit	Span Drift	Limit	Cal. Drift	Limit	OK?	Not OK*
CO	0	2,985	1,005	0	0.02	0.005	0.15	0.009	0.05	✓	
CO ₂	0	17,95	9,71	0	0.02	0.03	0.5	0.04	0.5	✓	

Date: 2018.07.31 Manufacturer: Hearshstone Model: Manchester
 Project #: PI 20174 Run: 2 Tech: MM Reviewer: DP

RAW DRY GAS METER READINGS

	System 1	System 2	Blanck
Final (Liter)	743481,35	697135,58	320,76
Initial (Liter)	741900,41	695115,09	165,60

AMBIENT CONDITIONS

	Before	After
Barometer (kPa):	101,4	101,0
Dry Bulb (F):	79,70	86,90
Humidity (%):	50,0	41

Flow Meter

	Start	End
Flow meter reading	NA	NA

Flow Meter Verification

	Before	After
Flow meter Check (liters)	NA	NA
Scale Weight (Kg)	NA	NA

FUEL DATA

Date: 2018-07-31 Manufacturer: Heartstone Model: Manchester
 Project #: PI 20174 Run: 2 Tech: MM Reviewer: SD

FUEL DESCRIPTION:

Type of wood:

PRE-TEST LOAD

Piece Size	Weight	Meter Moisture Content (% dry)*				
1 1/2 x 3 1/2 x 18 in.	2090 lbs.	196	197	191	198	197
1 1/2 x 3 1/2 x 18 in.	2126 lbs.	198	197	199	192	192
1 1/2 x 3 1/2 x 18 in.	2124 lbs.	201	200	204	209	201
1 1/2 x 3 1/2 x 18 in.	2258 lbs.	206	209	204	205	203
1 1/2 x 3 1/2 x 11 in.	0904 lbs.	198	191	198	193	192
1 1/2 x 3 1/2 x 11 in.	1264 lbs.	191	192	194	195	192
1 1/2 x 3 1/2 x 11 in.	0850 lbs.	200	206	207	211	209
1 1/2 x 3 1/2 x 11 in.	1316 lbs.	201	204	209	200	201
x x in.	lbs.					
1 1/2 x 3 x 18 in.	1716 lbs.	202	202	208	206	209
1 1/2 x x 18 in.	1878 lbs.	204	206	209	207	208
1 1/2 x x 18 in.	1778 lbs.	209	199	198	207	204
1 1/2 x x 18 in.	1874 lbs.	213	210	200	219	208
1 1/2 x x 11 in.	0974 lbs.	218	210	213	210	210
1 1/2 x x 11 in.	1308 lbs.	198	197	196	197	194
1 1/2 x x 11 in.	1310 lbs.	198	193	193	199	201
1 1/2 x x 11 in.	1304 lbs.	200	201	204	208	206
1 1/2 x x 11 in.	0906 lbs.	195	192	191	194	198
x x in.	lbs.					
x x in.	lbs.					
x x in.	lbs.					
x x in.	lbs.					
x x in.	lbs.					

TEST LOAD WEIGHT: 2606 lbs

FUEL DATA

Date: 2018-07-31 Manufacturer: Hearthstone Model: manchester
 Project #: PZ 20174 Run: 2 Tech: MR Reviewer: [Signature]

FUEL DESCRIPTION:

Type of wood :

TEST LOAD

Piece Size	Weight	Meter Moisture Content (% dry)*						
1 1/2 x 3 1/2 x 20 3/4 in.	2410 lbs.	193	191	194	195	192		
1 1/2 x 3 1/2 x 20 3/4 in.	2518 lbs.	206	207	208	197	207		
3 1/2 x 3 1/2 x 20 1/4 in.	5086 lbs.	192	196	193	194	196		
3 1/2 x 3 1/2 x 20 3/4 in.	5290 lbs.	196	194	193	194	195		
1 1/2 x 3/4 x 5 in.	0104 lbs.			194				
1 1/2 x 3/4 x 5 in.	0108 lbs.			198				
1 1/2 x 3/4 x 5 in.	0104 lbs.			197				
1 1/2 x 3/4 x 5 in.	0108 lbs.			197				
1 1/2 x 3/4 x 5 in.	0118 lbs.			201				
1 1/2 x 3/4 x 5 in.	0122 lbs.			203				
1 1/2 x 3/4 x 5 in.	0118 lbs.			209				
1 1/2 x 3/4 x 5 in.	0104 lbs.			208				
1 1/2 x 3/4 x 5 in.	0120 lbs.			203				
1 1/2 x 3/4 x 5 in.	0108 lbs.			209				
1 1/2 x 3/4 x 5 in.	0108 lbs.			206				
1 1/2 x 3/4 x 5 in.	0106 lbs.			207				
x x in.	lbs.							
x x in.	lbs.							
x x in.	lbs.							
x x in.	lbs.							
x x in.	lbs.							
x x in.	lbs.							
x x in.	lbs.							
x x in.	lbs.							
x x in.	lbs.							
x x in.	lbs.							
x x in.	lbs.							
x x in.	lbs.							

TEST LOAD WEIGHT: 11663 lbs Min 20%: 332 Max 25%: 415



DILUTION TUNNEL PARTICULATE SAMPLER DATA

Date: 2018-07-30

Manufacturer: Heathstone

Model: Manchester

Project #: PI 20174

Run: 2

Tech: MM

Reviewer: DP

Pre-test Weight Record		SYSTEM 1 - 1 st hour						SYSTEM 1						
Date	Time	Probe & Housing Number	Front Filter Number	Back Filter Number	gaskets	Probe & Housing Number	Front Filter Number	Back Filter Number	gaskets	Probe & Housing Number	Front Filter Number	Back Filter Number	gaskets	Blank
2018-07-30	18:00	614560	01246	01250	347663	615050	01239	01284	354491	615051	01239	01284	354442	01296
2018-07-31	9:00	614559	01246	01250	347663	615051	01239	01284	354442					01297

Post-test Weight Record		SYSTEM 1 - 1 st hour						SYSTEM 1						
Date	Time	Probe & Housing Number	Front Filter Number	Back Filter Number	gaskets	Probe & Housing Number	Front Filter Number	Back Filter Number	gaskets	Probe & Housing Number	Front Filter Number	Back Filter Number	gaskets	Blank
2018-07-31	19:30	614565	01251	01249	347710	615060	01235	01276	354487	615060	01235	01276	354467	01302
2018-08-08	7:00	614560	01244	01244	347678	615052	01229	01272	354467	615052	01229	01272	354467	01298
2018-08-09	8:00	614560	01244	01244	347678	615052	01229	01272	354467	615052	01229	01272	354467	01298



DILUTION TUNNEL PARTICULATE SAMPLER DATA

Date: 2018-07-30 Manufacturer: Heartth stent Model: Manchester

Project #: PI 2016 Run: 2 Tech: MM Reviewer: SP

Mr PI 20174

SYSTEM 2					
Pre-test Weight Record	Probe & Housing Number	Front Filter Number	Back Filter Number	gaskets	
Date	Time				
2018-07-30	18:00	30	730	731	26
		110 2305	0 1271	0 1271	34 6968
		110 2306	0 1270	0 1270	34 6967

SYSTEM 2					
Post-test Weight Record	Probe & Housing Number	Front Filter Number	Back Filter Number	gaskets	
Date	Time				
2018-07-31	19:30	30	730	731	26
		110 2312	0 1272	0 1274	34 7009
		110 2307	0 1268	0 1270	34 6980
		110 2307	0 1268	0 1270	34 6980

Paramètres

Tous les facteurs de corrections et autres paramètres qui peuvent être modifiés par l'utilisateur du fichier sont regroupés ici.

Code verrouillage:

HEA

Description du test

Test standard	EPA
Run #	3
Date	01-09-2018
Technicien	M.M
Project #	P-20174

Description de l'unité

Manufacturier	HEARTHSTONE	
Modèle	MANCHESTER	
Combustion system	Cat	
Appliance type	WOODSTOVE	
Firebox volume	2,45	cu ft.
Appliance weight empty	N.A	lbs
Appliance weight full	N.A	lbs

Paramètres du test

Logging time	1	min
Manufacturer's rated heat output	N.A	BTU/h Donnée fournie par le manufacturier
Targeted category	1	
Targeted output	N.A	BTU/h
Cp steel	N.A	BTU/lb-°F

Échantillonnage

Blank sampling rate	0,20	cuft/min
Internal probe diameter	0,18	in.
Calibration Factor (DGM #1):	0,988	Dimensionless
Equipment number (DGM #1):	EM 178	
Calibration Factor (DGM #2):	0,991	Dimensionless
Equipment number (DGM #2):	EM 179	
Calibration Factor (DGM #3):	0,996	Dimensionless
Equipment number (DGM #3):	EM 070	Dimensionless

Tunnel

Targeted tunnel flow rate	300	scfm
Tunnel diameter	8	in.
Molecular weight	28,78	May be assumed to be 28,78 (EPA) Si B-415 = 29
Pitot tube type	Standard	
Pitot tube coefficient	0,99	Dimensionless

Project nu.	P-20174
Date	01-09-2018
Technicien	M.M

Fuel data

Fuel type	Dimension	
Fuel specie	D. Fir	
HHV	19810,0	kJ/kg
%C	48,7	
%H	6,9	
%O	43,9	
%Ash	0,5	
HHV	8519,2	Btu/lb
LHV	7451,0	Btu/lb

Default Fuel Values		
	D. Fir	Oak/Maple
HHV	19 810	19 887
%C	48,73	50
%H	6,87	6,6
%O	43,9	42,9
%Ash	0,5	0,5
HHV (Btu/lb)	8519	8552
LHV (Btu/lb)	7451	7480

	Start	End
Barometer (kPa):	101	100,5
Barometer (in.Hg):	29,825289	29,67763883
Dry Bulb (F):	81,68	88,52
Humidity (%):	47	46
Air velocity (ft/min)	41	43

DGM #1	Final:	26300,227	cuft
	Initial:	26256,058	cuft
DGM #2	Final:	24662,973	cuft
	Initial:	24619,209	cuft
DGM room			

	Final:	744739,490	Liter
	Initial:	743488,750	Liter
	Final:	698377,620	Liter
	Initial:	697138,350	Liter
	Final:	411,950	cuft
	Initial:	320,760	cuft

Numéro de la ligne dans "Raw data" à partir duquel les données du VRAI test commencent

203

Autres données à rentrer: dans preload data, load data, traverse et filter set weight

Project nu.	P-20174
Date	01-09-2018
Technicien	M.M

Tunnel Traverse Worksheet (for velocity calculations)

Static Pressure: 0,19 in. H2O
 Barometer: 29,900 in. Hg

Pour un tunnel de 12" et plus, prendre 6 lectures

	TUNNEL VELOCITY	TUNNEL TEMP	SQUARE ROOT
	In. wc	°F	
A center			0,0000
B center			0,0000
A1			0,0000
A2			0,0000
A3			0,0000
A4			0,0000
A5			0,0000
A6			0,0000
B1			0,0000
B2			0,0000
B3			0,0000
B4			0,0000
B5			0,0000
B6			0,0000
AVERAGE	#DIV/0!	#DIV/0!	0,0000

PITOT CONSTANT=
0,972

Pour un tunnel moins de 12", prendre 4 lectures

	TUNNEL VELOCITY	TUNNEL TEMP	SQUARE ROOT
	In. wc	°F	
A center	0,058	79,54	0,2408
B center	0,057	79,64	0,2387
A1	0,048	79,54	0,2191
A2	0,050	79,48	0,2236
A3	0,068	79,58	0,2608
A4	0,049	79,58	0,2214
B1	0,048	79,640	0,2191
B2	0,067	79,570	0,2588
B3	0,053	79,580	0,2302
B4	0,048	79,580	0,2191
AVERAGE	0,0546	79,5730	0,2332

Project nu.	P-20174
Date	01-09-2018
Technicien	M.M

Filter set weight

	System 1 (g) 1st hour				System 1 (g)				System 2 (g)				Ambient blank (g)	Date	Heure
	probe	front	back	gasket	probe	front	back	gasket	probe	front	back	gasket	Filter		
Number	19	734	735	1	31	736	737	4	33	738	739	39	740		
Before (1)															
Before (2)															
Before (3)															
Before (4)															
Before (5)	109,0910	0,1236	0,1255	34,5251	110,1290	0,1280	0,1224	34,5043	109,3629	0,1266	0,1266	34,4531	0,1255	2018-07-31	19:00
Before (6)	109,0909	0,1235	0,1256	34,5250	110,1289	0,1279	0,1225	34,5044	109,3628	0,1267	0,1265	34,4532	0,1256	2018-08-01	09:00
After (1)	109,0911	0,1229	0,1258	34,5288	110,1290	0,1281	0,1222	34,5078	109,3630	0,1267	0,1263	34,4572	0,1261	2018-08-01	16:00
After (2)	109,0909	0,1225	0,1255	34,5270	110,1290	0,1277	0,1221	34,5058	109,3628	0,1268	0,1261	34,4551	0,1258	2018-08-08	08:00
After (3)	109,0909	0,1225	0,1255	34,5270	110,1290	0,1277	0,1221	34,5058	109,3628	0,1268	0,1261	34,4551	0,1257	2018-08-09	08:00
After (4)															
After (5)															
After (6)	109,0909	0,1225	0,1255	34,5270	110,1290	0,1277	0,1221	34,5058	109,3628	0,1268	0,1261	34,4551	0,1257	2018-08-09	08:00
Difference	0,0000	-0,0010	-0,0001	0,0020	0,0001	-0,0002	-0,0004	0,0014	0,0000	0,0001	-0,0004	0,0019	0,0001		
Total (mg)		0,9			1,8				1,6				0,1		
Total ajusté (mg)		0,80			1,70				1,50						

Project nu.	P-20174
Date	01-09-2018
Technicien	M.M

SFBA EPA EMISSION RESULTS

RESULTS

Average emission rate: 0,8 g/hr
 Burn Rate : 1,549 Dry kg/hr

Test Duration: 244 min

PRESSURE FACTOR: DGM 1 0,97464
 DGM 2 0,97669
 DGM 3 0,99437

BAROMETRIC PRESSURE
 Average: 29,751464 in Hg
 Start: 29,825289 in Hg
 End: 29,677639 in Hg

TEMPERATURE FACTORS DGM 1 0,96394
 DGM 2 0,96412
 DGM 3 0,96816

DGM CONTROLLER VALUES
 DGM 1 Final: 26300,227 Cuft
 Initial: 26256,058 Cuft

VOLUMES SAMPLED DGM 1 41,019 Scft
 DGM 2 40,856 Scft
 DGM 3 87,417 Scft

DGM 2 Final: 24662,973 Cuft
 Initial: 24619,209 Cuft

DGM #3 Final: 411,950 Cuft
 Initial: 320,760 Cuft

TOTAL TUNNEL VOLUME : 76520

TEMPERATURES
 DGM 1 547,754 °R
 DGM 2 547,648 °R

SAMPLE RATIOS
 Sample Train 1: 1865,492
 Sample Train 2: 1872,901

CALIBRATION FACTORS
 DGM 1 0,9885
 DGM 2 0,9914
 DGM #3 0,9958

Paticulate concentration
 Sample Train 1 **0,000044** g/dscf
 Sample Train 2 **0,000039** g/dscf
 Room **0,000001** g/dscf

TUNNEL FLOW RATE: 313,606 Dscfm

TOTAL EMISSIONS
 Sample Train 1 **3,27** g
 Sample Train 2 **2,91** g

PARTICULATE CATCH
 Total Sample Train 1: 1,80 mg
 Total Sample Train 2: 1,60 mg
 Total Sample Train 1 1st hour: 0,90 mg

EMISSION RATES
 Sample Train 1 **0,80** g/hr
 Sample Train 2 **0,72** g/hr

1st hour emission rate **1,68** g/hr

DEVIATION: 5,85%

Cs Train 1 Train 2
 4,388E-05 3,91616E-05

Elapsed Time min	Raw data row	Weight Remaining lbs	CO %	CO ₂ %	O ₂ %	Flue Gas %F	Room Temp °F	Tunnel Dry Bulb °F	Unit					Catalyst Down °F	Reading cuft/min	Inlet T °F	Outlet T °F	Temp °F	Reading cuft/min	Inlet T °F	Outlet T °F	Temp °F
									Unit Top °F	Unit Back °F	Unit R.Side °F	Unit L.Side °F	Unit Bottom °F									
0.00	203.00	16.6	0.1	2.4	0.0	309.0	84.1	110.9	398.5	335.6	469.9	295.4	259.2	544.3	0.17	86.70	87.05	87.01	0.16	86.69	86.49	87.48
1.0	204.0	16.3	0.1	4.6	0.0	339.9	83.9	103.8	397.2	334.9	468.4	294.4	259.2	650.7	0.17	86.62	87.02	86.96	0.16	86.66	86.47	87.32
2.0	205.0	16.2	0.0	6.9	0.0	373.1	83.6	105.0	401.1	335.7	466.5	293.0	259.9	734.7	0.17	86.57	86.97	86.95	0.16	86.62	86.45	87.38
3.0	206.0	16.0	0.1	9.6	0.0	403.0	83.6	106.5	410.4	339.0	465.0	291.9	259.5	808.9	0.17	86.53	86.95	86.99	0.16	86.58	86.43	87.59
4.0	207.0	15.8	0.5	11.8	0.0	443.6	83.9	109.2	424.0	345.3	460.4	290.4	259.5	983.8	0.17	86.53	86.91	86.99	0.16	86.55	86.41	87.83
5.0	208.0	15.6	0.7	12.8	0.0	430.2	84.0	105.5	436.3	351.5	456.6	290.0	259.8	994.6	0.17	86.52	86.90	86.90	0.16	86.57	86.42	87.91
6.0	209.0	15.4	0.1	9.5	0.0	398.4	83.8	103.1	443.5	351.9	453.5	290.3	259.9	882.1	0.17	86.55	86.89	86.95	0.16	86.56	86.44	87.86
7.0	210.0	15.3	0.0	8.6	0.0	383.0	83.8	103.2	449.0	350.8	449.9	290.2	259.3	833.6	0.17	86.56	86.89	86.98	0.16	86.57	86.43	87.91
8.0	211.0	15.1	0.0	9.6	0.0	378.4	83.9	102.1	453.6	350.1	446.4	290.4	259.1	833.7	0.17	86.57	86.87	86.96	0.16	86.57	86.43	87.95
9.0	212.0	15.0	0.0	10.4	0.0	378.7	83.6	103.0	457.5	350.2	443.2	290.7	258.8	862.4	0.17	86.54	86.85	86.98	0.16	86.56	86.45	88.02
10.0	213.0	14.8	0.0	10.3	0.0	379.5	83.8	101.5	461.5	350.3	440.2	291.4	258.4	872.0	0.17	86.55	86.86	86.98	0.16	86.56	86.44	88.06
11.0	214.0	14.7	0.0	10.7	0.0	383.7	83.6	102.3	465.7	351.4	437.6	291.8	258.3	900.0	0.17	86.54	86.84	87.00	0.16	86.55	86.43	88.13
12.0	215.0	14.5	0.0	10.9	0.0	389.4	83.6	102.6	470.3	352.7	435.0	292.6	258.2	940.4	0.17	86.50	86.83	87.03	0.16	86.51	86.42	88.23
13.0	216.0	14.3	0.7	11.9	0.0	397.3	83.6	102.8	475.8	355.0	432.7	293.4	257.9	972.8	0.17	86.45	86.80	87.06	0.16	86.50	86.43	87.84
14.0	217.0	14.2	0.3	11.6	0.0	402.0	83.7	104.1	481.6	357.6	430.8	294.0	256.8	989.8	0.17	86.43	86.78	87.09	0.16	86.47	86.43	87.37
15.0	218.0	14.0	0.1	11.4	0.0	404.6	83.8	103.2	487.8	359.8	429.2	294.8	256.1	989.6	0.17	86.45	86.78	87.10	0.16	86.45	86.41	87.02
16.0	219.0	13.8	0.1	11.3	0.0	408.9	83.4	105.1	493.4	361.4	427.8	295.8	255.1	998.6	0.17	86.41	86.76	87.20	0.16	86.42	86.40	86.81
17.0	220.0	13.7	0.2	11.4	0.0	412.2	83.9	103.7	499.2	362.8	426.2	296.8	254.9	1005.5	0.17	86.40	86.78	87.26	0.16	86.40	86.39	86.62
18.0	221.0	13.5	0.4	11.8	0.0	415.9	83.6	104.7	504.3	364.6	425.0	298.1	254.8	1009.1	0.17	86.37	86.76	87.31	0.16	86.38	86.38	86.47
19.0	222.0	13.3	0.5	11.8	0.0	418.9	83.6	104.6	509.2	366.0	424.2	299.1	253.6	1014.8	0.17	86.38	86.73	87.34	0.16	86.37	86.35	86.36
20.0	223.0	13.2	0.5	11.9	0.0	422.0	83.6	104.3	514.5	367.7	423.6	300.5	252.9	1020.3	0.17	86.40	86.72	87.31	0.16	86.37	86.34	86.22
21.0	224.0	13.0	0.5	12.0	0.0	423.9	83.8	104.6	519.3	369.5	423.0	301.5	252.1	1014.8	0.17	86.44	86.73	87.34	0.16	86.37	86.34	86.14
22.0	225.0	12.8	0.8	12.0	0.0	426.2	83.3	104.5	524.6	371.4	422.5	303.1	251.3	1008.8	0.17	86.45	86.74	87.37	0.16	86.41	86.36	86.08
23.0	226.0	12.6	1.0	12.0	0.0	427.8	84.0	104.2	529.8	374.2	422.3	304.7	250.7	1003.7	0.17	86.40	86.71	87.37	0.16	86.41	86.36	86.00
24.0	227.0	12.5	1.1	12.0	0.0	428.8	83.8	104.8	534.9	373.8	422.3	306.2	251.3	1008.6	0.17	86.45	86.69	87.37	0.16	86.42	86.37	85.95
25.0	228.0	12.3	1.2	12.0	0.0	430.6	83.9	106.1	539.2	375.5	422.5	307.3	250.4	1015.1	0.17	86.46	86.72	87.38	0.16	86.44	86.42	85.96
26.0	229.0	12.1	1.2	12.0	0.0	431.1	83.8	106.0	542.7	376.8	422.5	308.9	249.0	1013.7	0.17	86.50	86.72	87.41	0.16	86.46	86.46	85.94
27.0	230.0	12.0	1.1	12.1	0.0	431.8	83.7	106.6	546.9	377.9	422.8	310.4	248.3	1016.3	0.17	86.54	86.72	87.44	0.16	86.50	86.45	85.95
28.0	231.0	11.8	1.3	12.1	0.0	432.6	84.0	106.0	550.0	379.9	423.0	312.0	247.9	1012.8	0.17	86.55	86.69	87.46	0.16	86.50	86.43	85.93
29.0	232.0	11.6	1.4	12.0	0.0	433.7	84.1	105.5	553.9	380.8	423.6	313.6	247.3	1010.0	0.17	86.63	86.71	87.54	0.16	86.54	86.44	85.91
30.0	233.0	11.5	1.4	12.1	0.0	433.7	83.9	105.6	557.1	381.6	424.0	315.3	247.1	1008.4	0.17	86.65	86.70	87.53	0.16	86.57	86.44	85.87
31.0	234.0	11.3	1.5	12.1	0.0	433.8	83.8	106.7	560.4	382.6	424.7	317.0	243.9	1008.4	0.17	86.70	86.72	87.54	0.16	86.61	86.45	85.84
32.0	235.0	11.1	1.4	12.2	0.0	434.6	83.9	106.9	563.2	383.2	425.6	318.6	243.7	1006.5	0.17	86.73	86.75	87.60	0.16	86.64	86.47	85.87
33.0	236.0	11.0	1.4	12.1	0.0	434.4	84.3	107.4	566.1	384.4	426.5	320.2	243.0	1005.5	0.17	86.71	86.74	87.59	0.16	86.65	86.36	85.86
34.0	237.0	10.8	1.3	12.1	0.0	434.3	84.1	107.1	568.9	384.0	427.3	321.6	242.4	1010.1	0.17	86.73	86.76	87.61	0.16	86.69	86.50	85.93
35.0	238.0	10.6	1.1	12.1	0.0	434.3	83.8	106.6	571.6	384.2	428.4	323.4	240.9	1013.9	0.17	86.79	86.76	87.63	0.16	86.74	86.52	85.99
36.0	239.0	10.5	1.0	12.1	0.0	433.9	84.3	106.8	574.1	384.8	429.5	324.5	240.0	1014.5	0.17	86.81	86.78	87.67	0.16	86.74	86.53	85.95
37.0	240.0	10.3	1.0	12.1	0.0	433.6	84.3	106.8	576.1	385.1	430.4	325.6	239.9	1019.1	0.17	86.88	86.81	87.77	0.16	86.78	86.56	86.01
38.0	241.0	10.2	0.9	12.1	0.0	434.2	84.3	106.3	578.3	385.8	431.3	326.3	239.5	1017.8	0.17	86.89	86.81	87.77	0.16	86.80	86.55	86.00
39.0	242.0	10.0	1.0	12.0	0.0	433.3	84.2	107.4	580.3	386.7	432.2	326.6	238.6	1017.9	0.17	86.87	86.80	87.80	0.16	86.80	86.57	86.03
40.0	243.0	9.8	1.1	12.1	0.0	433.4	84.4	106.9	581.5	387.5	433.2	327.9	237.6	1021.7	0.17	86.89	86.82	87.90	0.16	86.83	86.58	86.08
41.0	244.0	9.7	1.1	12.2	0.0	434.0	84.4	106.4	583.0	388.3	434.1	329.0	237.8	1023.2	0.17	86.94	86.84	87.90	0.16	86.89	86.61	86.08
42.0	245.0	9.5	1.0	12.3	0.0	434.8	84.2	106.8	585.1	389.1	434.7	330.2	236.8	1023.5	0.17	86.95	86.85	87.96	0.16	86.88	86.61	86.11
43.0	246.0	9.4	1.0	12.2	0.0	434.4	84.3	106.7	587.4	389.4	435.6	331.1	236.2	1021.5	0.17	86.99	86.85	88.05	0.16	86.91	86.62	86.13
44.0	247.0	9.2	1.0	12.2	0.0	433.7	84.2	106.4	589.7	389.7	436.5	332.4	235.8	1019.0	0.17	87.00	86.84	88.05	0.16	86.91	86.59	86.09
45.0	248.0	9.1	1.0	12.1	0.0	433.0	84.7	106.5	592.8	390.3	437.9	333.5	235.2	1017.6	0.17	87.02	86.84	88.02	0.16	86.95	86.63	86.09
46.0	249.0	8.9	0.9	12.0	0.0	432.6	84.5	106.1	595.2	390.5	439.0	334.3	233.8	1016.3	0.17	87.08	86.85	88.03	0.16	86.98	86.63	86.11
47.0	250.0	8.8	0.8	12.1	0.0	432.0	84.5	107.2	597.8	390.5	440.0	334.9	232.9	1015.2	0.17	87.11	86.89	88.03	0.16	87.00	86.65	86.15
48.0	251.0	8.7	0.9	12.0	0.0	431.3	84.5	106.0	600.2	390.4	441.0	335.4	232.7	1011.1	0.17	87.15	86.88	88.03	0.16	87.02	86.65	86.15
49.0	252.0	8.5	0.9	11.9	0.0	430.0	84.2	107.1	602.4	390.4	442.2	335.7	231.4	1008.0	0.17	87.21	86.88	88.05	0.16	87.04	86.64	86.15
50.0	253.0	8.4	0.9	12.1	0.0	430.5	84.5	106.2	603.6	390.2	443.2	336.3	231.4	1007.8	0.17	87.23	86.91	88.08	0.16	87.08	86.66	86.19
51.0	254.0	8.2	0.8	12.1	0.0	430.2	84.6	106.3	604.9	390.2	444.0	336.1	230.5	1005.3	0.17	87.25	86.91	88.14	0.16	87.09	86.65	86.20
52.0	255.0	8.1	0.8	12.1	0.0	429.2	84.8	105.8	608.8	390.6	445.1	336.9	230.0	1007.1	0.17	87.28	86.93	88.15	0.16	87.13		

90.0	293.0	4.1	0.1	10.6	0.0	377.9	85.2	102.2	566.2	376.0	480.2	358.7	214.2	859.3	0.17	87.63	87.25	87.95	0.16	87.55	87.06	86.06
91.0	294.0	4.1	0.1	10.6	0.0	376.2	84.9	102.2	564.9	375.3	480.4	359.2	213.8	857.6	0.17	87.60	87.27	87.97	0.16	87.57	87.05	86.04
92.0	295.0	4.0	0.1	10.5	0.0	375.2	85.2	101.6	563.9	375.1	480.9	359.5	213.4	852.6	0.17	87.64	87.26	87.99	0.16	87.56	87.06	86.01
93.0	296.0	3.9	0.1	10.5	0.0	374.0	84.9	103.0	562.8	374.4	481.5	359.7	213.8	845.7	0.17	87.61	87.29	88.02	0.16	87.54	87.06	86.02
94.0	297.0	3.8	0.1	10.2	0.0	371.7	85.0	101.8	561.5	374.1	482.0	360.3	212.9	839.0	0.17	87.60	87.30	88.07	0.16	87.55	87.04	86.02
95.0	298.0	3.8	0.0	9.8	0.0	368.2	85.1	101.8	559.4	373.7	482.3	360.2	212.3	830.4	0.17	87.61	87.30	88.09	0.16	87.54	87.05	86.00
96.0	299.0	3.7	0.0	9.5	0.0	364.7	85.0	101.3	556.6	372.7	482.3	360.3	213.4	819.7	0.17	87.58	87.30	88.16	0.16	87.55	87.07	85.95
97.0	300.0	3.7	0.0	8.8	0.0	361.1	84.8	100.7	554.0	371.3	482.3	360.5	212.2	808.7	0.17	87.57	87.30	88.19	0.16	87.54	87.07	85.91
98.0	301.0	3.6	0.0	8.7	0.0	356.2	84.9	100.5	550.5	369.7	482.3	359.9	212.8	799.4	0.17	87.57	87.31	88.20	0.16	87.55	87.07	85.90
99.0	302.0	3.6	0.0	8.6	0.0	352.3	85.1	101.1	546.9	368.8	482.1	360.0	212.7	791.2	0.17	87.53	87.30	88.22	0.16	87.51	87.07	85.86
100.0	303.0	3.5	0.0	8.5	0.0	349.3	84.8	99.9	543.0	367.6	481.7	359.3	212.4	785.1	0.17	87.54	87.30	88.25	0.16	87.48	87.04	85.82
101.0	304.0	3.5	0.0	8.5	0.0	346.5	85.0	100.2	539.2	366.5	481.5	358.9	212.9	779.6	0.17	87.50	87.29	88.25	0.16	87.46	87.04	85.80
102.0	305.0	3.4	0.0	8.4	0.0	342.6	85.2	100.3	535.6	365.5	481.1	358.6	213.3	773.8	0.17	87.47	87.28	88.28	0.16	87.44	87.04	85.79
103.0	306.0	3.4	0.0	8.1	0.0	339.3	85.0	99.2	531.5	364.2	480.7	358.1	212.9	765.6	0.17	87.47	87.28	88.29	0.16	87.43	87.02	85.71
104.0	307.0	3.4	0.0	7.8	0.0	336.9	84.9	99.3	526.7	363.1	479.7	357.7	212.8	761.3	0.17	87.46	87.30	88.28	0.16	87.43	87.03	85.68
105.0	308.0	3.3	0.0	7.6	0.0	334.4	85.1	99.1	522.2	362.1	478.9	357.1	212.3	759.5	0.17	87.45	87.29	88.29	0.16	87.44	87.03	85.64
106.0	309.0	3.3	0.0	7.5	0.0	331.1	85.1	98.2	517.0	361.3	478.1	356.4	212.5	754.1	0.17	87.48	87.29	88.30	0.16	87.43	87.04	85.60
107.0	310.0	3.2	0.0	7.5	0.0	328.4	85.3	97.7	511.9	360.2	477.4	355.2	211.9	748.7	0.17	87.44	87.28	88.31	0.16	87.42	87.06	85.54
108.0	311.0	3.2	0.0	7.2	0.0	326.7	85.3	97.2	506.7	359.0	476.3	353.9	211.3	744.9	0.17	87.45	87.29	88.32	0.16	87.44	87.08	85.48
109.0	312.0	3.2	0.0	7.1	0.0	324.2	85.4	97.1	501.7	357.5	475.1	352.3	211.7	745.7	0.17	87.48	87.30	88.31	0.16	87.46	87.09	85.44
110.0	313.0	3.2	0.0	7.1	0.0	322.3	85.4	96.7	496.7	356.5	474.4	350.6	211.3	746.8	0.17	87.48	87.31	88.28	0.16	87.47	87.11	85.37
111.0	314.0	3.1	0.0	7.0	0.0	320.5	85.6	97.0	491.8	355.8	473.3	348.9	211.2	748.2	0.17	87.56	87.33	88.27	0.16	87.52	87.13	85.34
112.0	315.0	3.1	0.0	7.0	0.0	318.7	83.4	96.9	486.6	354.5	471.9	347.3	209.3	748.6	0.17	87.60	87.34	88.25	0.16	87.55	87.14	85.29
113.0	316.0	3.1	0.0	7.0	0.0	317.4	83.3	96.6	482.0	353.4	470.7	345.4	208.9	746.7	0.17	87.63	87.35	88.23	0.16	87.59	87.15	85.25
114.0	317.0	3.1	0.0	7.0	0.0	315.4	86.4	97.2	477.2	351.4	469.6	343.3	210.1	747.4	0.17	87.67	87.37	88.24	0.16	87.63	87.17	85.22
115.0	318.0	3.0	0.0	7.0	0.0	314.1	86.1	96.0	472.3	350.6	468.3	341.3	209.2	749.7	0.17	87.72	87.40	88.26	0.16	87.67	87.23	85.20
116.0	319.0	3.0	0.0	7.1	0.0	313.4	85.9	96.0	468.1	349.0	467.3	339.2	209.2	749.7	0.17	87.76	87.42	88.29	0.16	87.69	87.23	85.17
117.0	320.0	3.0	0.0	7.2	0.0	311.0	86.5	96.3	464.1	348.2	465.9	337.6	208.2	745.3	0.17	87.78	87.45	88.25	0.16	87.71	87.24	85.15
118.0	321.0	3.0	0.0	7.2	0.0	310.2	86.2	96.1	459.8	346.7	464.8	335.6	207.9	744.8	0.17	87.75	87.45	88.28	0.16	87.72	87.28	85.14
119.0	322.0	2.9	0.0	7.3	0.0	308.2	86.2	95.9	455.9	345.7	463.6	333.7	207.9	743.1	0.17	87.74	87.46	88.28	0.16	87.73	87.29	85.07
120.0	323.0	2.9	0.0	7.3	0.0	306.4	85.9	95.8	452.2	344.5	462.5	331.8	208.0	740.7	0.17	87.80	87.49	88.29	0.16	87.77	87.32	85.06
121.0	324.0	2.9	0.0	7.3	0.0	305.0	85.9	96.2	448.7	343.3	461.2	329.8	207.4	739.6	0.17	87.75	87.50	88.31	0.16	87.78	87.35	85.06
122.0	325.0	2.8	0.0	7.5	0.0	304.0	86.0	96.1	445.5	342.1	459.7	328.1	206.6	738.4	0.17	87.72	87.52	88.28	0.16	87.77	87.37	85.04
123.0	326.0	2.8	0.0	7.5	0.0	302.8	86.1	96.1	441.9	341.0	459.0	326.4	205.7	737.0	0.17	87.72	87.54	88.26	0.16	87.77	87.37	85.03
124.0	327.0	2.8	0.0	7.5	0.0	301.4	85.8	95.8	438.6	339.9	458.1	324.5	207.5	735.1	0.17	87.70	87.54	88.30	0.16	87.78	87.39	85.02
125.0	328.0	2.8	0.0	7.6	0.0	300.8	85.7	95.7	436.7	338.9	457.5	322.8	207.5	733.8	0.17	87.73	87.56	88.30	0.16	87.80	87.43	84.99
126.0	329.0	2.7	0.0	7.7	0.0	300.2	86.4	95.7	434.0	338.3	456.3	321.6	205.4	733.4	0.17	87.74	87.57	88.32	0.16	87.78	87.43	84.98
127.0	330.0	2.7	0.0	7.7	0.0	299.3	86.2	95.7	431.5	337.6	455.6	320.3	206.0	733.3	0.17	87.72	87.59	88.26	0.16	87.79	87.46	84.94
128.0	331.0	2.7	0.0	7.7	0.0	298.3	86.2	95.6	429.3	336.5	454.5	319.2	204.9	734.4	0.17	87.74	87.60	88.29	0.16	87.82	87.46	84.93
129.0	332.0	2.7	0.0	7.8	0.0	298.2	85.7	95.7	427.2	335.5	454.1	317.6	206.6	737.4	0.17	87.78	87.61	88.30	0.16	87.83	87.46	84.93
130.0	333.0	2.6	0.0	7.8	0.0	297.4	86.0	95.6	425.0	334.7	452.9	316.3	205.8	738.8	0.17	87.84	87.63	88.28	0.16	87.87	87.47	84.93
131.0	334.0	2.6	0.0	7.8	0.0	297.0	86.1	95.4	423.0	334.3	452.0	315.2	205.2	739.4	0.17	87.82	87.65	88.30	0.16	87.87	87.50	84.90
132.0	335.0	2.6	0.0	7.8	0.0	296.5	86.0	95.7	420.9	333.5	451.6	314.3	205.1	741.5	0.17	87.80	87.67	88.28	0.16	87.88	87.52	84.90
133.0	336.0	2.5	0.0	7.8	0.0	296.0	86.1	95.4	418.8	333.0	451.0	313.5	204.8	742.6	0.17	87.82	87.69	88.29	0.16	87.89	87.53	84.90
134.0	337.0	2.5	0.0	7.9	0.0	295.9	86.1	95.4	416.9	332.6	450.3	312.5	206.0	740.1	0.17	87.84	87.69	88.30	0.16	87.90	87.53	84.86
135.0	338.0	2.5	0.0	7.9	0.0	294.9	85.8	95.6	415.2	331.4	449.9	311.5	205.9	733.6	0.17	87.89	87.71	88.31	0.16	87.93	87.53	84.87
136.0	339.0	2.5	0.0	7.9	0.0	294.2	86.2	95.4	413.7	331.0	449.5	311.0	204.5	728.2	0.17	87.92	87.73	88.30	0.16	87.95	87.54	84.87
137.0	340.0	2.4	0.0	7.9	0.0	293.4	86.1	95.4	412.2	330.7	449.0	310.3	204.9	727.7	0.17	87.95	87.75	88.30	0.16	87.96	87.55	84.86
138.0	341.0	2.4	0.0	8.0	0.0	292.2	85.6	95.4	410.9	329.5	448.5	309.5	202.6	727.5	0.17	87.96	87.75	88.31	0.16	87.98	87.56	84.88
139.0	342.0	2.4	0.0	8.0	0.0	291.9	85.6	95.4	409.5	328.7	448.2	308.8	207.0	728.4	0.17	87.99	87.76	88.30	0.16	87.99	87.56	84.84
140.0	343.0	2.3	0.0	8.0	0.0	291.8	86.0	95.3	408.3	328.0	447.9	308.5	207.4	732.5	0.17	88.04	87.78	88.32	0.16	88.03	87.55	84.84
141.0	344.0	2.3	0.0	8.0	0.0	291.8	86.3	95.5	406.9	327.5	447.2	308.0	206.4	731.2	0.17	88.11	87.82	88.36	0.16	88.06	87.59	84.86
142.0	345.0	2.3	0.0	8.0	0.0	291.1	86.0	95.3	405.9	327.7	446.7	307.4	205.6	730.6	0.17	88.08	87.83	88.37	0.16	88.06	87.61	84.83
143.0	346.0	2.3	0.0	8.0	0.0	291.4	86.2	95.4	404.3	327.2	446.2	306.8	207.0	734.3	0.17	88.07	87.84	88.35	0.16	88.08	87.61	84.84
144.0	347.0	2.2	0.0	8.0	0.0	291.8	86.0	95.4	403.3	326.7	445.9	306.6	206.0	732.0	0.17	88.09	87.87	88.38	0.16	88.08	87.63	84.86
145.0																						

183.0	386.0	1,3	0,0	7,3	0,0	289,6	86,0	95,7	372,6	317,2	433,1	289,1	214,1	738,3	0,17	88,43	88,38	88,75	0,16	88,50	88,18	85,05
184.0	387.0	1,3	0,0	7,3	0,0	289,3	85,9	95,5	372,0	316,3	432,7	289,2	214,9	738,7	0,17	88,44	88,40	88,74	0,16	88,51	88,20	85,05
185.0	388.0	1,3	0,0	7,3	0,0	289,7	86,0	95,6	371,4	315,9	432,3	288,9	214,7	740,2	0,17	88,49	88,43	88,79	0,16	88,55	88,23	85,08
186.0	389.0	1,2	0,0	7,2	0,0	289,7	86,2	95,6	370,7	316,1	431,7	288,8	214,0	742,3	0,17	88,51	88,45	88,81	0,16	88,58	88,23	85,07
187.0	390.0	1,2	0,0	7,1	0,0	290,4	86,3	95,7	370,2	316,1	431,3	288,1	213,9	748,3	0,17	88,54	88,49	88,84	0,16	88,62	88,28	85,09
188.0	391.0	1,2	0,0	7,1	0,0	290,8	86,5	95,6	369,8	315,8	430,8	287,6	214,0	751,4	0,17	88,55	88,49	88,84	0,16	88,63	88,30	85,11
189.0	392.0	1,2	0,0	7,0	0,0	291,1	85,7	95,9	369,1	315,7	430,1	287,4	214,5	752,3	0,17	88,55	88,51	88,86	0,16	88,65	88,33	85,10
190.0	393.0	1,2	0,0	7,0	0,0	291,4	86,0	95,9	368,2	315,6	429,5	286,9	214,5	752,4	0,17	88,61	88,54	88,88	0,16	88,68	88,36	85,12
191.0	394.0	1,1	0,0	7,0	0,0	291,4	86,5	95,9	367,5	315,7	429,0	286,7	213,3	751,3	0,17	88,68	88,57	88,91	0,16	88,72	88,39	85,14
192.0	395.0	1,1	0,0	7,0	0,0	291,8	85,9	96,1	367,0	315,3	428,5	286,2	214,4	748,7	0,17	88,69	88,59	88,94	0,16	88,76	88,41	85,17
193.0	396.0	1,1	0,0	6,9	0,0	290,9	86,4	96,0	366,5	314,9	427,9	285,9	213,8	740,3	0,17	88,75	88,62	88,97	0,16	88,79	88,44	85,17
194.0	397.0	1,1	0,0	7,0	0,0	289,7	86,1	96,1	365,8	314,3	427,5	285,9	214,5	729,8	0,17	88,78	88,63	88,99	0,16	88,86	88,48	85,18
195.0	398.0	1,0	0,0	6,8	0,0	289,0	86,7	96,4	365,5	313,9	426,8	285,6	213,5	726,0	0,17	88,88	88,67	89,03	0,16	88,93	88,51	85,22
196.0	399.0	1,0	0,0	6,8	0,0	289,3	86,6	96,4	365,4	312,9	426,1	285,6	214,4	726,2	0,17	88,92	88,69	89,04	0,16	88,95	88,52	85,23
197.0	400.0	1,0	0,0	6,8	0,0	289,4	86,3	96,2	364,9	312,5	425,3	285,1	214,3	728,0	0,17	88,95	88,74	89,08	0,16	89,01	88,57	85,24
198.0	401.0	1,0	0,0	6,8	0,0	290,0	86,4	96,3	364,5	312,2	424,7	284,4	214,4	730,5	0,17	88,98	88,75	89,12	0,16	89,04	88,60	85,27
199.0	402.0	1,0	0,0	6,8	0,0	289,9	86,6	96,5	364,3	311,4	424,3	284,1	214,2	732,5	0,17	89,06	88,78	89,17	0,16	89,10	88,63	85,28
200.0	403.0	1,0	0,0	6,8	0,0	290,6	85,8	96,5	364,2	311,1	423,8	283,7	214,1	733,5	0,17	89,12	88,84	89,21	0,16	89,14	88,67	85,33
201.0	404.0	0,9	0,0	6,7	0,0	290,4	86,7	96,5	364,0	310,8	423,0	283,6	214,3	734,4	0,17	89,14	88,84	89,24	0,16	89,19	88,70	85,36
202.0	405.0	0,9	0,0	6,7	0,0	291,0	86,2	96,7	363,6	310,5	422,6	283,1	213,8	735,4	0,17	89,18	88,86	89,26	0,16	89,20	88,71	85,35
203.0	406.0	0,9	0,0	6,8	0,0	290,7	86,0	96,4	363,5	309,8	422,4	282,9	214,4	734,0	0,17	89,20	88,89	89,31	0,16	89,25	88,75	85,40
204.0	407.0	0,9	0,0	6,8	0,0	290,4	86,4	96,5	362,8	309,9	421,9	282,3	213,4	732,8	0,17	89,21	88,92	89,35	0,16	89,26	88,77	85,43
205.0	408.0	0,8	0,0	6,8	0,0	290,5	86,6	96,3	362,5	309,4	421,4	282,1	214,2	733,5	0,17	89,19	88,94	89,39	0,16	89,28	88,79	85,43
206.0	409.0	0,8	0,0	6,8	0,0	290,0	86,7	96,3	362,3	309,0	421,2	281,6	213,5	733,8	0,17	89,17	88,93	89,39	0,16	89,24	88,77	85,43
207.0	410.0	0,8	0,0	6,8	0,0	290,2	86,4	96,3	362,0	308,5	420,8	281,2	213,6	735,3	0,17	89,15	88,94	89,45	0,16	89,22	88,78	85,43
208.0	411.0	0,8	0,0	6,8	0,0	290,4	86,5	96,1	361,2	308,0	420,3	280,7	213,0	736,4	0,17	89,18	88,98	89,48	0,16	89,24	88,79	85,44
209.0	412.0	0,8	0,0	6,8	0,0	290,8	86,5	96,1	360,6	307,5	420,0	280,0	213,4	736,9	0,17	89,15	88,98	89,50	0,16	89,22	88,78	85,46
210.0	413.0	0,7	0,0	6,7	0,0	290,9	86,2	96,0	360,3	306,9	419,8	279,9	213,5	736,6	0,17	89,12	88,98	89,49	0,16	89,21	88,80	85,48
211.0	414.0	0,7	0,0	6,7	0,0	290,3	86,4	95,8	359,8	306,7	419,4	279,2	213,4	736,0	0,17	89,10	88,99	89,49	0,16	89,21	88,79	85,48
212.0	415.0	0,7	0,0	6,7	0,0	290,2	86,8	95,8	359,6	306,4	419,1	278,9	213,1	735,6	0,17	89,08	88,99	89,51	0,16	89,19	88,79	85,48
213.0	416.0	0,7	0,0	6,7	0,0	290,4	86,1	95,9	359,1	305,9	418,7	278,4	213,2	734,4	0,17	89,05	89,00	89,53	0,16	89,17	88,79	85,54
214.0	417.0	0,7	0,0	6,7	0,0	289,5	87,0	95,9	358,6	306,2	418,0	277,7	212,0	732,3	0,17	89,01	89,00	89,54	0,16	89,12	88,77	85,52
215.0	418.0	0,6	0,0	6,7	0,0	289,8	86,7	95,7	358,0	305,5	417,6	277,3	212,4	731,1	0,17	88,98	88,99	89,55	0,16	89,09	88,78	85,54
216.0	419.0	0,6	0,0	6,7	0,0	289,9	86,7	95,7	357,4	304,8	417,3	277,1	212,2	731,2	0,17	88,92	89,00	89,54	0,16	89,06	88,74	85,53
217.0	420.0	0,6	0,0	6,6	0,0	290,0	86,4	95,8	356,9	304,4	416,9	276,5	212,2	735,2	0,17	88,92	89,00	89,54	0,16	89,04	88,74	85,55
218.0	421.0	0,6	0,0	6,6	0,0	289,5	86,6	95,6	356,4	303,9	416,5	276,2	210,0	735,4	0,17	88,87	88,99	89,53	0,16	89,02	88,74	85,53
219.0	422.0	0,6	0,0	6,5	0,0	289,2	86,4	95,6	356,0	303,5	416,0	275,5	210,8	734,2	0,17	88,85	89,00	89,54	0,16	89,01	88,76	85,53
220.0	423.0	0,5	0,0	6,5	0,0	289,3	86,6	95,5	355,5	303,0	415,8	275,2	209,8	735,7	0,17	88,84	88,99	89,52	0,16	88,97	88,74	85,55
221.0	424.0	0,5	0,0	6,5	0,0	289,2	86,7	95,2	355,2	302,7	415,4	274,6	210,4	737,3	0,17	88,82	88,98	89,50	0,16	88,95	88,73	85,52
222.0	425.0	0,5	0,0	6,5	0,0	289,7	86,7	95,2	354,6	302,0	415,0	274,4	209,2	738,5	0,17	88,77	88,98	89,52	0,16	88,93	88,72	85,55
223.0	426.0	0,5	0,0	6,4	0,0	289,5	86,4	95,2	354,3	301,7	414,2	273,9	209,8	739,7	0,17	88,75	88,97	89,49	0,16	88,90	88,72	85,53
224.0	427.0	0,4	0,0	6,4	0,0	288,6	86,5	95,1	353,8	301,3	413,9	273,6	208,7	741,0	0,17	88,70	88,98	89,47	0,16	88,87	88,73	85,56
225.0	428.0	0,4	0,0	6,4	0,0	288,8	86,3	95,2	353,1	300,5	413,3	273,3	209,1	743,2	0,17	88,68	88,97	89,47	0,16	88,85	88,73	85,54
226.0	429.0	0,4	0,0	6,4	0,0	289,1	86,3	95,0	352,9	300,0	412,7	273,1	208,9	745,6	0,17	88,67	88,95	89,45	0,16	88,84	88,72	85,54
227.0	430.0	0,4	0,0	6,4	0,0	289,3	86,2	95,0	352,4	299,8	412,1	272,3	209,5	748,6	0,17	88,62	88,95	89,42	0,16	88,81	88,71	85,54
228.0	431.0	0,4	0,1	6,4	0,0	289,6	86,0	95,0	351,8	299,2	411,8	271,8	209,9	751,6	0,17	88,62	88,95	89,41	0,16	88,81	88,72	85,53
229.0	432.0	0,3	0,1	6,4	0,0	290,1	85,9	94,9	351,2	298,6	411,3	271,7	209,9	754,3	0,17	88,64	88,94	89,40	0,16	88,80	88,70	85,54
230.0	433.0	0,3	0,1	6,4	0,0	290,2	86,5	95,1	350,9	298,6	410,8	271,2	208,3	754,2	0,17	88,65	88,95	89,39	0,16	88,80	88,71	85,53
231.0	434.0	0,3	0,0	6,4	0,0	289,7	86,5	95,1	350,3	298,3	410,1	270,8	207,4	753,2	0,17	88,64	88,94	89,35	0,16	88,79	88,70	85,53
232.0	435.0	0,3	0,0	6,4	0,0	289,5	86,4	95,1	349,7	297,7	409,8	270,5	207,8	752,9	0,17	88,59	88,95	89,35	0,16	88,76	88,69	85,54
233.0	436.0	0,3	0,0	6,4	0,0	289,6	86,4	95,0	348,9	296,9	409,0	270,3	207,4	753,3	0,17	88,54	88,94	89,33	0,16	88,74	88,72	85,51
234.0	437.0	0,2	0,0	6,4	0,0	289,3	86,5	95,2	348,4	296,5	408,5	269,8	208,7	752,6	0,17	88,55	88,95	89,31	0,16	88,73	88,72	85,51
235.0	438.0	0,2	0,0	6,3	0,0	288,5	86,1	95,1	347,9	296,1	407,8	269,3	208,2	752,8	0,17	88,54	88,94	89,28	0,16	88,72	88,70	85,51
236.0	439.0	0,2	0,0	6,3	0,0	288,2	86,3	95,1	347,4	295,3	407,7	268,7	209,4	752,8	0,17	88,54	88,93	89,28	0,16	88,70	88,71	85,52
237.0	440.0	0,2	0,0	6,3	0,0	288,6	86,6	94,9	346,8	295,0	407,4	268,6	209,1	750,5	0,17	88,52	88,91	89,27	0,16	88,69	88,70	85,49
238.0	441																					

Manufacturer: HEARTHSTONE
 Model: MANCHESTER

Run: 3
 Project #: P-20174
 Test Duration: 244 min

	HHV	LHV
Eff	75,99%	82,13%
Comb Eff	97,25%	97,25%
HT Eff	78,14%	84,46%
Output	23 325	kJ/h
Burn Rate	1,55	kg/h
Grams CO	258	g
Input	30 694	kJ/h
MC wet	16,51	

Note: In the "Input data", "Calc. % O₂", "Fuel Properties", and "Mass Balance" columns, [e], [d], [g], [a], [b], [c], [h], [u], [w], [j], and [k] refer to their respective variables in Clauses 13.7.3

Ultimate CO₂
 CO_{2-ut} 19,64
 F_o
 1,062

Overall Heating Efficiency: 75,99%
 Combustion Efficiency: 97,25%
 Heat Transfer Efficiency: 78,14%

	Air Fuel Ratio (A/F)	
Dry Molecular Weight (M _d)		29,87
Dry Moles Exhaust Gas (N _g)		427,72
Air Fuel Ratio (A/F)		12,27

Heat Output:	22 127 Btu/h	23 325 kJ/h
Heat Input:	29 117 Btu/h	30 694 kJ/h
Burn Duration:	4,07 h	
Burn Rate:	3,41 lb/h	1,549 kg/h
Stack Temp:	341,7 Deg. F	172,1 Deg. C

PRE / POST CHECKS

Date: 2018-08-01 Manufacturer: Hearthstone Model: Manchester
 Project #: PT 20174 Run: 3 Tech: MR Reviewer: [Signature]

Moisture Meter Calibration Check:

Equipment #	Time	12%	22%
EM-191	7:00	OK	OK

Facility Conditions:

Air Velocity from less than 2 feet
 Smoke Capture Check.....
 Picture.....

	Pre-Test	Post-Test
	41 (max50 Fpm)	43 (max50 Fpm)
	OK	OK
4 sides	OK	OK

Wood Heater Conditions:

Date Wood Heater Stack Cleaned.....
 Date Dilution Tunnel Cleaned.....
 Induced Draft Check (max 0.005 H2O).....
 Traverse before ignition.....
 Flow Rate 140 cfm ±10%.....

2018-07-30	
2018-07-30	
OK	
OK	
	OK

Temperature System:

Ambient (65°-90°F).....
 Wood Heater Surface (±125°F).....

OK	°F
OK	°F

Proportional Checks:

Thermocouple check.....
 Pitot Clean.....
 Pitot verification.....

OK
OK
OK

Sampling Train ID Numbers:

Probe.....
 Filter Front.....
 Filter Back.....
 Filter Thermocouple.....
 Filter (<90°F).....

Train 1 st hour	Train 1	Train 2
19	31	33
734	736	738
735	737	739
11	11	12
OK	OK	OK



SAMPLING EQUIPMENT CHECK OUT

Date: 2018-08-01 Manufacturer: Health Stone Model: manchester
 Project #: PI 2174 Run: 3 Tech: MM Reviewer: DP

Leakage Checks Tunnel Samplers

Unplugged Flow Rate = .25cfm	System 1 st hour		System 1		System 2	
	Pre-Test ASTM (-15) CSA B415 (-5)	Post-Test (max test)	Pre-Test ASTM (-15) CSA B415 (-5)	Post-Test (Max test)	Pre-Test ASTM (-15) CSA B415 (-5)	Post-Test (Max test)
Vacuum (inches Hg.)	-15	-15	-15	-15	-15	-15
Final 1minute DGM (Liter)	743488.01	744740.54	743488.12	744740.63	697137.66	698378.80
Initial 1minute DGM (Liter)	743488.00	744740.53	743488.08	744740.62	697137.65	698378.80
Change © (Liter)	0.01	0.01	0.04	0.01	0.01	0
Allowable leakage .04 x Sample rate or 0.28Lpm CSA B415 (0.56)						
Check OK	OK	OK	OK	OK	OK	OK

Leakage Checks Flue Gas Sampler

Plugged Probe	Pre Test	Post Test
Vacuum (inches Hg.)	-5	-5
Rotometer Reading (mml/min.)	0	0
Flow Rate (lpm)	1.5	1.5
Allowable (.02 x Sample Rate)	30	30
Check OK	OK	OK

Leakage Checks Pitot

Plugged Probe	Pre Test 3 H ₂ O static	Pre Test 0.4-0.5 H ₂ O velocity	Post Test 3 H ₂ O Static	Post Test 0.4-0.5 H ₂ O velocity
Vacuum (inches Hg.)	3	.5	3	.5
Check OK (no change after 15 sec.)	OK	OK	OK	OK

PRE-TEST SCALE AUDIT

Date: 2018-08-01 Manufacturer: Acahslor Model: manchester
 Project #: p I 20174 Run: 3 Tech: mm Reviewer: DP

Scale Type	Audit		Measured Weight
	Equipment #	Weight	
Platform	EM-090	4.4 lbs, Class F	4.4 lbs
Wood	EM 090	4.4 lbs, Class F	4.4 lbs
Analytical	EM 128	100 mg, Class S	100mg
Analytical	EM 129	200 g, Class S	200 g

LIMITS OF WEIGHT RANGES

ANALYTICAL SCALE: 50%-150% of dry filter weight, ± 0.1 mg
PLATFORM SCALE: 20%-80% of ideal test load weight, ± 0.1 lbs or 1%
WOOD SCALE: 20%-80% of ideal test load weight, ± 0.01 lbs or 1%

Date: 2018-08-01 Manufacturer: Heathstone Model: manchester
 Project #: PT 20174 Run: 3 Tech: MR Reviewer: SP

FOR TUNNELS < 12 in

 Barometric pressure (P_{bar}) 1010 (KPa.) Static pressure (P_q) 0.19 (inches w.c.)
 Inside diameter: Port A _____ Port B _____
 Tunnel cross sectional area: .1963Ft²
 Pitot tube type: Standard

Traverse Point	Position (inches)			Velocity Head Δ_p (inches H ₂ O)	Tunnel Temperature (°F)
	6 po	7 po	8 po		
A- Centroid	3.00	3.50	4	0.058	79.54
B - Centroid	3.00	3.50	4	0.057	79.64
A-1	0.40	0.50	0.50	0.048	79.54
A-2	1.50	1.75	2	0.050	79.48
A-3	4.50	5.25	6	0.068	79.58
A-4	5.60	6.5	7.5	0.049	79.58
B-1	0.40	0.50	0.50	0.048	79.64
B-2	1.50	1.75	2	0.067	79.57
B-3	4.50	5.25	6	0.053	79.58
B-4	5.60	6.5	7.5	0.048	79.58
AVERAGE					

$$v_s = K_p C_p (\sqrt{\Delta p})_{avg} \sqrt{\frac{T_s}{P_s M_s}}$$

Where,

 C_p = pitot tube coefficient, dimension less = 0.99 for standard pitot.

 Δ_p = manometer reading (inches H₂O)

 T_s = average absolute dilution tunnel temperature (°F + 460)

 P_s = absolute dilution tunnel gas pressure or $P_{bar} + P_{qg}$
 P_q = static pressure in H₂O

{ 13.6 }

 M_s = 28.56, wet molecular weight of stack gas (alternatively, it may be measured)

 K_p = 85.49 pitot tube constant, (conversion factor for English units)

 $(\Delta_p)_{avg}$ = average of the square roots of the velocity heads (Δ_p) measured at each traverse point.

CONTINUOUS ANALYZERS

 Date: 2018-08-01 Manufacturer: Hearthstone Model: Amarches 412
 Project #: PT 20174 Run: 3 Tech: MM Reviewer: DP

Pre-Test (Adjust and Record)

	ZERO		SPAN		CAL. (Record Only)	
	Actual	Should Be	Actual	Should Be	Actual	Should Be
CO	0	0	2986	3000	1007	1000
Tolerance CO		+/- 0.02		+/- 0.15		+/- 0.05
CO ₂	0	0	1297	1800	973	1800 1800 mm
Tolerance CO ₂		+/- 0.02		+/- 0.5		+/- 0.5
O ₂ informative CSA B415 calculated value	na	na	na	na	na	na

Post Test (Record Only)

	Zero	Span	Cal.	Zero Drift	Limit	Span Drift	Limit	Cal. Drift	Limit	OK?	Not OK*
CO	0	2990	1001	0	0.02	0.004	0.15	0.006	0.05	✓	
CO ₂	0	1292	973	0	0.02	0.05	0.5	0.008	0.5	✓	

Date: 2018-08-01 Manufacturer: Hearthstone Model: Manchester
 Project #: PI 20174 Run: 3 Tech: MM Reviewer: SP

RAW DRY GAS METER READINGS

	System 1	System 2	Blanck
Final (Liter)	744739, 49	698377, 62	411, 95
Initial (Liter)	743488, 75	697138, 35	320, 76

AMBIENT CONDITIONS

	Before	After
Barometer (kPa):	1010	1005
Dry Bulb (F):	81.68	88.52
Humidity (%):	47	46

Flow Meter

	Start	End
Flow meter reading	NA	NA

Flow Meter Verification

	Before	After
Flow meter Check (liters)	NA	NA
Scale Weight (Kg)	NA	NA

FUEL DATA

Date: 2018-08-01 Manufacturer: Hearthstone Model: manchester
 Project #: PI 20174 Run: 3 Tech: MM Reviewer: [Signature]

FUEL DESCRIPTION:

Type of wood:

PRE-TEST LOAD

Piece Size	Weight	Meter Moisture Content (% dry)*				
1 1/2 x 3 1/2 x 18 in.	1,298 lbs.	198	194	196	195	198
1 1/2 x 3 1/2 x 18 in.	1,282 lbs.	204	206	206	207	207
1 1/2 x 3 1/2 x 18 in.	1,304 lbs.	191	196	198	194	198
1 1/2 x 3 1/2 x 18 in.	1,296 lbs.	199	198	197	194	198
1 1/2 x 3 1/2 x 11 in.	1,086 lbs.	208	204	205	207	208
1 1/2 x 3 1/2 x 18 in.	1,620 lbs.	193	198	197	198	197
1 1/2 x 3 1/2 x 18 in.	1,806 lbs.	199	196	197	199	198
1 1/2 x 3 1/2 x 18 in.	1,850 lbs.	206	207	208	209	206
1 1/2 x 3 1/2 x 18 in.	1,808 lbs.	199	198	196	197	197
x x in.	lbs.					
1 1/2 x 3 1/2 x 18 in.	1,504 lbs.	208	209	206	208	204
1 1/2 x 3 1/2 x 18 in.	1,924 lbs.	209	201	200	200	210
1 1/2 x 3 1/2 x 18 in.	1,818 lbs.	203	206	209	201	206
1 1/2 x 3 1/2 x 18 in.	1,826 lbs.	203	209	206	204	204
1 1/2 x 3 1/2 x 11 in.	1,058 lbs.	213	216	214	213	218
1 1/2 x 3 1/2 x 11 in.	1,318 lbs.	214	219	213	218	214
1 1/2 x 3 1/2 x 11 in.	1,316 lbs.	219	216	214	213	218
1 1/2 x 3 1/2 x 11 in.	1,116 lbs.	220	221	223	219	214
1 1/2 x 3 1/2 x 11 in.	1,164 lbs.	218	214	218	219	214
x x in.	lbs.					
x x in.	lbs.					
x x in.	lbs.					
x x in.	lbs.					

 TEST LOAD WEIGHT: 2639 lbs

Date: 2018-07-31 Manufacturer: Healthstone Model: Mow Chester

Project #: PT 20174 Run: 3 Tech: MR Reviewer: DR

Pre-test Weight Record		SYSTEM 1 - 1 st hour					SYSTEM 1				
Date	Time	Probe & Housing Number	Front Filter Number	Back Filter Number	gaskets	Probe & Housing Number	Front Filter Number	Back Filter Number	gaskets	Blank	
2018-07-31	19:00	19 109.0916	734	735	1	31	736	737	4	740	
2018-08-01	9:00	109.0909 109.0909	01236	01255	34.5251	110.1290	01280	01224	34.5043	01255	
			01235	01256	34.5250	110.1289	01279	01225	34.5044	01256	

Post-test Weight Record		SYSTEM 1 - 1 st hour					SYSTEM 1				
Date	Time	Probe & Housing Number	Front Filter Number	Back Filter Number	gaskets	Probe & Housing Number	Front Filter Number	Back Filter Number	gaskets	Blank	
2018-08-01	16:00	19 109.0911	734	735	1	31	736	737	4	740	
2018-08-08	8:00	109.0909 109.0909	01229	01258	34.5288	110.1290	01281	01222	34.5078	01261	
2018-08-09	8:00	109.0909 109.0909	01225	01255	34.5270	110.1290	01277	01221	34.5058	01258	
			01225	01255	34.5270	110.1290	01277	01221	34.5058	01257	

Date: 2018-07-31

Manufacturer: Heathmont

Model: Manchester

Project #: PJ 20174 Run: 3

Tech: MR Reviewer: DL

SYSTEM 2					
Pre-test Weight Record	Probe & Housing Number	Front Filter Number	Back Filter Number	gaskets	
Date	Time	33	738	739	39
2018-07-31	19:00	109.3629	01266	01266	34 4531
2018-08-01	9:00	109.3628	01267	01265	34 4532

SYSTEM 2					
Post-test Weight Record	Probe & Housing Number	Front Filter Number	Back Filter Number	gaskets	
Date	Time	33	738	739	39
2018-08-01	16:00	109.3630	01267	01263	34 4572
2018-08-08	8:00	109.3628	01268	01261	34 4551
2018-08-09	8:00	109.3628	01268	01261	34.4551

Paramètres

Tous les facteurs de corrections et autres paramètres qui peuvent être modifiés par l'utilisateur du fichier sont regroupés ici.

Code verrouillage:

HEA

Description du test

Test standard	EPA
Run #	4
Date	02-08-2018
Technicien	M.M
Project #	P-20174

Description de l'unité

Manufacturier	HEARTHSTONE	
Modèle	MANCHESTER	
Combustion system	Cat	
Appliance type	WOODSTOVE	
Firebox volume	2,45	cu ft.
Appliance weight empty	N.A	lbs
Appliance weight full	N.A	lbs

Paramètres du test

Logging time	1	min
Manufacturer's rated heat output	N.A	BTU/h Donnée fournie par le manufacturier
Targeted category	1	
Targeted output	N.A	BTU/h
Cp steel	N.A	BTU/lb-°F

Échantillonnage

Blank sampling rate	0,20	cuft/min
Internal probe diameter	0,18	in.
Calibration Factor (DGM #1):	0,988	Dimensionless
Equipment number (DGM #1):	EM 178	
Calibration Factor (DGM #2):	0,991	Dimensionless
Equipment number (DGM #2):	EM 179	
Calibration Factor (DGM #3):	0,996	Dimensionless
Equipment number (DGM #3):	EM 070	Dimensionless

Tunnel

Targeted tunnel flow rate	300	scfm
Tunnel diameter	8	in.
Molecular weight	28,78	May be assumed to be 28,78 (EPA) Si B-415 = 29
Pitot tube type	Standard	
Pitot tube coefficient	0,99	Dimensionless

Project nu.	P-20174
Date	02-08-2018
Technicien	M.M

Fuel data

Fuel type	Dimension	
Fuel specie	D. Fir	
HHV	19810,0	kJ/kg
%C	48,7	
%H	6,9	
%O	43,9	
%Ash	0,5	
HHV	8519,2	Btu/lb
LHV	7451,0	Btu/lb

Default Fuel Values		
	D. Fir	Oak/Maple
HHV	19 810	19 887
%C	48,73	50
%H	6,87	6,6
%O	43,9	42,9
%Ash	0,5	0,5
HHV (Btu/lb)	8519	8552
LHV (Btu/lb)	7451	7480

	Start	End
Barometer (kPa):	100,8	100,9
Barometer (in.Hg):	29,766229	29,79575878
Dry Bulb (F):	79,7	87,44
Humidity (%):	62,3	48,6
Air velocity (ft/min)	44	42

DGM #1	Final:	26328,441	cuft
	Initial:	26300,332	cuft
DGM #2	Final:	24690,796	cuft
	Initial:	24663,082	cuft
DGM room			

	Final:	745538,410	Liter
	Initial:	744742,450	Liter
	Final:	699165,460	Liter
	Initial:	698380,700	Liter
	Final:	471,160	cuft
	Initial:	411,950	cuft

Numéro de la ligne dans "Raw data" à partir duquel les données du VRAI test commencent

233

Autres données à rentrer: dans preload data, load data, traverse et filter set weight

Project nu.	P-20174
Date	02-08-2018
Technicien	M.M

Tunnel Traverse Worksheet (for velocity calculations)

Static Pressure: 0,2 in. H2O
 Barometer: 29,900 in. Hg

Pour un tunnel de 12" et plus, prendre 6 lectures

	TUNNEL VELOCITY	TUNNEL TEMP	SQUARE ROOT
	In. wc	°F	
A center			0,0000
B center			0,0000
A1			0,0000
A2			0,0000
A3			0,0000
A4			0,0000
A5			0,0000
A6			0,0000
B1			0,0000
B2			0,0000
B3			0,0000
B4			0,0000
B5			0,0000
B6			0,0000
AVERAGE	#DIV/0!	#DIV/0!	0,0000

PITOT CONSTANT=
0,965

Pour un tunnel moins de 12", prendre 4 lectures

	TUNNEL VELOCITY	TUNNEL TEMP	SQUARE ROOT
	In. wc	°F	
A center	0,060	77,42	0,2449
B center	0,059	77,64	0,2429
A1	0,049	77,45	0,2214
A2	0,051	77,54	0,2258
A3	0,070	77,48	0,2646
A4	0,050	77,54	0,2236
B1	0,049	77,570	0,2214
B2	0,068	77,520	0,2608
B3	0,052	77,460	0,2280
B4	0,049	77,260	0,2214
AVERAGE	0,0557	77,4880	0,2355

Project nu.	P-20174
Date	02-08-2018
Technicien	M.M

Filter set weight

	System 1 (g) 1st hour				System 1 (g)				System 2 (g)				Ambient blank (g)	Date	Heure
	probe	front	back	gasket	probe	front	back	gasket	probe	front	back	gasket	Filter		
Number	6	742	743	5	12	744	834	40	41	835	836	41	837		
Before (1)															
Before (2)															
Before (3)															
Before (4)															
Before (5)	61,3754	0,1240	0,1259	35,5180	94,5415	0,1227	0,1256	35,1329	110,3645	0,1268	0,1252	33,3349	0,1282	2018-08-01	17:00
Before (6)	61,3755	0,1241	0,1260	35,5181	94,5415	0,1228	0,1257	35,1328	110,3646	0,1268	0,1252	33,3350	0,1282	2018-08-02	09:00
After (1)	61,3761	0,1246	0,1265	35,5205	94,5431	0,1228	0,1257	35,1352	110,3654	0,1272	0,1253	33,3398	0,1285	2018-08-02	15:00
After (2)	61,3758	0,1243	0,1261	35,5184	94,5416	0,1224	0,1256	35,1341	110,3651	0,1268	0,1251	33,3364	0,1283	2018-08-08	08:00
After (3)	61,3758	0,1243	0,1261	35,5184	94,5416	0,1224	0,1256	35,1341	110,3651	0,1269	0,1252	33,3364	0,1283	2018-08-09	08:00
After (4)															
After (5)															
After (6)	61,3758	0,1243	0,1261	35,5184	94,5416	0,1224	0,1256	35,1341	110,3651	0,1269	0,1252	33,3364	0,1283	2018-08-09	08:00
Difference	0,0003	0,0002	0,0001	0,0003	0,0001	-0,0004	-0,0001	0,0013	0,0005	0,0001	0,0000	0,0014	0,0001		
Total (mg)		0,9				1,8				2			0,1		
Total ajusté (mg)		0,80				1,70				1,90					

Project nu.	P-20174
Date	02-08-2018
Technicien	M.M

SFBA EPA EMISSION RESULTS

RESULTS

Average emission rate: 1,4 g/hr
 Burn Rate : 2,416 Dry kg/hr

Test Duration: 155 min

PRESSURE FACTOR: DGM 1 0,97459
 DGM 2 0,97689
 DGM 3 0,99535

BAROMETRIC PRESSURE
 Average: 29,780994 in Hg
 Start: 29,766229 in Hg
 End: 29,795759 in Hg

TEMPERATURE FACTORS DGM 1 0,96753
 DGM 2 0,96774
 DGM 3 0,96869

DGM CONTROLLER VALUES
 DGM 1 Final: 26328,441 Cuft
 Initial: 26300,332 Cuft

VOLUMES SAMPLED DGM 1 26,200 Scft
 DGM 2 25,974 Scft
 DGM 3 56,847 Scft

DGM 2 Final: 24690,796 Cuft
 Initial: 24663,082 Cuft

DGM #3 Final: 471,160 Cuft
 Initial: 411,950 Cuft

TOTAL TUNNEL VOLUME : 49579

TEMPERATURES
 DGM 1 545,721 °R
 DGM 2 545,599 °R

SAMPLE RATIOS
 Sample Train 1: 1892,341
 Sample Train 2: 1908,745

CALIBRATION FACTORS
 DGM 1 0,9885
 DGM 2 0,9914
 DGM #3 0,9958

Paticulate concentration
 Sample Train 1 **0,000069** g/dscf
 Sample Train 2 **0,000077** g/dscf
 Room **0,000002** g/dscf

TUNNEL FLOW RATE: 319,862 Dscfm

TOTAL EMISSIONS
 Sample Train 1 **3,32** g
 Sample Train 2 **3,73** g

PARTICULATE CATCH
 Total Sample Train 1: 1,80 mg
 Total Sample Train 2: 2,00 mg
 Total Sample Train 1 1st hour: 0,90 mg

EMISSION RATES
 Sample Train 1 **1,28** g/hr
 Sample Train 2 **1,44** g/hr

1st hour emission rate **1,70** g/hr

DEVIATION: 5,83%

Cs Train 1 Train 2
 6,87E-05 7,69988E-05

Elapsed Time min	Raw data row	Weight Remaining lbs	CO %	CO ₂	O ₂ %	Flue Gas %	Room Temp °F	Tunnel Dry Bulb °F	Unit					Catalyst Down °F	Reading cuft/min	Inlet T °F	Outlet T °F	Temp °F	Reading cuft/min	Inlet T °F	Outlet T °F	Temp °F
									Unit Top °F	Unit Back °F	Unit R.Side °F	Unit L.Side °F	Unit Bottom °F									
0.00	233.00	16.5	0.1	2.9	0.0	371.6	83.4	113.5	378.2	286.1	528.2	358.6	232.8	632.1	0.17	84.73	84.20	84.11	0.17	84.35	83.76	84.08
1.0	234.0	16.3	0.0	5.2	0.0	385.4	83.2	107.4	374.3	284.3	526.5	356.1	233.7	727.0	0.17	84.81	84.19	84.02	0.16	84.45	83.79	83.98
2.0	235.0	16.1	0.0	8.6	0.0	413.3	83.3	108.2	377.6	285.4	524.3	353.6	233.9	845.1	0.17	84.84	84.19	83.67	0.16	84.53	83.83	83.24
3.0	236.0	15.9	0.1	10.8	0.0	444.1	83.0	110.1	387.0	286.6	521.2	350.3	233.5	972.7	0.17	84.89	84.20	83.67	0.16	84.55	83.85	82.73
4.0	237.0	15.7	0.2	11.4	0.0	467.7	83.1	110.9	398.7	295.4	517.3	347.5	234.0	1031.0	0.17	84.87	84.18	83.13	0.16	84.57	83.87	82.39
5.0	238.0	15.4	0.6	12.0	0.0	482.5	83.1	111.9	410.4	301.4	513.2	345.0	234.2	1068.4	0.17	84.87	84.20	82.87	0.16	84.58	83.90	82.13
6.0	239.0	15.2	0.3	11.5	0.0	491.0	83.1	113.0	420.3	306.6	508.5	342.4	234.3	1080.4	0.17	84.91	84.22	82.69	0.16	84.63	83.92	82.01
7.0	240.0	15.0	0.5	12.0	0.0	499.0	83.3	113.6	431.3	311.5	503.9	340.3	234.8	1086.5	0.17	84.92	84.23	82.54	0.17	84.65	83.94	81.92
8.0	241.0	14.7	0.9	12.2	0.0	507.8	83.6	114.9	443.6	316.4	500.0	338.4	235.8	1110.9	0.17	84.99	84.25	82.45	0.17	84.71	83.98	81.89
9.0	242.0	14.5	1.2	12.4	0.0	515.3	83.7	115.7	456.9	321.1	495.8	336.7	235.7	1111.7	0.17	85.04	84.30	82.36	0.16	84.78	84.02	81.86
10.0	243.0	14.2	1.2	12.4	0.0	525.3	83.5	115.6	468.3	325.0	491.9	335.3	235.5	1115.9	0.17	85.10	84.31	82.27	0.16	84.84	84.08	81.86
11.0	244.0	14.0	1.2	12.5	0.0	526.0	83.5	117.1	479.4	329.2	488.3	334.3	235.7	1130.2	0.17	85.10	84.34	82.21	0.16	84.87	84.10	81.86
12.0	245.0	13.7	1.0	12.5	0.0	529.9	83.7	116.9	489.5	333.5	485.0	332.7	236.2	1146.0	0.17	85.17	84.39	82.15	0.16	84.94	84.15	81.89
13.0	246.0	13.5	1.0	12.5	0.0	534.2	83.9	117.6	498.1	337.6	482.1	332.7	236.1	1151.9	0.17	85.22	84.41	82.13	0.16	84.98	84.19	81.93
14.0	247.0	13.2	0.9	12.4	0.0	538.0	84.1	118.0	507.3	341.4	479.8	332.4	236.2	1155.0	0.17	85.28	84.46	82.09	0.16	85.03	84.23	81.97
15.0	248.0	13.0	0.6	12.5	0.0	538.8	84.1	118.6	514.7	345.0	477.7	332.0	236.3	1157.3	0.17	85.39	84.51	82.08	0.16	85.14	84.28	82.03
16.0	249.0	12.7	0.6	12.4	0.0	541.6	84.6	120.0	520.6	348.0	475.7	331.8	236.2	1158.6	0.17	85.54	84.56	82.09	0.17	85.25	84.36	82.07
17.0	250.0	12.5	0.5	12.3	0.0	542.1	84.6	119.0	525.8	350.4	473.8	332.0	235.6	1154.2	0.17	85.66	84.64	82.09	0.16	85.38	84.44	82.14
18.0	251.0	12.3	0.5	12.4	0.0	542.8	84.6	119.5	530.1	353.2	472.6	332.1	235.9	1156.1	0.17	85.85	84.69	82.12	0.17	85.52	84.51	82.18
19.0	252.0	12.1	0.4	12.4	0.0	543.4	84.9	119.6	534.4	355.5	471.1	332.5	235.1	1154.7	0.17	85.96	84.74	82.14	0.16	85.63	84.59	82.24
20.0	253.0	11.8	0.4	12.4	0.0	544.3	85.0	120.1	538.1	357.4	469.7	332.8	235.1	1155.3	0.17	86.00	84.83	82.20	0.17	85.71	84.67	82.35
21.0	254.0	11.6	0.4	12.5	0.0	544.3	84.4	119.9	542.1	359.3	468.6	333.3	234.5	1153.8	0.17	85.98	84.87	82.22	0.16	85.76	84.74	82.37
22.0	255.0	11.4	0.5	12.5	0.0	544.3	84.7	120.3	545.6	360.8	468.1	334.1	234.1	1154.9	0.17	86.01	84.93	82.25	0.16	85.82	84.80	82.43
23.0	256.0	11.2	0.5	12.5	0.0	543.8	84.3	119.5	549.3	362.8	468.2	335.0	233.5	1154.4	0.17	85.93	84.95	82.28	0.16	85.78	84.85	82.49
24.0	257.0	11.0	0.5	12.5	0.0	544.8	84.9	119.9	552.4	364.3	467.2	335.6	234.2	1155.1	0.17	85.96	84.97	82.29	0.16	85.79	84.88	82.55
25.0	258.0	10.8	0.4	12.4	0.0	545.0	84.2	119.7	554.7	365.9	466.7	336.6	232.2	1152.9	0.17	86.02	85.03	82.33	0.16	85.85	84.92	82.59
26.0	259.0	10.6	0.4	12.3	0.0	545.0	85.0	119.8	557.0	367.0	466.6	337.7	231.9	1152.8	0.17	86.11	85.09	82.37	0.16	85.91	84.98	82.66
27.0	260.0	10.4	0.3	12.3	0.0	545.0	85.2	118.9	558.5	368.3	466.6	338.8	231.6	1151.8	0.17	86.22	85.12	82.45	0.16	86.01	85.05	82.76
28.0	261.0	10.2	0.3	12.3	0.0	544.8	85.1	118.5	560.0	369.7	466.7	339.6	230.7	1156.6	0.17	86.19	85.15	82.45	0.16	86.00	85.07	82.80
29.0	262.0	10.0	0.3	12.3	0.0	544.6	85.0	118.0	560.9	370.6	466.5	340.7	229.4	1158.1	0.17	86.21	85.17	82.48	0.17	86.02	85.10	82.86
30.0	263.0	9.8	0.4	12.4	0.0	544.9	84.9	119.3	562.9	371.6	467.1	341.4	229.4	1154.8	0.17	86.21	85.17	82.52	0.16	85.99	85.09	82.93
31.0	264.0	9.6	0.4	12.4	0.0	544.7	84.7	118.7	564.9	372.7	467.4	342.2	229.2	1156.8	0.17	86.22	85.19	82.53	0.16	86.02	85.10	82.97
32.0	265.0	9.4	0.4	12.5	0.0	545.2	84.9	119.4	566.6	373.9	468.3	343.1	228.8	1157.0	0.17	86.25	85.21	82.57	0.17	86.06	85.14	83.03
33.0	265.0	9.2	0.5	12.5	0.0	545.9	85.1	119.5	569.1	374.9	468.1	343.0	228.7	1156.8	0.17	86.28	85.22	82.57	0.17	86.05	85.15	83.09
34.0	267.0	9.0	0.5	12.5	0.0	546.2	85.3	118.9	569.6	376.4	469.7	345.1	227.7	1165.2	0.17	86.27	85.26	82.62	0.17	86.06	85.15	83.15
35.0	268.0	8.8	0.6	12.6	0.0	546.5	85.1	118.4	571.2	377.5	470.5	346.5	227.0	1168.9	0.17	86.29	85.29	82.69	0.16	86.05	85.15	83.22
36.0	269.0	8.6	0.6	12.6	0.0	547.1	85.4	119.3	573.2	378.5	471.7	347.7	227.1	1169.7	0.17	86.27	85.30	82.70	0.16	86.05	85.16	83.26
37.0	270.0	8.4	0.6	12.6	0.0	547.7	85.4	119.5	575.0	379.6	473.2	348.7	226.0	1170.8	0.17	86.25	85.30	82.71	0.16	86.07	85.19	83.32
38.0	271.0	8.2	0.6	12.6	0.0	548.8	85.4	118.9	576.6	380.9	474.2	349.4	225.8	1170.3	0.17	86.24	85.34	82.75	0.16	86.09	85.22	83.35
39.0	272.0	8.0	0.6	12.6	0.0	548.7	85.5	118.5	577.8	381.4	475.3	350.3	224.4	1166.5	0.17	86.32	85.37	82.79	0.16	86.13	85.25	83.40
40.0	273.0	7.8	0.6	12.7	0.0	548.6	85.0	118.2	579.4	382.1	476.5	351.3	223.7	1167.8	0.17	86.31	85.39	82.82	0.16	86.13	85.25	83.46
41.0	274.0	7.6	0.6	12.6	0.0	548.4	85.0	118.3	581.0	382.9	478.1	352.3	222.9	1166.4	0.17	86.26	85.38	82.87	0.17	86.09	85.27	83.50
42.0	275.0	7.4	0.7	12.7	0.0	548.5	85.2	119.0	582.4	383.8	479.6	353.2	222.2	1166.7	0.17	86.22	85.40	82.90	0.16	86.07	85.28	83.55
43.0	276.0	7.3	0.6	12.7	0.0	549.2	85.6	118.6	583.5	384.7	481.1	354.3	221.9	1165.1	0.17	86.24	85.42	82.92	0.16	86.05	85.29	83.60
44.0	277.0	7.1	0.7	12.6	0.0	548.9	84.9	118.9	584.4	385.2	482.4	355.8	221.8	1164.8	0.17	86.28	85.43	82.94	0.16	86.04	85.28	83.64
45.0	278.0	6.9	0.7	12.5	0.0	547.9	85.2	118.0	585.6	385.5	483.8	356.8	221.8	1159.8	0.17	86.26	85.43	83.00	0.16	86.07	85.29	83.69
46.0	279.0	6.7	0.7	12.5	0.0	546.6	85.4	118.6	586.4	385.9	486.2	358.3	221.6	1163.7	0.17	86.29	85.43	83.01	0.16	86.10	85.30	83.71
47.0	280.0	6.6	0.7	12.5	0.0	547.2	85.4	119.0	587.0	386.5	488.0	359.6	220.7	1161.2	0.17	86.18	85.45	83.04	0.16	86.03	85.33	83.75
48.0	281.0	6.4	0.5	12.4	0.0	545.6	85.6	118.5	586.6	386.2	490.0	361.5	220.2	1148.0	0.17	86.14	85.43	83.04	0.17	86.01	85.34	83.77
49.0	282.0	6.2	0.5	12.2	0.0	543.8	85.7	118.3	586.5	385.9	492.0	363.4	220.1	1132.4	0.17	86.23	85.44	83.05	0.16	86.05	85.34	83.77
50.0	283.0	6.1	0.4	12.2	0.0	541.6	86.0	118.5	586.0	385.7	493.5	364.8	220.1	1118.9	0.17	86.32	85.50	83.12	0.17	86.14	85.40	83.82
51.0	284.0	5.9	0.3	12.1	0.0	538.9	86.0	118.2	585.1	384.7	495.8	366.4	219.4	1101.6	0.17	86.27	85.52	83.11	0.17	86.13	85.44	83.82
52.0	285.0	5.8	0.2	11.9	0.0	536.2	85.7	117.7	583.9	383.9	497.2	367.1	218.0	1085.8	0.17	86.22	85.54	83.14	0.16	86.14		

90.0	323.0	2,2	0,0	7,5	0,0	415,1	85,6	105,3	457,2	324,4	557,3	385,5	218,4	807,4	0,17	86,04	85,49	82,62	0,16	85,88	85,40	85,37
91.0	324.0	2,1	0,0	7,2	0,0	412,9	85,3	104,8	452,6	323,0	556,8	383,9	218,4	807,7	0,17	85,95	85,50	82,58	0,16	85,84	85,38	85,32
92.0	325.0	2,1	0,0	7,2	0,0	410,7	85,4	104,3	448,2	321,5	555,9	382,4	218,7	806,7	0,17	85,87	85,49	82,55	0,16	85,77	85,37	85,28
93.0	326.0	2,0	0,0	7,2	0,0	407,8	85,0	104,5	443,8	319,4	555,9	381,0	219,1	803,7	0,17	85,79	85,46	82,51	0,16	85,70	85,33	85,24
94.0	327.0	2,0	0,0	7,3	0,0	405,6	84,9	105,0	439,3	317,5	556,2	379,9	218,8	800,8	0,17	85,75	85,44	82,46	0,16	85,66	85,30	85,23
95.0	328.0	2,0	0,0	7,3	0,0	403,6	85,2	104,2	434,8	315,7	556,0	377,5	219,4	798,9	0,17	85,72	85,42	82,44	0,16	85,64	85,29	85,21
96.0	329.0	1,9	0,0	7,3	0,0	402,3	85,6	103,2	430,7	314,3	555,2	375,9	219,5	795,2	0,17	85,72	85,44	82,40	0,16	85,63	85,29	85,17
97.0	330.0	1,9	0,0	7,3	0,0	401,3	85,2	102,9	426,7	312,3	555,2	373,9	219,6	793,5	0,17	85,70	85,43	82,35	0,16	85,60	85,28	85,14
98.0	331.0	1,8	0,0	7,3	0,0	400,0	85,3	102,8	423,0	310,6	554,3	372,3	218,0	792,8	0,17	85,66	85,42	82,32	0,16	85,57	85,28	85,07
99.0	332.0	1,8	0,0	7,3	0,0	399,3	85,3	102,6	419,7	308,7	554,1	370,4	219,1	791,2	0,17	85,64	85,44	82,25	0,16	85,53	85,26	85,04
100.0	333.0	1,8	0,0	7,3	0,0	398,3	85,1	102,9	416,5	307,2	553,5	368,3	219,4	792,3	0,17	85,63	85,42	82,24	0,16	85,57	85,26	85,01
101.0	334.0	1,7	0,0	7,3	0,0	397,4	84,3	102,9	413,2	305,4	552,8	366,6	219,8	792,7	0,17	85,62	85,45	82,19	0,16	85,55	85,26	84,99
102.0	335.0	1,7	0,0	7,3	0,0	395,9	84,8	102,9	410,3	303,8	552,6	364,7	219,8	793,8	0,17	85,65	85,45	82,17	0,16	85,57	85,26	84,98
103.0	336.0	1,7	0,0	7,3	0,0	395,1	85,3	103,3	407,2	302,1	552,0	363,0	219,1	792,8	0,17	85,56	85,42	82,10	0,16	85,50	85,27	84,94
104.0	337.0	1,6	0,0	7,3	0,0	394,8	84,2	102,6	404,2	300,7	551,4	361,1	219,6	792,4	0,17	85,48	85,40	82,07	0,16	85,46	85,28	84,89
105.0	338.0	1,6	0,0	7,2	0,0	394,1	84,5	102,8	401,3	299,1	550,8	359,3	219,7	792,5	0,17	85,30	85,40	82,01	0,16	85,36	85,28	84,88
106.0	339.0	1,5	0,0	7,2	0,0	393,0	84,2	102,5	398,3	297,7	549,8	357,9	220,4	793,2	0,17	85,26	85,39	81,97	0,16	85,35	85,29	84,86
107.0	340.0	1,5	0,0	7,0	0,0	392,2	84,5	102,2	395,1	296,3	549,2	356,1	219,7	795,1	0,17	85,23	85,40	81,91	0,16	85,31	85,30	84,83
108.0	341.0	1,5	0,0	6,9	0,0	392,0	84,5	102,3	391,9	295,1	548,6	354,6	221,4	798,3	0,17	85,24	85,39	81,86	0,16	85,31	85,29	84,79
109.0	342.0	1,4	0,0	6,9	0,0	391,9	84,6	102,5	389,1	294,1	547,7	352,7	221,5	801,5	0,17	85,30	85,41	81,86	0,16	85,31	85,30	84,77
110.0	343.0	1,4	0,0	7,0	0,0	391,3	84,6	102,9	386,7	293,0	546,4	351,6	220,8	802,4	0,17	85,37	85,43	81,81	0,16	85,36	85,30	84,76
111.0	344.0	1,4	0,0	7,0	0,0	390,8	84,4	102,9	384,4	291,7	545,3	350,1	221,4	802,5	0,17	85,43	85,46	81,78	0,16	85,41	85,33	84,76
112.0	345.0	1,3	0,0	7,0	0,0	391,0	84,8	103,5	382,0	290,4	544,2	348,9	223,0	804,7	0,17	85,49	85,47	81,75	0,16	85,46	85,34	84,76
113.0	346.0	1,3	0,0	7,1	0,0	390,9	85,2	102,9	380,0	289,3	543,0	347,6	222,8	806,7	0,17	85,47	85,48	81,73	0,16	85,47	85,37	84,76
114.0	347.0	1,3	0,0	7,1	0,0	390,7	85,4	102,8	378,0	288,1	542,0	346,6	222,4	806,2	0,17	85,53	85,52	81,71	0,16	85,53	85,39	84,73
115.0	348.0	1,2	0,0	7,1	0,0	390,9	85,2	102,9	376,4	287,4	540,8	344,8	223,1	806,9	0,17	85,60	85,55	81,69	0,16	85,59	85,41	84,72
116.0	349.0	1,2	0,0	7,0	0,0	391,0	84,8	103,2	374,4	286,5	539,3	343,9	222,1	808,6	0,17	85,65	85,55	81,69	0,16	85,59	85,41	84,74
117.0	350.0	1,2	0,0	6,9	0,0	389,8	85,2	103,3	372,3	285,2	538,2	343,0	223,7	807,0	0,17	85,67	85,57	81,69	0,16	85,61	85,40	84,75
118.0	351.0	1,1	0,0	6,7	0,0	388,9	84,9	103,1	370,0	284,4	536,7	341,3	224,6	804,5	0,17	85,74	85,60	81,65	0,16	85,70	85,44	84,74
119.0	352.0	1,1	0,0	6,7	0,0	388,4	85,2	103,3	368,1	283,5	535,3	339,9	224,4	805,1	0,17	85,76	85,62	81,64	0,16	85,72	85,47	84,76
120.0	353.0	1,1	0,0	6,7	0,0	387,8	85,0	103,4	366,1	282,7	533,5	338,8	223,9	806,1	0,17	85,79	85,65	81,64	0,16	85,77	85,49	84,75
121.0	354.0	1,0	0,0	6,5	0,0	386,8	84,6	103,0	363,8	281,7	532,6	337,9	224,9	802,0	0,17	85,79	85,63	81,63	0,16	85,77	85,50	84,73
122.0	355.0	1,0	0,0	6,4	0,0	384,7	85,4	103,4	361,5	281,0	531,2	336,5	224,3	792,4	0,17	85,81	85,66	81,64	0,16	85,81	85,54	84,75
123.0	356.0	1,0	0,0	6,4	0,0	382,9	85,2	103,2	359,1	279,7	529,4	335,5	224,3	789,5	0,17	85,88	85,69	81,63	0,16	85,88	85,55	84,75
124.0	357.0	0,9	0,0	6,4	0,0	382,1	84,9	102,9	357,3	278,5	527,8	334,0	224,8	789,3	0,17	85,90	85,72	81,62	0,16	85,90	85,61	84,77
125.0	358.0	0,9	0,0	6,4	0,0	381,8	84,9	103,3	355,0	277,5	525,7	332,8	223,8	789,3	0,17	85,92	85,74	81,62	0,16	85,93	85,64	84,77
126.0	359.0	0,9	0,0	6,4	0,0	380,9	85,1	103,2	353,1	276,3	523,7	331,8	224,0	788,3	0,17	85,97	85,77	81,61	0,16	85,99	85,67	84,79
127.0	360.0	0,8	0,0	6,4	0,0	379,7	84,8	103,2	351,3	275,2	521,8	330,5	224,8	788,0	0,17	86,05	85,79	81,62	0,16	86,05	85,68	84,75
128.0	361.0	0,8	0,0	6,4	0,0	379,2	85,3	103,1	349,3	274,5	519,4	329,5	222,7	787,0	0,17	86,02	85,82	81,59	0,16	86,05	85,72	84,78
129.0	362.0	0,8	0,0	6,3	0,0	378,8	84,8	103,3	347,3	273,3	517,8	328,8	225,0	786,2	0,17	86,02	85,82	81,61	0,16	86,05	85,73	84,77
130.0	363.0	0,7	0,0	6,2	0,0	379,1	85,2	103,4	345,6	272,6	515,6	327,3	223,5	787,7	0,17	86,08	85,88	81,59	0,16	86,11	85,77	84,80
131.0	364.0	0,7	0,0	6,3	0,0	379,4	85,5	103,6	344,2	271,7	513,5	326,0	225,1	790,1	0,17	86,14	85,90	81,60	0,16	86,16	85,81	84,82
132.0	365.0	0,7	0,0	6,3	0,0	378,4	85,4	103,8	342,7	271,0	511,3	324,5	224,6	789,7	0,17	86,13	85,93	81,59	0,16	86,18	85,86	84,84
133.0	366.0	0,7	0,0	6,4	0,0	377,9	85,4	104,0	341,0	269,8	509,3	323,8	225,7	788,5	0,17	86,24	85,95	81,58	0,16	86,25	85,89	84,86
134.0	367.0	0,6	0,0	6,4	0,0	378,0	85,7	104,0	339,7	269,2	507,2	322,7	223,8	787,8	0,17	86,33	86,00	81,59	0,16	86,32	85,94	84,89
135.0	368.0	0,6	0,0	6,4	0,0	377,9	85,4	104,0	338,2	268,6	505,2	321,8	225,5	786,4	0,17	86,41	86,04	81,62	0,16	86,42	86,00	84,93
136.0	369.0	0,6	0,0	6,2	0,0	377,6	85,5	104,0	337,0	268,0	503,0	321,1	224,7	785,3	0,17	86,48	86,08	81,61	0,16	86,49	86,02	84,94
137.0	370.0	0,5	0,0	6,2	0,0	377,7	85,7	104,0	335,5	267,2	501,1	319,9	223,9	785,3	0,17	86,49	86,13	81,61	0,16	86,53	86,05	84,96
138.0	371.0	0,5	0,0	6,2	0,0	377,3	85,6	104,0	334,1	266,5	499,0	319,1	224,7	784,8	0,17	86,49	86,13	81,63	0,16	86,51	86,05	84,98
139.0	372.0	0,5	0,0	6,2	0,0	376,7	85,6	104,1	332,7	265,8	497,0	318,0	224,3	784,8	0,17	86,58	86,18	81,63	0,16	86,59	86,08	84,99
140.0	373.0	0,4	0,0	6,1	0,0	376,1	85,0	104,2	331,2	264,6	495,0	317,0	224,5	783,8	0,17	86,64	86,22	81,66	0,16	86,64	86,14	85,02
141.0	374.0	0,4	0,0	6,1	0,0	375,3	85,3	104,3	329,9	263,9	493,0	316,3	225,4	782,2	0,17	86,63	86,25	81,65	0,16	86,69	86,18	85,03
142.0	375.0	0,4	0,0	6,1	0,0	375,4	85,7	104,5	328,7	263,5	491,1	315,0	224,2	781,2	0,17	86,70	86,29	81,67	0,16	86,74	86,22	85,08
143.0	376.0	0,4	0,0	6,1	0,0	374,8	85,8	104,0	327,4	262,6	489,4	314,4	225,2	783,3	0,17	86,74	86,30	81,68	0,16	86,75	86,22	85,09
144.0	377.0	0,3	0,0	6,1	0,0	375,3	84,4	104,0	325,7	261,9	487,7	313,0	224,8	784,1	0,17	86,73	86,33	81,69	0,16	86,		

Manufacturer: HEARTHSTONE
 Model: MANCHESTER

Run: 4
 Project #: P-20174
 Test Duration: 155 min

	HHV	LHV
Eff	72,76%	78,64%
Comb Eff	97,84%	97,84%
HT Eff	74,37%	80,38%
Output	34 828	kJ/h
Burn Rate	2,42	kg/h
Grams CO	204	g
Input	47 864	kJ/h
MC wet	16,75	

Note: In the "Input data", "Calc. % O₂", "Fuel Properties", and "Mass Balance" columns, [e], [d], [g], [a], [b], [c], [h], [u], [w], [j], and [k] refer to their respective variables in Clauses 13.7.3

Ultimate CO₂
 CO_{2-ut} 19,64
 F_o
 1,062

	Air Fuel Ratio (A/F)	
Overall Heating Efficiency:	72,76%	Dry Molecular Weight (M _d) 29,92
Combustion Efficiency:	97,84%	Dry Moles Exhaust Gas (N _g): 412,32
Heat Transfer Efficiency:	74,37%	Air Fuel Ratio (A/F) 11,83

Heat Output:	33 038 Btu/h	34 828 kJ/h
Heat Input:	45 405 Btu/h	47 864 kJ/h
Burn Duration:	2,58 h	
Burn Rate:	5,33 lb/h	2,416 kg/h
Stack Temp:	454,9 Deg. F	234,9 Deg. C

PRE / POST CHECKS

Date: 2018-08-02

Manufacturer: Hearthstone

Model: Manchester

Project #: PT 20174

Run: 4

Tech: MM

Reviewer: id

Moisture Meter Calibration Check:

Equipment #	Time	12%	22%
EM-191	7:00	ok	ok

Pre-Test

Post-Test

Facility Conditions:

Air Velocity from less than 2 feet

<u>44</u> (max50 Fpm)	<u>42</u> (max50 Fpm)
-----------------------	-----------------------

Smoke Capture Check.....

<u>ok</u>	<u>ok</u>
-----------	-----------

Picture.....

4 sides <u>ok</u>	<u>ok</u>
-------------------	-----------

Wood Heater Conditions:

Date Wood Heater Stack Cleaned.....

<u>2018-07-30</u>

Date Dilution Tunnel Cleaned.....

<u>2018-07-30</u>

Induced Draft Check (max 0.005 H2O).....

<u>ok</u>

Traverse before ignition.....

<u>ok</u>

Flow Rate 140 cfm ±10%.....

<u>ok</u>

Temperature System:

Ambient (65°-90°F).....

<u>ok</u> °F

Wood Heater Surface (±125°F).....

<u>ok</u> °F

Proportional Checks:

Thermocouple check.....

<u>ok</u>

Pitot Clean.....

<u>ok</u>

Pitot verification.....

<u>ok</u>

Sampling Train ID Numbers:

Probe.....

Train 1 st hour	Train 1	Train 2
<u>06</u>	<u>12</u>	<u>41</u>
<u>742</u>	<u>744</u>	<u>835</u>
<u>743</u>	<u>834</u>	<u>836</u>
<u>11</u>	<u>11</u>	<u>12</u>
<u>ok</u>	<u>ok</u>	<u>ok</u>

Filter Front.....

Filter Back.....

Filter Thermocouple.....

Filter (<90°F).....

SAMPLING EQUIPMENT CHECK OUT

Date: 2018-08-02 Manufacturer: Hearthstone Model: Manchester
 Project #: PT 20174 Run: 4 Tech: MR Reviewer: [Signature]

Leakage Checks Tunnel Samplers

	System 1 st hour		System 1		System 2	
	Pre-Test ASTM (-15) CSA B415 (-5)	Post-Test (max test)	Pre-Test ASTM (-15) CSA B415 (-5)	Post-Test (Max test)	Pre-Test ASTM (-15) CSA B415 (-5)	Post-Test (Max test)
Unplugged Flow Rate = .25cfm						
Vacuum (inches Hg.)	-15	-15	-15	-15	-15	-15
Final 1minute DGM (Liter)	744741.51	745539.46	744741.86	745539	698380.00	699166.51
Initial 1minute DGM (Liter)	744741.41	745539.45	744741.85	745539.50	698380.00	699166.50
Change © (Liter)	0.10	0.10	0.01	0.01	0	0.01
Allowable leakage .04 x Sample rate or 0.28Lpm CSA B415 (0.56)						
Check OK	ok	ok	ok	ok	ok	ok

Leakage Checks Flue Gas Sampler

Plugged Probe	Pre Test	Post Test
Vacuum (inches Hg.)	-5	-5
Rotometer Reading (mm/min.)	0	0
Flow Rate (lpm)	1.5	1.5
Allowable (.02 x Sample Rate)	30	30
Check OK	ok	ok

Leakage Checks Pitot

Plugged Probe	Pre Test 3 H ₂ O static	Pre Test 0.4-0.5 H ₂ O velocity	Post Test 3 H ₂ O Static	Post Test 0.4-0.5 H ₂ O velocity
Vacuum (inches Hg.)	3	.4	3	.4
Check OK (no change after 15 sec.)	ok	ok	ok	ok

PRE-TEST SCALE AUDIT

 Date: 2018-08-02

 Manufacturer: Healthstone

 Model: Manchester

 Project #: PI 20174

 Run: 4

 Tech: MR

 Reviewer: JS

Scale Type	Audit		Measured Weight
	Equipment #	Weight	
Platform	EM-090	4.4 lbs, Class F	4.4 lbs
Wood	EM-090	4.4 lbs, Class F	4.4 lbs
Analytical	EM-128	100 mg, Class S	100 mg
Analytical	EM-129	200 g, Class S	200 g

LIMITS OF WEIGHT RANGES

ANALYTICAL SCALE: 50%-150% of dry filter weight, ± 0.1 mg
PLATFORM SCALE: 20%-80% of ideal test load weight, ± 0.1 lbs or 1%
WOOD SCALE: 20%-80% of ideal test load weight, ± 0.01 lbs or 1%

Date: 2018-08-02 Manufacturer: Hearthstone Model: Manchester
 Project #: PI 26174 Run: 4 Tech: mm Reviewer: DP

FOR TUNNELS < 12 in

 Barometric pressure (P_{bar}) 100.8 (KPa.) Static pressure (P_q) 0.20 (inches w.c.)
 Inside diameter: Port A _____ Port B _____
 Tunnel cross sectional area: .1963Ft²
 Pitot tube type: Standard

Traverse Point	Position (inches)			Velocity Head Δ_p (inches H ₂ O)	Tunnel Temperature (°F)
	6 po	7 po	8 po		
A - Centroid	3.00	3.50	4	0.060	77.42
B - Centroid	3.00	3.50	4	0.059	77.64
A-1	0.40	0.50	0.50	0.049	77.45
A-2	1.50	1.75	2	0.051	77.54
A-3	4.50	5.25	6	0.070	77.48
A-4	5.60	6.5	7.5	0.050	77.54
B-1	0.40	0.50	0.50	0.049	77.53
B-2	1.50	1.75	2	0.068	77.52
B-3	4.50	5.25	6	0.052	77.46
B-4	5.60	6.5	7.5	0.049	77.26
AVERAGE					

$$v_s = K_p C_p (\sqrt{\Delta_p})_{avg} \sqrt{\frac{(T_s)_{avg}}{P_s M_s}}$$

Where,

 C_p = pitot tube coefficient, dimension less = 0.99 for standard pitot.

 Δ_p = manometer reading (inches H₂O)

 T_s = average absolute dilution tunnel temperature (°F + 460)

 P_s = absolute dilution tunnel gas pressure or $P_{bar} + P_{qg}$
 P_q = static pressure $\frac{\text{in. H}_2\text{O}}{\{ 13.6 \}}$
 M_s = 28.56, wet molecular weight of stack gas (alternatively, it may be measured)

 K_p = 85.49 pitot tube constant, (conversion factor for English units)

 $(\Delta_p)_{avg}$ = average of the square roots of the velocity heads (Δ_p) measured at each traverse point.

Date: 2018-08-02 Manufacturer: ~~Ametek~~ Model: manchester
 Project #: PT 20174 Run: 4 Tech: MM Reviewer: JP

Pre-Test (Adjust and Record)

	ZERO		SPAN		CAL. (Record Only)	
	Actual	Should Be	Actual	Should Be	Actual	Should Be
CO	0	0	2,974	3,000	1,005	1,000
Tolerance CO		+/- 0.02		+/- 0.15		+/- 0.05
CO ₂	0	0	17,94	18,00	9,73	10,00
Tolerance CO ₂		+/- 0.02		+/- 0.5		+/- 0.5
O ₂ informative CSA B415 calculated value	na	na	na	na	na	na

Post Test (Record Only)

	Zero	Span	Cal.	Zero Drift	Limit	Span Drift	Limit	Cal. Drift	Limit	OK?	Not OK*
CO	0	2,985	1,005	0	0.02	0,005	0.15	0,009	0.05	✓	
CO ₂	0	17,95	9,71	0	0.02	0,03	0.5	0,04	0.5	✓	

TEST DATA LOG

Date: 2018-08-02 Manufacturer: Hearthstone Model: Manchester
 Project #: PT 20174 Run: 4 Tech: MM Reviewer: DO

RAW DRY GAS METER READINGS

	System 1	System 2	Blank
Final (Liter)	745538.41	699165.46	471.16
Initial (Liter)	744792.95	698380.70	411.95

AMBIENT CONDITIONS

	Before	After
Barometer (kPa):	1008	1009
Dry Bulb (F):	79.70	87.44
Humidity (%):	63.3	48.6

Flow Meter

	Start	End
Flow meter reading	NA	NA

Flow Meter Verification

	Before	After
Flow meter Check (liters)	NA	NA
Scale Weight (Kg)	NA	NA

FUEL DATA

Date: 2018-08-02 Manufacturer: Hearthstone Model: manchester
 Project #: PT 20174 Run: 4 Tech: MM Reviewer: JD

FUEL DESCRIPTION:

Type of wood:

PRE-TEST LOAD

Piece Size	Weight	Meter Moisture Content (% dry)*						
1 1/2 x 3 1/2 x 18 in.	1598 lbs.	208	207	199	201	201		
1 1/2 x 3 1/2 x 18 in.	1854 lbs.	206	203	204	208	211		
1 1/2 x 3 1/2 x 18 in.	176 lbs.	199	193	197	196	195		
1 1/2 x 3 1/2 x 18 in.	2018 lbs.	203	204	206	208	204		
1 1/2 x 3 1/2 x 11 in.	1168 lbs.	207	208	206	204	205		
1 1/2 x 3 1/2 x 11 in.	0942 lbs.	211	213	219	213	214		
1 1/2 x 3 1/2 x 11 in.	1234 lbs.	191	196	196	195	195		
1 1/2 x 3 1/2 x 11 in.	097 lbs.	200	203	204	202	204		
1 1/2 x 3 1/2 x 11 in.	106 lbs.	193	196	196	195	193		
x x in.	lbs.							
1 1/2 x 3 1/2 x 18 in.	1722 lbs.	194	198	197	198	199		
1 1/2 x 3 1/2 x 18 in.	1834 lbs.	200	201	203	206	209		
1 1/2 x 3 1/2 x 18 in.	182 lbs.	203	208	206	208	209		
1 1/2 x 3 1/2 x 18 in.	1726 lbs.	199	193	194	196	193		
1 1/2 x 3 1/2 x 11 in.	1162 lbs.	200	204	206	208	209		
1 1/2 x 3 1/2 x 11 in.	1056 lbs.	196	193	192	191	191		
1 1/2 x 3 1/2 x 11 in.	1132 lbs.	200	203	208	203	209		
1 1/2 x 3 1/2 x 11 in.	1002 lbs.	200	204	203	202	206		
1 1/2 x 3 1/2 x 11 in.	1074 lbs.	206	203	203	209	204		
x x in.	lbs.							
x x in.	lbs.							
x x in.	lbs.							
x x in.	lbs.							

TEST LOAD WEIGHT: 2513 lbs

FUEL DATA

 Date: 2018-08-02 Manufacturer: Hearthstone Model: Manchester
 Project #: pt 20174 Run: 4 Tech: mm Reviewer: DO
FUEL DESCRIPTION:

Type of wood :

TEST LOAD

Piece Size	Weight	Meter Moisture Content (% dry)*				
1 1/2 x 3 1/2 x 2 1/4 in.	2.25 lbs.	191	192	193	192	192
1 1/2 x 3 1/2 x 2 1/4 in.	2.318 lbs.	218	219	220	217	219
3 1/2 x 3 1/2 x 2 1/4 in.	5.286 lbs.	20	20	20	199	193
3 1/2 x 3 1/2 x 2 1/4 in.	5.374 lbs.	20	206	204	200	191
1 1/2 x 3/4 x 5 in.	0.108 lbs.			191		
1 1/2 x 3/4 x 5 in.	0.116 lbs.			196		
1 1/2 x 3/4 x 5 in.	0.110 lbs.			194		
1 1/2 x 3/4 x 5 in.	0.104 lbs.			198		
1 1/2 x 3/4 x 5 in.	0.098 lbs.			199		
1 1/2 x 3/4 x 5 in.	0.112 lbs.			200		
1 1/2 x 3/4 x 5 in.	0.096 lbs.			20		
1 1/2 x 3/4 x 5 in.	0.112 lbs.			196		
1 1/2 x 3/4 x 5 in.	0.112 lbs.			195		
1 1/2 x 3/4 x 5 in.	0.114 lbs.			199		
1 1/2 x 3/4 x 5 in.	0.094 lbs.			200		
1 1/2 x 3/4 x 5 in.	0.110 lbs.			206		
x x in.	lbs.					
x x in.	lbs.					
x x in.	lbs.					
x x in.	lbs.					
x x in.	lbs.					
x x in.	lbs.					
x x in.	lbs.					
x x in.	lbs.					
x x in.	lbs.					
x x in.	lbs.					
x x in.	lbs.					
x x in.	lbs.					
x x in.	lbs.					

 TEST LOAD WEIGHT: 16.52 lbs Min 20%: 3.30 Max 25%: 4.13

North Carolina
Manufacturer: Manchester

Model: Manchester

Date: 2018-08-02
Project #: PI 20174 Run: 4
Tech: MM Reviewer: DS

Pre-test Weight Record		SYSTEM 1 - 1 st hour						SYSTEM 1						
Date	Time	Probe & Housing Number	Front Filter Number	Back Filter Number	gaskets	Probe & Housing Number	Front Filter Number	Back Filter Number	gaskets	Probe & Housing Number	Front Filter Number	Back Filter Number	gaskets	Blank
2018-08-02	17:00	06	742	743	5	12	744	834	40	837				
		G13754	01240	01259	35, 5180	94, 5415	01227	01256	35, 1329	01282				
2018-08-02	9:00	G13755	01241	01260	35, 5181	94, 5415	01228	01257	35, 1328	01282				

Post-test Weight Record		SYSTEM 1 - 1 st hour						SYSTEM 1						
Date	Time	Probe & Housing Number	Front Filter Number	Back Filter Number	gaskets	Probe & Housing Number	Front Filter Number	Back Filter Number	gaskets	Probe & Housing Number	Front Filter Number	Back Filter Number	gaskets	Blank
2018-08-02	15:00	06	742	743	5	12	744	834	40	837				
		G13761	01246	01265	35, 5205	94, 5431	01228	01257	35, 1352	01285				
2018-08-08	8:00	G13758	01243	01261	35, 5184	94, 5416	01224	01256	35, 1341	01283				
2018-08-09	8:00	G13758	01243	01261	35, 5184	94, 5416	01224	01256	35, 1341	01283				



DILUTION TUNNEL PARTICULATE SAMPLER DATA

Date: 2018-08-02 Project #: PT 20174 Run: 4 Manufacturer: Heathstone Model: Manchester
 Tech: MA Reviewer: TS

SYSTEM 2					
Pre-test Weight Record	Probe & Housing Number	Front Filter Number	Back Filter Number	gaskets	
Date	Time	41	835	836	41
2018-08-01	17:00	110 3645	0 1268	0 1252	33,3349
2018-08-01	9:00	110 3646	0 1268	0 1252	33,3350

SYSTEM 2					
Post-test Weight Record	Probe & Housing Number	Front Filter Number	Back Filter Number	gaskets	
Date	Time	41	835	836	41
2018-08-02	15:00	110 3654	0 1272	0 1253	33 3398
2018-08-09	8:00	110 3651	0 1268	0 1251	33 3364
2018-08-09	8:00	110 3651	0 1269	0 1252	33.3364

Paramètres

Tous les facteurs de corrections et autres paramètres qui peuvent être modifiés par l'utilisateur du fichier sont regroupés ici.

Code verrouillage:

HEA

Description du test

Test standard	EPA
Run #	5
Date	03-08-2018
Technicien	M.M
Project #	P-20174

Description de l'unité

Manufacturier	HEARTHSTONE	
Modèle	MANCHESTER	
Combustion system	Cat	
Appliance type	WOODSTOVE	
Firebox volume	2,45	cu ft.
Appliance weight empty	N.A	lbs
Appliance weight full	N.A	lbs

Paramètres du test

Logging time	1	min
Manufacturer's rated heat output	N.A	BTU/h Donnée fournie par le manufacturier
Targeted category	1	
Targeted output	N.A	BTU/h
Cp steel	N.A	BTU/lb-°F

Échantillonnage

Blank sampling rate	0,20	cuft/min
Internal probe diameter	0,18	in.
Calibration Factor (DGM #1):	0,988	Dimensionless
Equipment number (DGM #1):	EM 178	
Calibration Factor (DGM #2):	0,991	Dimensionless
Equipment number (DGM #2):	EM 179	
Calibration Factor (DGM #3):	0,996	Dimensionless
Equipment number (DGM #3):	EM 070	Dimensionless

Tunnel

Targeted tunnel flow rate	300	scfm
Tunnel diameter	8	in.
Molecular weight	28,78	May be assumed to be 28,78 (EPA) Si B-415 = 29
Pitot tube type	Standard	
Pitot tube coefficient	0,99	Dimensionless

Project nu.	P-20174
Date	03-08-2018
Technicien	M.M

Fuel data

Fuel type	Dimension
Fuel specie	D. Fir
HHV	19810,0 kJ/kg
%C	48,7
%H	6,9
%O	43,9
%Ash	0,5
HHV	8519,2 Btu/lb
LHV	7451,0 Btu/lb

Default Fuel Values		
	D. Fir	Oak/Maple
HHV	19 810	19 887
%C	48,73	50
%H	6,87	6,6
%O	43,9	42,9
%Ash	0,5	0,5
HHV (Btu/lb)	8519	8552
LHV (Btu/lb)	7451	7480

	Start	End
Barometer (kPa):	101,3	101
Barometer (in.Hg):	29,913879	29,82528877
Dry Bulb (F):	80,63	88,83
Humidity (%):	53,5	43,1
Air velocity (ft/min)	44	43

DGM #1	Final:	26394,769	cuft
	Initial:	26328,514	cuft
DGM #2	Final:	24755,847	cuft
	Initial:	24690,873	cuft
DGM room			

	Final:	747416,600	Liter
	Initial:	745540,490	Liter
	Final:	701007,520	Liter
	Initial:	699167,650	Liter
	Final:	610,060	cuft
	Initial:	471,160	cuft

Numéro de la ligne dans "Raw data" à partir duquel les données du VRAI test commencent

215

Autres données à rentrer: dans preload data, load data, traverse et filter set weight

Project nu.	P-20174
Date	03-08-2018
Technicien	M.M

Tunnel Traverse Worksheet (for velocity calculations)

Static Pressure: 0,2 in. H2O
 Barometer: 29,900 in. Hg

Pour un tunnel de 12" et plus, prendre 6 lectures

	TUNNEL VELOCITY	TUNNEL TEMP	SQUARE ROOT
	In. wc	°F	
A center			0,0000
B center			0,0000
A1			0,0000
A2			0,0000
A3			0,0000
A4			0,0000
A5			0,0000
A6			0,0000
B1			0,0000
B2			0,0000
B3			0,0000
B4			0,0000
B5			0,0000
B6			0,0000
AVERAGE	#DIV/0!	#DIV/0!	0,0000

PITOT CONSTANT=
0,969

Pour un tunnel moins de 12", prendre 4 lectures

	TUNNEL VELOCITY	TUNNEL TEMP	SQUARE ROOT
	In. wc	°F	
A center	0,058	78,5	0,2408
B center	0,057	78,69	0,2387
A1	0,047	78,54	0,2168
A2	0,050	78,53	0,2236
A3	0,069	78,53	0,2627
A4	0,048	78,59	0,2191
B1	0,049	78,540	0,2214
B2	0,067	78,540	0,2588
B3	0,050	78,570	0,2236
B4	0,048	78,570	0,2191
AVERAGE	0,0543	78,5600	0,2325

Project nu.	P-20174
Date	03-08-2018
Technicien	M.M

Filter set weight

	System 1 (g) 1st hour				System 1 (g)				System 2 (g)				Ambient blank (g)	Date	Heure
	probe	front	back	gasket	probe	front	back	gasket	probe	front	back	gasket	Filter		
Number	2	806	807	14	21	808	809	27	38	810	811	35	812		
Before (1)															
Before (2)															
Before (3)															
Before (4)															
Before (5)	61,1004	0,1235	0,1242	34,3198	108,7408	0,1261	0,1233	34,1946	110,4341	0,1281	0,1276	34,0323	0,1280	2018-08-02	18:00
Before (6)	61,1005	0,1236	0,1243	34,3197	108,7408	0,1260	0,1234	34,1947	110,4340	0,1280	0,1276	34,0324	0,1279	2018-08-03	09:00
After (1)	61,1011	0,1231	0,1240	34,3260	108,7420	0,1251	0,1228	34,2011	110,4346	0,1278	0,1272	34,0382	0,1283	2018-08-03	18:00
After (2)	61,1009	0,1231	0,1240	34,3217	108,7414	0,1251	0,1227	34,1972	110,4342	0,1277	0,1272	34,0352	0,1281	2018-08-08	08:00
After (3)	61,1005	0,1231	0,1240	34,3217	108,7410	0,1251	0,1227	34,1972	110,4342	0,1277	0,1272	34,0352	0,1281	2018-08-09	08:00
After (4)	61,1005	0,1231	0,1240	34,3217	108,7410	0,1251	0,1227	34,1972	110,4342	0,1277	0,1272	34,0352	0,1281	2018-08-09	17:00
After (5)															
After (6)	61,1005	0,1231	0,1240	34,3217	108,7410	0,1251	0,1227	34,1972	110,4342	0,1277	0,1272	34,0352	0,1281	2018-08-09	17:00
Difference	0,0000	-0,0005	-0,0003	0,0020	0,0002	-0,0009	-0,0007	0,0025	0,0002	-0,0003	-0,0004	0,0028	0,0002		
Total (mg)		1,2				2,3				2,3			0,2		
Total ajusté (mg)		1,00				2,10				2,10					

Project nu.	P-20174
Date	03-08-2018
Technicien	M.M

SFBA EPA EMISSION RESULTS

RESULTS

Average emission rate: 0,7 g/hr
 Burn Rate : 0,994 Dry kg/hr

Test Duration: 376 min

PRESSURE FACTOR: DGM 1 0,97960
 DGM 2 0,98260
 DGM 3 0,99831

BAROMETRIC PRESSURE
 Average: 29,869584 in Hg
 Start: 29,913879 in Hg
 End: 29,825289 in Hg

TEMPERATURE FACTORS DGM 1 0,96521
 DGM 2 0,96521
 DGM 3 0,96790

DGM CONTROLLER VALUES
 DGM 1 Final: 26394,769 Cuft
 Initial: 26328,514 Cuft

VOLUMES SAMPLED DGM 1 61,923 Scft
 DGM 2 61,093 Scft
 DGM 3 133,646 Scft

DGM 2 Final: 24755,847 Cuft
 Initial: 24690,873 Cuft

DGM #3 Final: 610,060 Cuft
 Initial: 471,160 Cuft

TOTAL TUNNEL VOLUME : 116416

TEMPERATURES
 DGM 1 547,031 °R
 DGM 2 547,030 °R

SAMPLE RATIOS
 Sample Train 1: 1880,017
 Sample Train 2: 1905,559

CALIBRATION FACTORS
 DGM 1 0,9885
 DGM 2 0,9914
 DGM #3 0,9958

Paticulate concentration
 Sample Train 1 **0,000037** g/dscf
 Sample Train 2 **0,000038** g/dscf
 Room **0,000001** g/dscf

TUNNEL FLOW RATE: 309,616 Dscfm

TOTAL EMISSIONS
 Sample Train 1 **4,15** g
 Sample Train 2 **4,21** g

PARTICULATE CATCH
 Total Sample Train 1: 2,30 mg
 Total Sample Train 2: 2,30 mg
 Total Sample Train 1 1st hour: 1,20 mg

EMISSION RATES
 Sample Train 1 **0,66** g/hr
 Sample Train 2 **0,67** g/hr

1st hour emission rate **2,26** g/hr

DEVIATION: 0,70%

Cs Train 1 Train 2
 3,714E-05 3,76477E-05

* Elapsed Time	* Raw data row	* Weight		* CO			* O ₂			*1 Flue Gas	*2 Room Temp	*3 Tunnel Dry Bulb	*4 Unit Top	*5 Unit Back	*6 R. Side	*7 L. Side	*8 Unit Bottom	*9 Catalyst	Mass flow 1	DGM 1	DGM 1	Filter 1	Mass flow 2	DGM 2	DGM 2	Filter 2	Tunnel Veloc	
		lbs	%	%	%	%	%	%	%	%	%	%	%	%	%	%	%	%	Down	Reading	Inlet T	Outlet T	Temp	Reading	Inlet T	Outlet T	Temp	in w/c
0.00	215.00	16.4	0.2	2.2	0.0	297.9	83.3	109.6	424.5	389.3	426.6	291.6	255.7	521.9	0.17	85.87	85.75	85.50	0.16	85.50	84.98	85.30	0.06	85.30	84.98	85.30	0.06	85.30
1.0	216.0	16.3	0.5	3.9	0.0	325.7	83.5	102.5	424.7	388.6	424.9	290.6	255.9	587.0	0.17	85.76	85.74	85.55	0.16	85.74	85.55	85.46	0.06	85.74	85.55	85.46	0.06	85.74
2.0	217.0	16.1	0.0	1.1	0.0	351.6	83.3	103.5	427.9	390.0	423.0	289.4	255.6	712.4	0.17	85.71	85.73	85.62	0.16	85.50	85.00	85.36	0.06	85.50	85.00	85.36	0.06	85.50
3.0	218.0	16.0	0.0	1.4	0.0	378.2	83.6	105.3	433.6	393.6	420.8	287.8	255.8	824.5	0.17	85.64	85.74	85.70	0.16	85.50	85.04	85.45	0.06	85.50	85.04	85.45	0.06	85.50
4.0	219.0	15.8	0.0	1.7	0.0	402.2	83.8	107.0	441.9	398.7	418.4	286.3	255.9	906.2	0.17	85.63	85.75	85.78	0.16	85.51	85.05	85.51	0.05	85.51	85.05	85.51	0.05	85.51
5.0	220.0	15.7	0.4	1.9	0.0	362.2	83.9	98.7	445.1	400.4	415.9	285.0	256.1	906.2	0.17	85.68	85.75	85.81	0.16	85.55	85.10	85.48	0.06	85.55	85.10	85.48	0.06	85.55
6.0	221.0	15.7	0.0	4.1	0.0	335.8	83.5	97.8	445.5	400.4	413.3	283.7	255.9	849.0	0.17	85.72	85.75	85.72	0.16	85.58	85.13	85.56	0.06	85.58	85.13	85.56	0.06	85.58
7.0	222.0	15.6	0.0	3.1	0.0	317.8	83.6	96.5	444.2	398.9	410.5	282.0	255.4	782.1	0.17	85.71	85.75	85.90	0.16	85.59	85.15	85.62	0.06	85.59	85.15	85.62	0.06	85.59
8.0	223.0	15.5	0.0	2.8	0.0	306.1	83.6	95.2	442.0	397.1	407.8	279.9	255.2	741.9	0.17	85.69	85.77	85.95	0.16	85.60	85.18	85.70	0.06	85.60	85.18	85.70	0.06	85.60
9.0	224.0	15.5	0.0	2.6	0.0	297.3	83.7	95.3	439.1	394.3	404.7	277.5	254.4	719.2	0.17	85.66	85.77	86.04	0.16	85.56	85.19	85.77	0.06	85.56	85.19	85.77	0.06	85.56
10.0	225.0	15.4	0.0	2.7	0.0	290.4	83.5	94.5	435.3	391.6	401.6	275.1	254.3	708.5	0.17	85.62	85.78	86.07	0.16	85.58	85.23	85.81	0.06	85.58	85.23	85.81	0.06	85.58
11.0	226.0	15.4	0.0	2.8	0.0	286.5	83.4	94.3	431.7	388.8	398.3	272.6	254.3	708.6	0.17	85.61	85.80	86.13	0.16	85.58	85.24	85.86	0.06	85.58	85.24	85.86	0.06	85.58
12.0	227.0	15.3	0.0	3.0	0.0	283.8	83.5	94.0	427.7	386.4	395.5	270.0	254.2	712.8	0.17	85.61	85.78	86.19	0.16	85.60	85.28	85.91	0.06	85.60	85.28	85.91	0.06	85.60
13.0	228.0	15.3	0.0	2.8	0.0	282.2	83.6	94.0	424.3	383.1	391.8	267.0	253.0	714.1	0.17	85.58	85.81	86.25	0.16	85.60	85.30	85.95	0.06	85.60	85.30	85.95	0.06	85.60
14.0	229.0	15.2	0.0	3.5	0.0	282.3	83.6	95.2	421.4	380.6	388.5	264.6	253.3	728.1	0.17	85.60	85.82	86.31	0.16	85.61	85.32	85.98	0.06	85.61	85.32	85.98	0.06	85.61
15.0	230.0	15.2	0.0	4.5	0.0	280.9	83.6	94.9	418.3	378.0	385.4	261.9	253.2	719.7	0.17	85.62	85.82	86.36	0.16	85.63	85.34	86.06	0.06	85.63	85.34	86.06	0.06	85.63
16.0	231.0	15.1	0.0	4.2	0.0	280.0	83.5	94.4	416.1	375.5	359.3	259.3	252.4	722.0	0.17	85.62	85.82	86.40	0.16	85.64	85.37	86.09	0.06	85.64	85.37	86.09	0.06	85.64
17.0	232.0	15.0	0.0	3.6	0.0	280.0	83.5	94.7	413.7	373.2	378.9	256.3	251.4	737.6	0.17	85.58	85.82	86.44	0.16	85.62	85.37	86.08	0.06	85.62	85.37	86.08	0.06	85.62
18.0	233.0	15.0	0.0	3.1	0.0	280.3	83.3	94.6	410.6	371.5	375.8	253.9	252.1	740.4	0.17	85.59	85.82	86.46	0.16	85.63	85.39	86.14	0.06	85.63	85.39	86.14	0.06	85.63
19.0	234.0	14.9	0.0	2.9	0.0	278.9	83.3	94.9	407.9	369.0	372.7	251.4	251.9	732.7	0.17	85.57	85.82	86.49	0.16	85.61	85.40	86.18	0.06	85.61	85.40	86.18	0.06	85.61
20.0	235.0	14.9	0.0	2.9	0.0	276.9	83.2	93.9	404.0	369.0	369.0	249.0	250.4	722.0	0.17	85.56	85.85	86.50	0.16	85.61	85.42	86.21	0.06	85.61	85.42	86.21	0.06	85.61
21.0	236.0	14.8	0.0	3.0	0.0	275.4	83.0	94.5	400.6	364.4	366.9	246.1	249.7	712.4	0.17	85.53	85.84	86.53	0.16	85.60	85.44	86.24	0.06	85.60	85.44	86.24	0.06	85.60
22.0	237.0	14.8	0.0	3.3	0.0	274.4	83.2	93.8	397.4	362.1	363.8	243.5	250.0	708.5	0.17	85.52	85.85	86.55	0.16	85.60	85.44	86.24	0.06	85.60	85.44	86.24	0.06	85.60
23.0	238.0	14.7	0.0	3.9	0.0	273.3	83.2	94.4	394.8	359.6	360.9	241.3	250.1	702.8	0.17	85.52	85.84	86.55	0.16	85.62	85.45	86.27	0.06	85.62	85.45	86.27	0.06	85.62
24.0	239.0	14.6	0.0	4.4	0.0	271.4	83.3	93.8	392.7	356.8	358.1	238.8	249.0	695.4	0.17	85.53	85.84	86.55	0.16	85.58	85.45	86.27	0.06	85.58	85.45	86.27	0.06	85.58
25.0	240.0	14.6	0.0	4.9	0.0	270.5	83.2	94.9	391.1	354.1	354.1	236.8	248.6	701.8	0.17	85.48	85.84	86.57	0.16	85.58	85.46	86.31	0.06	85.58	85.46	86.31	0.06	85.58
26.0	241.0	14.5	0.0	5.1	0.0	271.6	83.3	94.1	389.9	352.1	352.7	234.6	247.8	710.6	0.17	85.49	85.85	86.56	0.16	85.59	85.49	86.33	0.06	85.59	85.49	86.33	0.06	85.59
27.0	242.0	14.4	0.0	6.4	0.0	274.0	82.9	93.7	389.8	350.4	350.1	232.5	247.2	724.7	0.17	85.47	85.83	86.59	0.16	85.58	85.48	86.35	0.06	85.58	85.48	86.35	0.06	85.58
28.0	243.0	14.3	0.0	6.5	0.0	276.8	83.5	94.7	390.6	349.3	347.8	230.9	246.3	739.6	0.17	85.46	85.83	86.60	0.16	85.58	85.50	86.36	0.06	85.58	85.50	86.36	0.06	85.58
29.0	244.0	14.2	0.0	6.6	0.0	279.0	83.4	94.8	391.9	348.6	345.2	228.9	246.3	739.7	0.17	85.47	85.83	86.61	0.16	85.59	85.50	86.33	0.06	85.59	85.50	86.33	0.06	85.59
30.0	245.0	14.2	0.0	7.0	0.0	280.3	83.3	94.4	394.4	348.1	343.1	227.4	245.7	740.3	0.17	85.47	85.84	86.60	0.16	85.56	85.49	86.33	0.06	85.56	85.49	86.33	0.06	85.56
31.0	246.0	14.1	0.0	7.0	0.0	282.5	83.3	94.6	394.4	347.4	344.1	225.9	244.5	752.9	0.17	85.45	85.82	86.63	0.16	85.54	85.49	86.35	0.06	85.54	85.49	86.35	0.06	85.54
32.0	247.0	14.0	0.0	7.0	0.0	284.3	83.4	94.9	399.4	347.5	339.3	224.6	244.2	767.7	0.17	85.46	85.83	86.65	0.16	85.53	85.51	86.34	0.06	85.53	85.51	86.34	0.06	85.53
33.0	248.0	13.9	0.0	7.2	0.0	286.3	83.3	94.5	402.7	347.9	337.9	223.6	244.0	776.4	0.17	85.43	85.81	86.66	0.16	85.54	85.48	86.35	0.06	85.54	85.48	86.35	0.06	85.54
34.0	249.0	13.8	0.0	7.4	0.0	290.2	83.4	94.9	406.6	348.1	336.6	222.4	242.6	796.0	0.17	85.44	85.81	86.65	0.16	85.55	85.54	86.37	0.06	85.55	85.54	86.37	0.06	85.55
35.0	250.0	13.7	0.1	8.8	0.0	297.4	83.6	95.6	410.3	349.2	335.3	221.3	241.8	854.7	0.17	85.42	85.81	86.66	0.16	85.53	85.55	86.38	0.06	85.53	85.55	86.38	0.06	85.53
36.0	251.0	13.6	0.1	9.0	0.0	305.9	83.6	96.1	414.8	351.8	334.2	220.6	242.0	894.2	0.17	85.45	85.78	86.67	0.16	85.51	85.52	86.37	0.06	85.51	85.52	86.37	0.06	85.51
37.0	252.0	13.5	0.1	9.1	0.0	310.0	83.7	96.4	418.7	353.7	333.3	220.0	241.2	902.3	0.17	85.47	85.77	86.68	0.16	85.52	85.50	86.39	0.06	85.52	85.50	86.39	0.06	85.52
38.0	253.0	13.4	0.0	8.6	0.0	313.9	83.6	96.8	422.8	355.9	332.6	219.3	240.5	908.1	0.17	85.49	85.77	86.68	0.16	85.54	85.52	86.38	0.06	85.54	85.52	86.38	0.06	85.54
39.0	254.0	13.3	0.1	8.1	0.0	317.6	83.5	96.3	426.1	358.7	331.8	219.0	240.3	921.9	0.17	85.55	85.77	86.68	0.16	85.58	85.53	86.39	0.06	85.58	85.53	86.39	0.06	85.58
40.0	255.0	13.2	0.1	9.0	0.0	321.0	83.6	96.3	430.0	361.5	331.4	218.8	239.3	932.1	0.17	85.56	85.78	86.72	0.16	85.61	85.53	86.40	0.06	85.61	85.53	86.40	0.06	85.61
41.0	256.0	13.1	0.3	9.5	0.0	324.1	83.8	97.2	435.7	364.6	331.2	218.4	239.2	929.6	0.17	85.54	85.77	86.73	0.16	85.62	85.54	86.43	0.06	85.62	85.54	86.43	0.06	85.62
42.0	257.0	12.9	0.2	9.7	0.0																							

95.0	310.0	7.3	0.5	9.8	0.0	331.5	85.4	96.5	574.6	425.7	396.0	286.5	199.0	856.5	0.17	86.74	85.97	87.37	0.16	86.59	85.99	86.94	0.06
96.0	311.0	7.2	0.5	9.7	0.0	331.4	85.1	97.1	575.7	426.4	397.1	287.3	199.3	854.2	0.17	86.78	85.99	87.40	0.16	86.63	86.00	86.99	0.06
97.0	312.0	7.1	0.4	9.7	0.0	330.9	85.2	97.6	576.2	426.5	398.1	286.0	198.8	851.3	0.17	86.80	86.02	87.41	0.16	86.67	86.04	87.04	0.06
98.0	313.0	7.0	0.4	9.6	0.0	330.2	85.6	98.0	577.1	427.4	399.2	285.6	197.9	847.8	0.17	86.83	86.05	87.42	0.16	86.71	86.06	87.09	0.06
99.0	314.0	6.9	0.3	9.6	0.0	329.4	85.1	97.2	578.3	428.2	400.3	285.3	198.2	845.9	0.17	86.82	86.06	87.45	0.16	86.73	86.08	87.13	0.06
100.0	315.0	6.8	0.2	9.6	0.0	328.2	85.0	96.7	577.6	428.3	401.4	284.9	197.4	842.6	0.17	86.84	86.08	87.47	0.16	86.74	86.09	87.18	0.06
101.0	316.0	6.8	0.1	9.6	0.0	327.4	85.2	97.3	579.0	428.8	402.4	284.6	197.2	833.8	0.17	86.90	86.10	87.49	0.16	86.79	86.14	87.24	0.06
102.0	317.0	6.7	0.0	9.4	0.0	326.4	84.9	96.4	579.9	429.2	403.3	291.5	196.9	829.8	0.17	86.91	86.13	87.50	0.16	86.83	86.15	87.28	0.06
103.0	318.0	6.6	0.0	9.4	0.0	325.2	84.7	96.5	581.2	429.2	404.5	292.0	196.4	827.0	0.17	86.96	86.17	87.52	0.16	86.88	86.18	87.32	0.06
104.0	319.0	6.5	0.0	9.4	0.0	323.9	85.4	96.8	582.3	429.3	405.9	292.9	195.9	818.6	0.17	86.94	86.17	87.53	0.16	86.87	86.19	87.37	0.06
105.0	320.0	6.5	0.0	9.1	0.0	322.5	85.5	97.1	579.5	429.6	406.5	293.7	195.4	804.2	0.17	86.99	86.20	87.55	0.16	86.90	86.22	87.41	0.06
106.0	321.0	6.4	0.0	9.0	0.0	321.5	85.2	96.7	579.5	429.7	407.3	294.7	195.0	797.0	0.17	87.03	86.22	87.58	0.16	86.93	86.24	87.46	0.06
107.0	322.0	6.3	0.0	9.0	0.0	319.9	84.4	96.9	578.8	429.1	408.2	296.1	194.8	796.6	0.17	87.08	86.26	87.60	0.16	86.99	86.27	87.51	0.06
108.0	323.0	6.3	0.0	9.0	0.0	318.3	85.1	96.7	578.9	428.5	409.1	297.3	194.1	797.8	0.17	87.11	86.29	87.61	0.16	87.02	86.30	87.55	0.06
109.0	324.0	6.2	0.0	9.0	0.0	317.6	85.4	96.9	578.9	428.3	410.0	298.4	194.1	797.2	0.17	87.19	86.31	87.63	0.16	87.08	86.33	87.58	0.06
110.0	325.0	6.1	0.0	9.0	0.0	316.9	85.4	97.0	578.9	427.7	410.7	299.2	193.7	799.0	0.17	87.19	86.32	87.67	0.16	87.09	86.33	87.62	0.06
111.0	326.0	6.1	0.0	9.0	0.0	316.1	85.6	96.3	577.7	427.2	411.8	300.2	193.4	799.7	0.17	87.24	86.37	87.67	0.16	87.14	86.37	87.66	0.06
112.0	327.0	6.0	0.0	9.2	0.0	316.0	85.8	96.7	578.4	426.8	412.6	300.8	192.9	802.9	0.17	87.31	86.39	87.69	0.16	87.19	86.39	87.69	0.06
113.0	328.0	5.9	0.0	9.2	0.0	315.5	85.0	96.2	578.8	426.6	413.2	301.4	192.4	809.8	0.17	87.35	86.43	87.72	0.16	87.24	86.40	87.75	0.06
114.0	329.0	5.9	0.0	9.4	0.0	316.1	85.3	96.3	578.7	426.7	413.9	301.6	192.3	818.8	0.17	87.40	86.45	87.75	0.16	87.28	86.42	87.77	0.06
115.0	330.0	5.8	0.0	9.6	0.0	317.2	85.6	96.3	579.0	426.8	414.6	302.0	192.0	830.1	0.17	87.43	86.49	87.75	0.16	87.29	86.45	87.80	0.06
116.0	331.0	5.7	0.1	9.7	0.0	317.5	85.4	97.3	580.5	426.4	415.1	302.4	192.5	840.1	0.17	87.40	86.51	87.82	0.16	87.30	86.48	87.87	0.06
117.0	332.0	5.6	0.1	9.8	0.0	317.3	85.7	98.0	580.1	426.4	416.2	302.5	191.3	844.7	0.17	87.41	86.53	87.83	0.16	87.32	86.51	87.89	0.06
118.0	333.0	5.6	0.1	9.7	0.0	317.4	85.6	96.0	579.8	427.3	416.9	303.2	191.3	846.5	0.17	87.46	86.56	87.86	0.16	87.36	86.55	87.92	0.06
119.0	334.0	5.5	0.1	9.7	0.0	316.9	85.2	97.1	580.6	428.0	417.5	303.7	190.4	846.8	0.17	87.45	86.57	87.86	0.16	87.36	86.56	87.94	0.06
120.0	335.0	5.4	0.2	9.8	0.0	317.4	85.3	97.6	581.2	428.6	418.4	304.3	190.5	847.8	0.17	87.46	86.59	87.88	0.16	87.37	86.55	87.96	0.06
121.0	336.0	5.3	0.4	9.8	0.0	317.5	85.2	97.1	581.9	429.3	419.1	305.0	189.4	847.3	0.17	87.52	86.62	87.93	0.16	87.42	86.59	87.99	0.06
122.0	337.0	5.3	0.3	9.7	0.0	317.0	85.7	97.1	582.1	429.9	420.0	305.7	188.8	848.3	0.17	87.55	86.65	87.93	0.16	87.46	86.60	88.02	0.06
123.0	338.0	5.2	0.2	9.6	0.0	316.6	85.2	96.8	582.2	431.0	420.8	306.5	189.1	850.4	0.17	87.56	86.66	87.93	0.16	87.46	86.62	88.01	0.06
124.0	339.0	5.1	0.1	9.6	0.0	316.0	85.6	97.1	582.9	431.8	421.8	306.9	188.8	851.0	0.17	87.61	86.67	87.97	0.16	87.49	86.62	88.05	0.06
125.0	340.0	5.1	0.0	9.3	0.0	314.3	85.3	97.1	582.7	432.5	422.7	307.5	188.8	841.3	0.17	87.62	86.70	87.99	0.16	87.49	86.64	88.08	0.06
126.0	341.0	5.0	0.0	9.7	0.0	312.1	85.5	96.7	582.8	433.1	423.7	308.0	188.2	823.5	0.17	87.64	86.71	87.98	0.16	87.52	86.67	88.09	0.06
127.0	342.0	5.0	0.0	9.2	0.0	310.0	85.2	96.5	582.3	432.7	424.4	308.4	187.5	808.2	0.17	87.70	86.76	88.04	0.16	87.58	86.68	88.15	0.06
128.0	343.0	4.9	0.0	8.3	0.0	308.0	85.7	96.2	581.4	432.5	425.6	308.5	187.1	798.6	0.17	87.71	86.77	88.02	0.16	87.59	86.70	88.16	0.06
129.0	344.0	4.9	0.0	8.2	0.0	306.5	85.3	96.5	580.4	432.4	426.4	308.7	186.8	792.2	0.17	87.72	86.82	88.04	0.16	87.62	86.75	88.19	0.06
130.0	345.0	4.8	0.0	8.1	0.0	304.6	85.5	95.7	578.7	431.8	427.2	308.8	186.8	788.3	0.17	87.76	86.84	88.04	0.16	87.65	86.77	88.20	0.06
131.0	346.0	4.8	0.0	8.2	0.0	303.0	85.7	97.0	577.1	430.5	428.1	309.0	186.8	788.7	0.17	87.76	86.85	88.07	0.16	87.65	86.78	88.21	0.06
132.0	347.0	4.7	0.0	8.2	0.0	301.9	85.3	96.2	575.9	429.8	428.8	308.7	186.4	789.2	0.17	87.75	86.87	88.10	0.16	87.65	86.78	88.24	0.06
133.0	348.0	4.7	0.0	8.3	0.0	300.9	85.7	96.5	574.9	429.0	429.1	308.6	186.6	788.7	0.17	87.76	86.91	88.10	0.16	87.70	86.82	88.27	0.06
134.0	349.0	4.6	0.0	8.4	0.0	300.0	85.5	96.6	574.1	428.0	429.7	308.6	186.3	783.3	0.17	87.74	86.93	88.12	0.16	87.68	86.84	88.28	0.06
135.0	350.0	4.6	0.0	8.5	0.0	299.0	85.5	95.8	573.2	427.0	430.0	308.7	185.7	770.5	0.17	87.74	86.95	88.14	0.16	87.69	86.88	88.31	0.06
136.0	351.0	4.5	0.0	8.5	0.0	297.7	85.6	96.3	571.8	426.1	430.3	309.1	185.7	761.5	0.17	87.74	86.96	88.16	0.16	87.69	86.89	88.33	0.06
137.0	352.0	4.5	0.0	8.4	0.0	296.3	86.1	95.8	571.1	425.1	430.6	309.7	185.2	755.4	0.17	87.73	86.99	88.18	0.16	87.72	86.92	88.35	0.06
138.0	353.0	4.5	0.0	8.2	0.0	294.8	86.1	95.3	570.4	424.2	430.6	310.6	184.8	749.2	0.17	87.69	87.01	88.16	0.16	87.71	86.93	88.34	0.06
139.0	354.0	4.4	0.0	8.0	0.0	293.5	85.1	94.8	569.3	423.5	430.6	311.7	184.9	743.3	0.17	87.67	87.04	88.16	0.16	87.71	86.93	88.31	0.06
140.0	355.0	4.4	0.0	7.8	0.0	292.2	85.4	96.2	567.7	422.6	430.6	312.4	184.6	738.3	0.17	87.70	87.04	88.18	0.16	87.70	86.95	88.33	0.06
141.0	356.0	4.3	0.0	7.8	0.0	290.5	85.0	95.6	566.2	421.3	430.6	313.3	184.1	734.3	0.17	87.73	87.05	88.18	0.16	87.73	86.96	88.35	0.06
142.0	357.0	4.3	0.0	7.8	0.0	289.4	85.3	96.1	565.5	420.5	430.7	313.7	184.0	730.8	0.17	87.73	87.06	88.18	0.16	87.72	86.95	88.37	0.06
143.0	358.0	4.2	0.0	7.9	0.0	288.0	85.5	94.6	561.7	419.7	429.7	314.2	184.1	726.7	0.17	87.69	87.09	88.18	0.16	87.70	86.97	88.37	0.06
144.0	359.0	4.2	0.0	7.8	0.0	286.8	85.5	95.8	560.6	418.9	429.3	314.3	183.9	722.7	0.17	87.67	87.07	88.17	0.16	87.68	86.98	88.37	0.06
145.0	360.0	4.2	0.0	7.8	0.0	286.1	85.7	94.8	559.2	417.8	428.9	314.6	183.5	718.7	0.17	87.67	87.09	88.19	0.16	87.69	86.98	88.38	0.06
146.0	361.0	4.1	0.0	7.7	0.0	284.8	84.9	95.2	557.5	417.2	428.4	314.9	183.6	714.8	0.17	87.76	87.11	88.20	0.16	87.73	87.00	88.41	0.06
147.0	362.0	4.1	0.0	7.5	0.0	282.8	85.6	94.6	555.0	415.9	428.0	315.1	183.1	711.8	0.17	87.76	87.12	88.20	0.16	87.74	87.03	88.41	0

194.0	409.0	3.0	0.0	257.6	85.1	92.8	449.5	388.2	413.7	287.0	181.5	712.8	0.17	87.28	87.44	87.76	0.16	87.53	87.42	87.95	0.06
195.0	410.0	2.9	0.0	257.0	85.2	92.8	448.5	387.6	413.6	286.8	181.7	712.1	0.17	87.27	87.42	87.73	0.16	87.50	87.39	87.93	0.06
196.0	411.0	2.9	0.0	256.6	85.6	92.7	447.3	387.2	413.0	286.5	182.3	711.9	0.17	87.30	87.44	87.75	0.16	87.50	87.38	87.94	0.06
197.0	412.0	2.9	0.0	256.2	85.5	92.7	446.4	386.5	412.4	286.4	182.0	712.3	0.17	87.45	87.42	87.70	0.16	87.45	87.39	87.92	0.06
198.0	413.0	2.9	0.0	255.9	85.3	92.9	445.0	386.3	412.7	285.4	182.6	712.1	0.17	87.11	87.40	87.68	0.16	87.37	87.39	87.90	0.06
199.0	414.0	2.9	0.0	255.7	85.3	92.2	443.8	386.1	412.5	285.0	183.4	711.7	0.17	87.09	87.39	87.68	0.16	87.34	87.34	87.89	0.06
200.0	415.0	2.8	0.0	254.8	85.8	94.2	443.4	385.6	412.3	284.8	183.8	710.7	0.17	87.13	87.36	87.66	0.16	87.33	87.34	87.88	0.06
201.0	416.0	2.8	0.0	254.4	85.5	93.2	441.9	385.3	411.9	284.2	183.9	709.0	0.17	87.13	87.37	87.68	0.16	87.33	87.33	87.90	0.06
202.0	417.0	2.8	0.0	253.7	85.7	93.9	441.6	384.6	411.6	284.0	184.8	708.0	0.17	87.15	87.39	87.68	0.16	87.36	87.35	87.88	0.06
203.0	418.0	2.8	0.0	253.0	85.8	93.7	440.6	384.4	411.4	283.4	184.4	707.4	0.17	87.21	87.38	87.71	0.16	87.38	87.31	87.68	0.06
204.0	419.0	2.8	0.0	252.2	85.7	93.6	438.5	384.1	411.2	282.7	184.1	707.7	0.17	87.25	87.38	87.70	0.16	87.41	87.36	87.88	0.06
205.0	420.0	2.7	0.0	252.3	85.7	92.9	437.5	383.3	410.9	282.3	184.5	704.5	0.17	87.30	87.39	87.70	0.16	87.44	87.36	87.90	0.06
206.0	421.0	2.7	0.0	252.7	86.0	93.9	436.5	383.3	410.7	281.8	185.2	695.9	0.17	87.31	87.39	87.71	0.16	87.44	87.36	87.89	0.06
207.0	422.0	2.7	0.0	252.2	85.9	93.4	435.3	382.9	410.4	281.3	185.2	690.1	0.17	87.34	87.42	87.72	0.16	87.45	87.38	87.93	0.06
208.0	423.0	2.7	0.0	251.9	85.9	93.9	434.2	382.3	409.6	281.0	186.0	685.7	0.17	87.38	87.42	87.69	0.16	87.48	87.37	87.91	0.06
209.0	424.0	2.7	0.0	251.4	86.1	93.4	433.0	381.6	408.2	280.4	185.8	682.1	0.17	87.38	87.41	87.71	0.16	87.50	87.36	87.92	0.06
210.0	425.0	2.6	0.0	250.1	85.6	92.9	432.6	381.0	408.8	280.1	186.2	680.0	0.17	87.39	87.42	87.71	0.16	87.51	87.38	87.93	0.06
211.0	426.0	2.6	0.0	249.6	86.0	93.1	430.9	380.7	408.3	279.7	186.5	678.8	0.17	87.40	87.44	87.71	0.16	87.53	87.39	87.95	0.06
212.0	427.0	2.6	0.0	249.1	86.0	93.1	429.8	380.1	407.7	279.3	186.5	676.0	0.17	87.42	87.46	87.73	0.16	87.54	87.38	87.97	0.06
213.0	428.0	2.6	0.0	248.0	86.1	92.8	429.4	379.8	407.1	278.8	187.1	674.0	0.17	87.44	87.47	87.73	0.16	87.55	87.39	87.96	0.06
214.0	429.0	2.6	0.0	247.6	86.3	92.6	428.2	379.2	406.7	278.4	187.3	672.6	0.17	87.45	87.50	87.74	0.16	87.56	87.40	87.98	0.06
215.0	430.0	2.5	0.0	247.1	86.1	92.1	427.2	378.5	406.3	278.2	187.4	671.6	0.17	87.42	87.48	87.77	0.16	87.55	87.39	87.98	0.06
216.0	431.0	2.5	0.0	246.3	86.3	92.1	427.2	378.8	405.9	278.2	187.8	670.5	0.17	87.39	87.49	87.78	0.16	87.52	87.40	87.99	0.06
217.0	432.0	2.5	0.0	245.9	86.1	92.6	426.3	377.1	405.8	277.7	188.0	669.8	0.17	87.37	87.49	87.79	0.16	87.51	87.41	87.99	0.06
218.0	433.0	2.5	0.0	245.5	86.2	92.9	425.5	376.7	405.6	277.5	188.3	669.9	0.17	87.35	87.49	87.78	0.16	87.49	87.40	87.97	0.06
219.0	434.0	2.5	0.0	245.3	86.3	92.9	424.7	376.3	405.2	277.4	188.6	670.4	0.17	87.40	87.49	87.78	0.16	87.52	87.43	88.00	0.06
220.0	435.0	2.5	0.0	245.0	86.3	92.4	423.9	375.9	404.6	277.1	189.1	670.9	0.17	87.41	87.50	87.82	0.16	87.54	87.43	88.01	0.06
221.0	436.0	2.4	0.0	244.5	85.9	92.4	423.5	375.8	404.5	277.0	189.3	670.6	0.17	87.37	87.49	87.82	0.16	87.53	87.44	88.01	0.06
222.0	437.0	2.4	0.0	243.9	86.0	92.3	422.7	374.8	403.8	276.8	189.8	670.8	0.17	87.35	87.51	87.81	0.16	87.52	87.45	88.01	0.06
223.0	438.0	2.4	0.0	243.6	85.6	92.1	422.3	374.3	403.3	276.7	190.1	669.8	0.17	87.35	87.52	87.83	0.16	87.51	87.47	88.03	0.06
224.0	439.0	2.4	0.0	243.3	86.2	93.7	422.3	373.4	403.1	276.8	190.0	669.4	0.17	87.38	87.52	87.83	0.16	87.52	87.45	88.00	0.06
225.0	440.0	2.4	0.0	243.2	85.6	92.7	421.3	373.2	402.8	276.5	189.8	669.3	0.17	87.38	87.52	87.82	0.16	87.53	87.45	88.00	0.06
226.0	441.0	2.4	0.0	243.1	85.6	92.1	420.6	373.0	402.8	276.2	189.9	669.6	0.17	87.40	87.52	87.83	0.16	87.54	87.47	88.01	0.06
227.0	442.0	2.3	0.0	242.7	85.7	92.5	420.2	372.5	402.4	276.0	190.2	669.9	0.17	87.38	87.51	87.82	0.16	87.52	87.46	88.00	0.06
228.0	443.0	2.3	0.0	242.1	86.0	92.3	419.8	372.1	401.8	275.8	190.5	671.0	0.17	87.37	87.52	87.83	0.16	87.52	87.46	88.02	0.06
229.0	444.0	2.3	0.0	242.3	86.3	92.6	419.1	371.7	401.8	275.7	190.7	672.3	0.17	87.37	87.52	87.83	0.16	87.52	87.47	88.01	0.06
230.0	445.0	2.3	0.0	242.2	85.9	92.6	418.7	371.1	401.4	275.3	190.9	673.1	0.17	87.40	87.53	87.83	0.16	87.54	87.47	88.01	0.06
231.0	446.0	2.3	0.0	242.2	86.1	92.6	418.1	371.0	401.2	275.2	190.6	673.9	0.17	87.42	87.53	87.87	0.16	87.57	87.49	88.03	0.06
232.0	447.0	2.3	0.0	242.2	86.3	92.9	417.7	370.6	400.9	275.1	190.9	674.5	0.17	87.44	87.54	87.86	0.16	87.58	87.49	88.01	0.06
233.0	448.0	2.2	0.0	242.0	85.7	92.7	417.3	370.3	400.6	274.8	191.0	675.4	0.17	87.47	87.56	87.87	0.16	87.58	87.50	88.01	0.06
234.0	449.0	2.2	0.0	242.5	85.9	92.8	416.8	369.7	400.5	274.6	190.9	677.6	0.17	87.49	87.57	87.88	0.16	87.61	87.52	88.01	0.06
235.0	450.0	2.2	0.0	242.0	86.2	92.2	416.0	369.5	400.4	274.6	191.5	680.7	0.17	87.49	87.56	87.88	0.16	87.61	87.51	88.02	0.06
236.0	451.0	2.2	0.0	242.4	85.5	92.7	415.8	369.2	400.2	274.3	191.5	682.8	0.17	87.43	87.55	87.89	0.16	87.57	87.50	88.00	0.06
237.0	452.0	2.2	0.0	242.8	85.6	92.4	415.2	368.9	400.0	274.2	191.6	683.7	0.17	87.42	87.54	87.92	0.16	87.56	87.50	88.03	0.06
238.0	453.0	2.2	0.0	242.9	86.0	92.9	414.9	368.4	399.6	274.2	191.7	684.1	0.17	87.47	87.57	87.91	0.16	87.59	87.51	88.01	0.06
239.0	454.0	2.1	0.0	242.9	85.9	92.2	414.6	367.9	399.1	274.1	191.8	685.1	0.17	87.42	87.57	87.90	0.16	87.58	87.53	88.01	0.06
240.0	455.0	2.1	0.0	243.5	85.9	92.5	414.1	368.0	399.0	274.0	192.3	686.5	0.17	87.38	87.57	87.94	0.16	87.56	87.54	88.00	0.06
241.0	456.0	2.1	0.0	243.3	85.8	92.7	413.7	367.8	398.7	273.8	192.1	687.5	0.17	87.33	87.57	87.88	0.16	87.53	87.55	88.00	0.06
242.0	457.0	2.1	0.0	243.4	85.9	92.1	413.3	367.3	398.1	273.7	192.4	687.9	0.17	87.33	87.57	87.86	0.16	87.55	87.51	88.01	0.06
243.0	458.0	2.1	0.0	243.1	85.8	91.9	412.7	366.6	397.7	273.4	192.1	686.3	0.17	87.26	87.57	87.89	0.16	87.51	87.54	87.98	0.06
244.0	459.0	2.1	0.0	243.2	85.7	91.4	412.8	366.5	397.6	273.4	192.2	685.8	0.17	87.21	87.55	87.84	0.16	87.47	87.53	87.97	0.06
245.0	460.0	2.0	0.0	243.1	85.2	91.4	411.9	365.9	397.5	273.2	192.2	686.2	0.17	87.18	87.53	87.81	0.16	87.45	87.51	87.95	0.06
246.0	461.0	2.0	0.0	243.0	85.4	91.6	411.3	365.7	397.3	273.2	192.3	686.8	0.17	87.15	87.52	87.78	0.16	87.48	87.48	87.94	0.06
247.0	462.0	2.0	0.0	243.3	86.7	92.3	411.1	365.5	397.0	272.9	192.8	687.0	0.17	87.06	87.49	87.74	0.16	87.47	87.44	87.94	0.06
248.0	463.0	2.0	0.0	242.8	85.7	91.1	410.6	365.0	397.1	272.7	192.6	687.1	0.17	87.03	87.47	87.70	0.16	87.26	87.40	87.89	0.06
249.0	464.0	2.0	0.0	242.6	85.8	91.9	410.6	364.6	396.7	272.9	193.6	687.9	0.17	87.00	87.45	87.70	0.16	87.21	87.39	87.86	0.06
250.0	465.0	2.0	0.0	243.2	85.3	91.2	410.2	364.5	396.7	272.8	193.2	689.5	0.17	87.02	87.42	87.68	0.16	87.20			

293.0	508.0	1.2	0.0	6.4	0.0	234.9	86.7	93.0	389.9	346.6	380.9	262.4	197.4	649.6	0.17	87.66	87.58	87.88	0.16	87.71	87.60	87.87	0.06
294.0	509.0	1.2	0.0	6.5	0.0	234.7	86.3	92.7	389.8	346.2	380.5	262.2	197.5	648.9	0.17	87.71	87.58	87.89	0.16	87.75	87.62	87.89	0.06
295.0	510.0	1.2	0.0	6.4	0.0	234.3	86.9	92.8	389.3	345.7	380.2	261.9	197.5	648.0	0.17	87.76	87.60	87.92	0.16	87.80	87.61	87.89	0.06
296.0	511.0	1.2	0.0	6.4	0.0	234.0	86.9	92.7	389.5	345.1	379.7	261.6	197.5	647.5	0.17	87.77	87.61	87.93	0.16	87.81	87.62	87.94	0.06
297.0	512.0	1.2	0.0	6.4	0.0	233.8	87.0	93.5	388.8	344.7	379.6	261.4	197.7	648.0	0.17	87.80	87.61	87.94	0.16	87.85	87.64	87.93	0.06
298.0	513.0	1.2	0.0	6.4	0.0	233.7	86.9	92.8	388.8	344.2	379.4	261.5	197.8	648.4	0.17	87.85	87.62	87.97	0.16	87.89	87.65	87.96	0.06
299.0	514.0	1.1	0.0	6.4	0.0	233.8	86.8	92.9	388.6	344.0	378.9	261.3	198.2	648.5	0.17	87.89	87.65	87.99	0.16	87.92	87.65	87.96	0.06
300.0	515.0	1.1	0.0	6.3	0.0	233.4	86.9	93.9	388.3	343.6	378.9	261.1	198.1	648.9	0.17	87.90	87.64	88.00	0.16	87.92	87.66	88.01	0.06
301.0	516.0	1.1	0.0	6.4	0.0	233.4	87.1	93.3	387.9	343.5	378.7	261.0	198.3	649.7	0.17	87.93	87.66	88.01	0.16	87.97	87.67	88.01	0.06
302.0	517.0	1.1	0.0	6.4	0.0	233.6	86.8	93.1	387.4	343.4	378.3	261.0	198.2	649.9	0.17	87.95	87.67	88.04	0.16	87.98	87.69	88.04	0.06
303.0	518.0	1.1	0.0	6.4	0.0	233.6	87.0	93.3	387.3	343.0	378.2	260.6	198.2	652.3	0.17	87.97	87.67	88.04	0.16	87.98	87.70	88.02	0.06
304.0	519.0	1.1	0.0	6.4	0.0	233.7	87.1	93.1	386.9	342.6	377.9	260.2	198.5	653.2	0.17	87.95	87.67	88.06	0.16	87.97	87.72	88.06	0.06
305.0	520.0	1.0	0.0	6.3	0.0	233.8	87.0	94.0	387.0	342.3	377.9	259.8	198.5	654.2	0.17	87.96	87.66	88.09	0.16	87.99	87.70	88.07	0.06
306.0	521.0	1.0	0.0	6.3	0.0	233.7	87.0	92.6	386.7	342.4	377.5	259.7	198.8	655.3	0.17	88.00	87.70	88.10	0.16	88.03	87.71	88.11	0.06
307.0	522.0	1.0	0.0	6.3	0.0	233.8	87.3	93.6	386.5	342.3	377.4	259.6	198.9	656.4	0.17	88.02	87.71	88.12	0.16	88.05	87.72	88.11	0.06
308.0	523.0	1.0	0.0	6.4	0.0	233.9	87.1	92.6	386.4	342.1	377.3	259.4	198.8	657.7	0.17	88.02	87.70	88.11	0.16	88.05	87.72	88.11	0.06
309.0	524.0	1.0	0.0	6.3	0.0	234.3	87.0	92.8	386.4	341.7	377.1	259.1	198.8	659.1	0.17	88.04	87.72	88.13	0.16	88.08	87.74	88.13	0.06
310.0	525.0	1.0	0.0	6.3	0.0	234.5	87.2	92.8	386.2	341.7	377.0	258.9	198.9	659.7	0.17	88.04	87.73	88.17	0.16	88.09	87.77	88.14	0.06
311.0	526.0	0.9	0.0	6.3	0.0	234.4	87.2	92.8	386.0	341.7	376.7	258.8	199.2	660.4	0.17	88.06	87.74	88.15	0.16	88.12	87.77	88.18	0.06
312.0	527.0	0.9	0.0	6.3	0.0	234.6	87.3	93.0	385.6	341.7	376.7	258.6	199.1	661.5	0.17	88.08	87.75	88.19	0.16	88.15	87.78	88.19	0.06
313.0	528.0	0.9	0.0	6.3	0.0	235.1	87.0	92.7	385.3	341.4	376.7	258.4	199.2	662.9	0.17	88.10	87.75	88.20	0.16	88.15	87.79	88.23	0.06
314.0	529.0	0.9	0.0	6.3	0.0	235.2	87.0	93.2	385.1	341.3	376.4	258.3	199.1	663.9	0.17	88.07	87.76	88.21	0.16	88.13	87.81	88.21	0.06
315.0	530.0	0.9	0.0	6.3	0.0	235.2	87.2	93.2	384.6	341.0	376.0	258.0	199.2	667.6	0.17	88.06	87.76	88.22	0.16	88.16	87.81	88.23	0.06
316.0	531.0	0.9	0.0	6.3	0.0	235.1	87.1	93.4	384.9	340.9	375.8	257.9	199.2	664.5	0.17	88.05	87.76	88.23	0.16	88.12	87.81	88.24	0.06
317.0	532.0	0.9	0.0	6.2	0.0	235.0	87.3	93.0	384.4	340.9	375.8	257.7	199.4	665.1	0.17	88.09	87.78	88.24	0.16	88.16	87.83	88.26	0.06
318.0	533.0	0.8	0.0	6.2	0.0	235.2	87.0	93.0	384.3	340.7	375.7	257.5	199.2	666.1	0.17	88.04	87.75	88.25	0.16	88.13	87.82	88.27	0.06
319.0	534.0	0.8	0.0	6.2	0.0	235.1	87.3	94.3	384.3	340.7	375.4	257.4	199.7	666.4	0.17	88.05	87.78	88.28	0.16	88.14	87.85	88.29	0.06
320.0	535.0	0.8	0.0	6.2	0.0	235.3	87.4	93.3	383.9	340.7	375.3	257.6	199.8	666.7	0.17	88.04	87.77	88.27	0.16	88.15	87.84	88.26	0.06
321.0	536.0	0.8	0.0	6.2	0.0	235.5	87.0	92.6	383.7	340.6	374.9	257.5	199.9	667.1	0.17	88.08	87.80	88.28	0.16	88.16	87.84	88.30	0.06
322.0	537.0	0.8	0.0	6.2	0.0	235.5	87.4	93.1	383.2	340.4	374.5	257.3	200.0	666.4	0.17	88.09	87.81	88.29	0.16	88.18	87.86	88.34	0.06
323.0	538.0	0.8	0.0	6.2	0.0	235.5	86.8	92.6	383.0	340.2	374.5	257.1	199.9	665.8	0.17	88.06	87.81	88.29	0.16	88.18	87.85	88.32	0.06
324.0	539.0	0.7	0.0	6.1	0.0	235.6	86.7	92.5	382.8	340.0	374.4	256.8	199.5	666.7	0.17	88.07	87.82	88.31	0.16	88.17	87.87	88.33	0.06
325.0	540.0	0.7	0.0	6.0	0.0	235.9	87.0	93.0	382.3	340.0	374.1	256.7	199.7	669.8	0.17	88.12	87.82	88.30	0.16	88.21	87.87	88.34	0.06
326.0	541.0	0.7	0.0	5.9	0.0	236.1	87.3	93.3	382.2	339.9	373.8	256.7	200.1	673.2	0.17	88.12	87.82	88.32	0.16	88.21	87.90	88.36	0.06
327.0	542.0	0.7	0.0	5.9	0.0	236.6	86.9	93.7	382.1	339.7	373.7	256.4	199.5	675.4	0.17	88.12	87.84	88.35	0.16	88.23	87.91	88.38	0.06
328.0	543.0	0.7	0.0	5.9	0.0	236.9	87.1	92.7	381.3	339.7	373.5	256.0	199.8	675.7	0.17	88.13	87.84	88.34	0.16	88.23	87.92	88.39	0.06
329.0	544.0	0.7	0.0	5.8	0.0	237.0	87.1	92.9	381.1	339.5	373.3	256.2	199.8	675.9	0.17	88.10	87.86	88.34	0.16	88.23	87.95	88.39	0.06
330.0	545.0	0.7	0.0	5.7	0.0	237.1	87.3	93.2	380.7	339.5	373.1	255.9	199.9	675.7	0.17	88.12	87.86	88.33	0.16	88.25	87.94	88.39	0.06
331.0	546.0	0.6	0.0	5.7	0.0	237.0	87.3	92.7	380.4	339.2	372.7	255.7	200.0	675.8	0.17	88.09	87.85	88.33	0.16	88.22	87.94	88.38	0.06
332.0	547.0	0.6	0.0	5.7	0.0	237.1	87.3	92.7	379.8	339.2	372.1	255.3	199.9	677.0	0.17	88.10	87.87	88.37	0.16	88.23	87.95	88.40	0.06
333.0	548.0	0.6	0.0	5.7	0.0	237.4	87.4	92.6	379.7	339.0	371.8	255.1	199.8	678.0	0.17	88.13	87.86	88.36	0.16	88.25	87.96	88.39	0.06
334.0	549.0	0.6	0.0	5.7	0.0	237.6	87.3	92.9	379.4	339.0	371.5	255.1	200.1	678.8	0.17	88.12	87.88	88.35	0.16	88.24	87.96	88.39	0.06
335.0	550.0	0.6	0.0	5.7	0.0	237.7	87.2	92.8	378.9	338.7	371.3	254.9	199.9	679.1	0.17	88.11	87.87	88.35	0.16	88.23	87.96	88.41	0.06
336.0	551.0	0.6	0.0	5.7	0.0	237.7	87.5	93.3	378.5	338.4	370.8	254.5	199.5	679.2	0.17	88.09	87.88	88.36	0.16	88.23	87.96	88.42	0.06
337.0	552.0	0.6	0.0	5.6	0.0	237.7	87.4	92.9	378.2	338.4	370.3	254.3	199.6	679.5	0.17	88.13	87.88	88.38	0.16	88.24	87.96	88.42	0.06
338.0	553.0	0.6	0.0	5.7	0.0	238.0	86.9	93.6	377.6	338.1	370.1	253.9	199.5	682.6	0.17	88.14	87.89	88.39	0.16	88.25	87.98	88.41	0.06
339.0	554.0	0.6	0.0	5.6	0.0	238.7	87.2	93.1	377.0	338.1	369.6	253.9	199.7	686.7	0.17	88.14	87.90	88.39	0.16	88.27	87.98	88.43	0.06
340.0	555.0	0.5	0.0	5.6	0.0	238.8	86.8	93.1	376.6	338.1	369.1	253.6	200.0	690.6	0.17	88.12	87.90	88.39	0.16	88.25	87.98	88.42	0.06
341.0	556.0	0.5	0.0	5.5	0.0	239.1	87.1	93.1	376.2	337.8	368.6	253.3	199.7	691.7	0.17	88.12	87.90	88.41	0.16	88.25	87.99	88.42	0.06
342.0	557.0	0.5	0.0	5.5	0.0	239.4	87.4	93.0	375.6	337.6	368.2	253.1	199.7	692.2	0.17	88.09	87.90	88.41	0.16	88.24	88.00	88.44	0.06
343.0	558.0	0.5	0.0	5.5	0.0	239.5	87.2	92.7	375.1	337.5	367.8	252.9	199.7	691.5	0.17	88.07	87.87	88.41	0.16	88.20	87.97	88.45	0.06
344.0	559.0	0.5	0.0	5.5	0.0	239.4	87.4	93.7	374.6	337.4	367.2	252.8	199.8	690.0	0.17	88.08	87.90	88.43	0.16	88.24	87.99	88.46	0.06
345.0	560.0	0.5	0.0	5.4	0.0	239.4	87.0	92.9	374.3	337.1	366.8	252.7	199.7	687.9	0.17	88.09	87.90	88.42	0.16	88.23	87.99	88.46</	

Manufacturer: HEARTHSTONE
 Model: MANCHESTER

Run: 5
 Project #: P-20174
 Test Duration: 376 min

	HHV	LHV
Eff	75,73%	81,85%
Comb Eff	98,02%	98,02%
HT Eff	77,26%	83,50%
Output	14 851	kJ/h
Burn Rate	0,99	kg/h
Grams CO	217	g
Input	19 612	kJ/h
MC wet	16,59	

Note: In the "Input data", "Calc. % O₂", "Fuel Properties", and "Mass Balance" columns, [e], [d], [g], [a], [b], [c], [h], [u], [w], [j], and [k] refer to their respective variables in Clauses 13.7.3

Ultimate CO₂
 CO_{2-ut} 19,64
 F_o
 1,061

Overall Heating Efficiency: 75,73%
 Combustion Efficiency: 98,02%
 Heat Transfer Efficiency: 77,26%

	Air Fuel Ratio (A/F)
Dry Molecular Weight (M _d)	29,67
Dry Moles Exhaust Gas (N _g):	522,86
Air Fuel Ratio (A/F)	15,00

Heat Output:	14 088 Btu/h	14 851 kJ/h
Heat Input:	18 604 Btu/h	19 612 kJ/h
Burn Duration:	6,27 h	
Burn Rate:	2,18 lb/h	0,990 kg/h
Stack Temp:	273,1 Deg. F	134,0 Deg. C

PRE / POST CHECKS

Date: 2018-08-03 Manufacturer: Hearthstone Model: Marchester
 Project #: PI 20174 Run: 5 Tech: MM Reviewer: JS

Moisture Meter Calibration Check:

Equipment #	Time	12%	22%
<u>EM-191</u>	<u>7:00</u>	<u>ok</u>	<u>ok</u>

Pre-Test

Post-Test

Facility Conditions:

Air Velocity from less than 2 feet
 Smoke Capture Check.....
 Picture.....

Pre-Test	Post-Test
<u>44</u> (max50 Fpm)	<u>43</u> (max50 Fpm)
<u>ok</u>	<u>ok</u>
4 sides <u>ok</u>	<u>ok</u>

Wood Heater Conditions:

Date Wood Heater Stack Cleaned.....
 Date Dilution Tunnel Cleaned.....
 Induced Draft Check (max 0.005 H2O).....
 Traverse before ignition.....
 Flow Rate 140 cfm ±10%.....

<u>2018-07-30</u>
<u>2018-07-30</u>
<u>ok</u>
<u>ok</u>

ok

Temperature System:

Ambient (65°-90°F).....
 Wood Heater Surface (±125°F).....

<u>ok</u>	°F
<u>ok</u>	°F

Proportional Checks:

Thermocouple check.....
 Pitot Clean.....
 Pitot verification.....

<u>ok</u>
<u>ok</u>
<u>ok</u>

Sampling Train ID Numbers:

Probe.....
 Filter Front.....
 Filter Back.....
 Filter Thermocouple.....
 Filter (<90°F).....

Train 1 st hour	Train 1	Train 2
<u>002</u>	<u>21</u>	<u>38</u>
<u>806</u>	<u>808</u>	<u>810</u>
<u>807</u>	<u>809</u>	<u>811</u>
<u>11</u>	<u>11</u>	<u>12</u>
<u>ok</u>	<u>ok</u>	<u>ok</u>

SAMPLING EQUIPMENT CHECK OUT

 Date: 2018-08-03

 Manufacturer: Heathstone

 Model: Manchester

 Project #: OT 20174

 Run: 5

 Tech: mm

 Reviewer: [Signature]
Leakage Checks Tunnel Samplers

Unplugged Flow Rate = .25cfm	System 1 st hour		System 1		System 2	
	Pre-Test ASTM (-15) CSA B415 (-5)	Post-Test (max test)	Pre-Test ASTM (-15) CSA B415 (-5)	Post-Test (Max test)	Pre-Test ASTM (-15) CSA B415 (-5)	Post-Test (Max test)
Vacuum (inches Hg.)	-15	-15	-15	-15	-15	-15
Final 1minute DGM (Liter)	745539.89	747473.89	745540.39	747473.98	699167.04	710086.4
Initial 1minute DGM (Liter)	745539.88	747473.88	745540.39	747473.98	699167.04	710086.4
Change © (Liter)	0.01	0.05	∅	∅	∅	∅
Allowable leakage .04 x Sample rate or 0.28Lpm CSA B415 (0.56)						
Check OK	ok	ok	ok	ok	ok	ok

Leakage Checks Flue Gas Sampler

Plugged Probe	Pre Test	Post Test
Vacuum (inches Hg.)	-5	-5
Rotometer Reading (mml/min.)	0	0
Flow Rate (lpm)	1.5	1.5
Allowable (.02 x Sample Rate)	30	30
Check OK	ok	ok

Leakage Checks Pitot

Plugged Probe	Pre Test 3 H ₂ O static	Pre Test 0.4-0.5 H ₂ O velocity	Post Test 3 H ₂ O Static	Post Test 0.4-0.5 H ₂ O velocity
Vacuum (inches Hg.)	3	.4	3	.4
Check OK (no change after 15 sec.)	ok	ok	ok	ok

PRE-TEST SCALE AUDIT

Date: 2018-08-03 Manufacturer: Health Stone Model: Manchester
 Project #: PT 20174 Run: 5 Tech: MM Reviewer: [Signature]

Scale Type	Audit		Measured Weight
	Equipment #	Weight	
Platform	EM-090	44 lbs, Class F	44 lbs
Wood	EM-090	44 lbs, Class F	44 lbs
Analytical	EM-124	100 mg, Class S	100 mg
Analytical	EM-124	200 g, Class S	200 g

LIMITS OF WEIGHT RANGES

ANALYTICAL SCALE: 50%-150% of dry filter weight, ± 0.1 mg
PLATFORM SCALE: 20%-80% of ideal test load weight, ± 0.1 lbs or 1%
WOOD SCALE: 20%-80% of ideal test load weight, ± 0.01 lbs or 1%

Date: 2018-08-03 Manufacturer: Hearthstone Model: man chest/kh
 Project #: PT 20174 Run: 5 Tech: MM Reviewer: DP

FOR TUNNELS < 12 in

 Barometric pressure (P_{bar}) 101.3 (KPa.) Static pressure (P_q) 0.20 (inches w.c.)
 Inside diameter: Port A _____ Port B _____
 Tunnel cross sectional area: .1963Ft²
 Pitot tube type: Standard

Traverse Point	Position (inches)			Velocity Head Δ_p (inches H ₂ O)	Tunnel Temperature (°F)
	6 po	7 po	8 po		
A - Centroid	3.00	3.50	4	0058	78.50
B - Centroid	3.00	3.50	4	0057	78.69
A-1	0.40	0.50	0.50	0057 0047	78.54
A-2	1.50	1.75	2	0050	78.53
A-3	4.50	5.25	6	0069	78.53
A-4	5.60	6.5	7.5	0048	78.59
B-1	0.40	0.50	0.50	0049	78.54
B-2	1.50	1.75	2	0067	78.54
B-3	4.50	5.25	6	0050	78.57
B-4	5.60	6.5	7.5	0048	78.57
AVERAGE					

$$v_s = K_p C_p (\sqrt{\Delta p})_{avg} \sqrt{\frac{(T_s)_{avg}}{P_s M_s}}$$

Where,

 C_p = pitot tube coefficient, dimension less = 0.99 for standard pitot.

 Δ_p = manometer reading (inches H₂O)

 T_s = average absolute dilution tunnel temperature (°F + 460)

 P_s = absolute dilution tunnel gas pressure or $P_{bar} + P_{qg}$
 P_q = static pressure in. H₂O
 { 13.6 }

 M_s = 28.56, wet molecular weight of stack gas (alternatively, it may be measured)

 K_p = 85.49 pitot tube constant, (conversion factor for English units)

 $(\Delta_p)_{avg}$ = average of the square roots of the velocity heads (Δ_p) measured at each traverse point.

CONTINUOUS ANALYZERS

Date: 2018-08-03 Manufacturer: Hearthstone Model: Manchester
 Project #: PT 20174 Run: 5 Tech: MM Reviewer: [Signature]

Pre-Test (Adjust and Record)

	ZERO		SPAN		CAL. (Record Only)	
	Actual	Should Be	Actual	Should Be	Actual	Should Be
CO	0	0	2,963	3,000	0,997	1,000
Tolerance CO		+/- 0.02		+/- 0.15		+/- 0.05
CO ₂	0	0	17,82	18,00	965	18,00 18,00
Tolerance CO ₂		+/- 0.02		+/- 0.5		+/- 0.5
O ₂ informative CSA B415 calculated value	na	na	na	na	na	na

Post Test (Record Only)

	Zero	Span	Cal.	Zero Drift	Limit	Span Drift	Limit	Cal. Drift	Limit	OK?	Not OK*
CO	0	2985	1.005	0	0.02	0.005	0.15	0.009	0.05	✓	
CO ₂	0	17.95	9.71	0	0.02	0.03	0.5	0.04	0.5	✓	

Date: 2018-08-03 Manufacturer: Heathstone Model: Manchester
 Project #: pJ 20174 Run: 5 Tech: MM Reviewer: DP

RAW DRY GAS METER READINGS

	System 1	System 2	Blank
Final (Liter)	747 416 60	701007, 52	610, 06
Initial (Liter)	745540, 49	699167, 65	471, 16

AMBIENT CONDITIONS

	Before	After
Barometer (kPa):	101, 3	1010
Dry Bulb (F):	80, 63	88, 83
Humidity (%):	53, 5	43, 1

Flow Meter

	Start	End
Flow meter reading	N/A	N/A

Flow Meter Verification

	Before	After
Flow meter Check (liters)	N/A	N/A
Scale Weight (Kg)	N/A	N/A

FUEL DATA

Date: 2018-08-03 Manufacturer: Hearlston Model: Manchester
 Project #: PI 20174 Run: 5 Tech: MM Reviewer: DP

FUEL DESCRIPTION:

Type of wood:

PRE-TEST LOAD

Piece Size	Weight	Meter Moisture Content (% dry)*				
1 1/2 x 3 1/2 x 18 in.	2000 lbs.	214	216	213	213	213
1 1/2 x 3 1/2 x 18 in.	1796 lbs.	221	224	221	218	216
1 1/2 x 3 1/2 x 18 in.	2078 lbs.	219	218	218	217	219
1 1/2 x 3 1/2 x 18 in.	1858 lbs.	220	219	217	218	213
1 1/2 x 3 1/2 x 18 in.	1122 lbs.	209	206	212	211	210
1 1/2 x 3 1/2 x 18 in.	1078 lbs.	208	204	203	219	216
1 1/2 x 3 1/2 x 18 in.	1112 lbs.	220	221	223	223	220
1 1/2 x 3 1/2 x 18 in.	1080 lbs.	213	219	214	218	219
1 1/2 x 3 1/2 x 18 in.	1026 lbs.	214	219	216	213	212
x x in.	lbs.					
1 1/2 x 3 1/2 x 18 in.	1816 lbs.	221	219	213	216	219
1 1/2 x 3 1/2 x 18 in.	1804 lbs.	214	200	199	196	193
1 1/2 x 3 1/2 x 18 in.	3016 lbs.	206	209	207	203	200
1 1/2 x 3 1/2 x 18 in.	1924 lbs.	204	209	203	208	202
1 1/2 x 3 1/2 x 18 in.	1242 lbs.	214	213	219	217	218
1 1/2 x 3 1/2 x 18 in.	1130 lbs.	203	205	206	209	204
1 1/2 x 3 1/2 x 18 in.	0932 lbs.	193	192	192	193	196
1 1/2 x 3 1/2 x 18 in.	1242 lbs.	203	206	205	204	205
1 1/2 x 3 1/2 x 18 in.	1116 lbs.	199	193	199	201	203
x x in.	lbs.					
x x in.	lbs.					
x x in.	lbs.					
x x in.	lbs.					

TEST LOAD WEIGHT: 26,38 lbs

FUEL DATA

 Date: 2018-08-03 Manufacturer: Hearthstone Model: Manchester
 Project #: PT 20174 Run: 5 Tech: MM Reviewer: JP
FUEL DESCRIPTION:

Type of wood :

TEST LOAD

Piece Size	Weight	Meter Moisture Content (% dry)*				
1 1/2 x 3 1/2 x 2.5 in.	216 lbs.	191	196	192	192	193
1 1/2 x 3 1/2 x 2.5 in.	2366 lbs.	195	196	194	193	192
3 1/2 x 3 1/2 x 2.5 in.	5316 lbs.	194	200	203	200	199
3 1/2 x 3 1/2 x 4.5 in.	5228 lbs.	200	206	203	202	200
1 1/2 x 3/4 x 5 in.	0112 lbs.			193		
1 1/2 x 3/4 x 5 in.	0116 lbs.			201		
1 1/2 x 3/4 x 5 in.	0106 lbs.			206		
1 1/2 x 3/4 x 5 in.	0112 lbs.			204		
1 1/2 x 3/4 x 5 in.	0120 lbs.			203		
1 1/2 x 3/4 x 5 in.	0124 lbs.			201		
1 1/2 x 3/4 x 5 in.	0130 lbs.			206		
1 1/2 x 3/4 x 5 in.	0120 lbs.			199		
1 1/2 x 3/4 x 5 in.	0106 lbs.			193		
1 1/2 x 3/4 x 5 in.	0110 lbs.			191		
1 1/2 x 3/4 x 5 in.	0116 lbs.			200		
1 1/2 x 3/4 x 5 in.	0112 lbs.			191		
x x in.	lbs.					
x x in.	lbs.					
x x in.	lbs.					
x x in.	lbs.					
x x in.	lbs.					
x x in.	lbs.					
x x in.	lbs.					
x x in.	lbs.					
x x in.	lbs.					
x x in.	lbs.					
x x in.	lbs.					
x x in.	lbs.					
x x in.	lbs.					

 TEST LOAD WEIGHT: 16413 lbs Min 20%: 329 Max 25%: 410
1646 mm 412 mm

DILUTION TUNNEL PARTICULATE SAMPLER DATA

Date: 2018-08-02 Manufacturer: Heathstork Model: manchester
 Project #: PL20174 Run: 5 Tech: MM Reviewer: NS

		SYSTEM 1 - 1 st hour					SYSTEM 1				
Pre-test Weight Record	Probe & Housing Number	Front Filter Number	Back Filter Number	gaskets	Probe & Housing Number	Front Filter Number	Back Filter Number	gaskets	Back Filter Number	gaskets	Blanc
Date	Time	002	806	807	14	808	809	27	812		
2018-08-01	18:00	611004	01235	01242	34, 3198	108, 7408	0, 1261	0, 1233	34, 1946	0, 1280	
2018-08-03	9:00	611005	01236	01243	34, 3197	108, 7408	0, 1260	0, 1234	34, 1947	0, 1279	

		SYSTEM 1 - 1 st hour					SYSTEM 1				
Post-test Weight Record	Probe & Housing Number	Front Filter Number	Back Filter Number	gaskets	Probe & Housing Number	Front Filter Number	Back Filter Number	gaskets	Back Filter Number	gaskets	Blanc
Date	Time	002	806	807	14	808	809	27	812		
2018-08-03	18:00	611011	01231	01240	34, 3260	108, 7420	0, 1251	0, 1228	34, 2011	0, 1283	
2018-08-08	8:00	611009	01231	01240	34, 3217	108, 7414	0, 1251	0, 1227	34, 1972	0, 1281	
2018-08-09	8:00	611005	01231	01240	34, 3217	108, 7410	0, 1251	0, 1227	34, 1972	0, 1281	
2018-08-09	17:00	611005	01231	01240	34, 3217	108, 7410	0, 1251	0, 1227	34, 1972	0, 1281	



DILUTION TUNNEL PARTICULATE SAMPLER DATA

Date: 2018-08-02 Model: Manchestrik

Manufacturer: Hearthstop

Tech: MR Reviewer: DR

Project #: PI 20174 Run: 5

SYSTEM 2					
Pre-test Weight Record	Probe & Housing Number	Front Filter Number	Back Filter Number	gaskets	
Date	Time	38	810	811	35
2018-08-02	18:00	110.4341	01281	01276	34.0323
2018-08-02	9:00	110.4340	01280	01276	34.0324

SYSTEM 2					
Post-test Weight Record	Probe & Housing Number	Front Filter Number	Back Filter Number	gaskets	
Date	Time	38	810	811	35
2018-08-02	18:00	110.4346	01278	01272	34.0382
2018-08-08	8:00	110.4342	01277	01272	34.0392
2018-08-09	8:00	110.4342	01277	01272	34.0352
2018-08-09	17:00	110.4342	01277	01272	34.0352

APPENDIX 2: Proportionality results

	Outlet	Outlet	Average	Average	#1	#2		
Tunnel	Temp.	Temp.	99,94	99,58	System 1	System 2		SQRT
Velocity	Meter 1	Meter 2	Proportional Rates		Vol.Std.	Vol.Std.		Delta-P
			PR1	PR2			Time	
Ft/Sec	Deg. R	Deg. R	%	%	(ft3)	(ft3)	min	(in H2O)2
16,191	540,6	540,2			0,166	0,163	0	0,2414559
16,035	540,6	540,2	101,13	100,37	0,166	0,163	1	0,2433403
16,052	540,6	540,3	101,09	100,71	0,166	0,162	2	0,2433396
15,989	540,6	540,3	101,90	101,62	0,166	0,163	3	0,2418743
16,105	540,7	540,3	101,56	100,92	0,166	0,163	4	0,2433402
15,982	540,7	540,4	100,78	100,49	0,166	0,163	5	0,2433397
16,007	540,7	540,4	100,24	100,14	0,166	0,163	6	0,243965
15,989	540,7	540,4	99,96	99,93	0,165	0,163	7	0,2439655
15,841	540,7	540,4	100,87	100,52	0,165	0,163	8	0,2418757
15,812	540,7	540,4	101,11	100,67	0,166	0,163	9	0,2414566
15,917	540,7	540,5	100,20	99,75	0,166	0,163	10	0,2433402
16,059	540,7	540,5	99,32	98,92	0,166	0,162	11	0,2454179
15,932	540,7	540,5	100,16	99,78	0,165	0,162	12	0,2433403
16,035	540,7	540,5	99,52	99,19	0,165	0,162	13	0,245003
15,974	540,8	540,6	100,03	99,86	0,166	0,163	14	0,2439657
15,806	540,8	540,6	101,06	100,57	0,166	0,163	15	0,2414566
15,836	540,8	540,6	100,90	100,33	0,166	0,162	16	0,2418757
15,983	540,8	540,6	99,64	99,48	0,165	0,163	17	0,2443808
15,964	540,8	540,6	99,94	99,34	0,165	0,162	18	0,243966
15,919	540,7	540,6	100,04	99,47	0,165	0,162	19	0,24334
15,923	540,7	540,6	100,22	99,88	0,165	0,162	20	0,2433402
15,837	540,7	540,6	100,67	100,32	0,165	0,162	21	0,2418756
15,971	540,8	540,7	99,76	99,55	0,165	0,162	22	0,2439655
15,843	540,8	540,7	100,76	100,51	0,165	0,162	23	0,2418759
15,972	540,9	540,7	99,79	99,64	0,165	0,163	24	0,2439656
15,974	540,9	540,7	99,75	99,62	0,165	0,163	25	0,2439653
16,044	540,9	540,8	99,25	98,98	0,165	0,162	26	0,2450036
15,838	540,9	540,8	100,70	100,32	0,165	0,162	27	0,2418769
15,838	540,9	540,8	100,61	100,32	0,165	0,162	28	0,2418755
16,017	540,9	540,8	99,74	99,30	0,165	0,162	29	0,2443811
15,808	540,9	540,8	100,97	100,85	0,165	0,162	30	0,2414566
15,926	540,9	540,8	99,98	99,79	0,165	0,163	31	0,2433402
16,045	540,9	540,8	99,32	99,09	0,165	0,162	32	0,2450034
15,783	540,9	540,8	101,25	100,64	0,165	0,162	33	0,2408248
15,842	540,9	540,8	100,74	100,60	0,165	0,162	34	0,2418288
15,848	540,9	540,8	100,78	100,32	0,165	0,162	35	0,2418758
15,943	540,9	540,9	99,86	99,63	0,165	0,162	36	0,2433401
15,843	540,9	540,9	100,58	100,37	0,165	0,162	37	0,2418767
15,975	540,9	540,9	99,70	99,37	0,165	0,162	38	0,2439658
15,992	540,9	540,9	99,93	99,65	0,165	0,162	39	0,2439657
16,002	540,9	540,9	99,51	99,15	0,165	0,162	40	0,244381
15,882	541,0	541,0	100,38	100,01	0,165	0,162	41	0,2423563
15,944	541,0	541,0	100,01	99,64	0,165	0,162	42	0,2433405
15,724	541,1	541,0	101,38	100,98	0,165	0,162	43	0,23998
16,003	541,1	541,0	99,51	99,01	0,165	0,162	44	0,24438
16,014	541,1	541,0	99,67	99,35	0,165	0,162	45	0,2443814
15,936	541,1	541,1	99,94	99,58	0,165	0,162	46	0,2433413
16,011	541,1	541,1	99,51	98,94	0,165	0,162	47	0,2443817
15,855	541,1	541,1	100,67	100,06	0,165	0,162	48	0,2418766
15,722	541,2	541,1	101,39	101,16	0,165	0,162	49	0,2399806
16,010	541,2	541,1	99,38	98,97	0,165	0,162	50	0,2443815
15,974	541,2	541,1	100,00	99,59	0,165	0,162	51	0,2433412
15,779	541,2	541,2	101,29	100,85	0,165	0,162	52	0,2404042
16,030	541,2	541,2	99,41	99,09	0,165	0,162	53	0,244382
15,850	541,3	541,2	100,37	100,14	0,165	0,162	54	0,2418764
15,962	541,3	541,2	99,97	99,72	0,165	0,162	55	0,2433414
15,955	541,3	541,2	99,87	99,56	0,165	0,162	56	0,2433415
15,958	541,3	541,3	99,76	99,32	0,165	0,162	57	0,2433413
15,868	541,4	541,3	100,47	100,02	0,164	0,161	58	0,2418767
16,030	541,4	541,3	99,45	98,93	0,165	0,161	59	0,2443823
15,862	541,5	541,4	100,50	100,06	0,165	0,161	60	0,241877
15,871	541,5	541,4	100,57	99,99	0,165	0,161	61	0,2418774
15,853	541,5	541,5	100,48	100,20	0,165	0,162	62	0,2418771

15,966	541,5	541,5	99,87	99,43	0,165	0,162	63	0,2433418
16,031	541,5	541,5	99,34	99,03	0,164	0,162	64	0,2443827
15,875	541,5	541,5	100,50	100,06	0,164	0,162	65	0,2418776
15,954	541,5	541,5	99,84	99,49	0,165	0,162	66	0,2433419
16,034	541,5	541,5	99,37	99,27	0,165	0,162	67	0,2443826
15,964	541,6	541,5	99,79	99,35	0,164	0,162	68	0,2433424
16,077	541,6	541,5	99,19	98,91	0,164	0,162	69	0,2450049
15,961	541,6	541,5	99,77	99,82	0,164	0,162	70	0,2433422
16,014	541,6	541,6	99,57	99,04	0,164	0,162	71	0,2439674
15,883	541,7	541,6	100,51	99,99	0,164	0,161	72	0,2418774
15,965	541,7	541,6	99,84	99,58	0,164	0,161	73	0,2433414
16,017	541,7	541,7	99,67	99,10	0,165	0,161	74	0,2439671
15,874	541,7	541,7	100,38	99,84	0,164	0,161	75	0,2418776
16,139	541,7	541,7	98,88	98,55	0,164	0,161	76	0,2458337
16,046	541,8	541,7	99,35	98,85	0,164	0,161	77	0,2443828
16,014	541,8	541,8	99,54	99,17	0,164	0,161	78	0,2439674
16,043	541,8	541,8	99,30	98,87	0,164	0,161	79	0,2443826
16,007	541,8	541,8	99,49	98,89	0,164	0,161	80	0,2439673
16,039	541,9	541,8	99,27	98,76	0,164	0,161	81	0,2443828
16,005	541,9	541,8	99,21	99,06	0,164	0,161	82	0,2439674
15,876	541,9	541,9	100,11	99,83	0,164	0,161	83	0,2418771
15,984	542,0	541,9	99,69	99,39	0,164	0,161	84	0,2433417
15,983	542,0	541,9	99,73	99,42	0,164	0,161	85	0,2433418
16,079	542,0	541,9	98,87	98,41	0,164	0,161	86	0,2450051
16,041	542,0	541,9	99,39	98,65	0,164	0,161	87	0,2443835
15,879	542,1	542,0	100,13	99,81	0,164	0,161	88	0,2418773
15,974	542,1	542,0	99,64	99,31	0,164	0,161	89	0,2433422
16,082	542,1	542,0	98,93	98,59	0,164	0,161	90	0,2450048
16,009	542,2	542,0	99,36	98,88	0,164	0,161	91	0,2439681
15,876	542,2	542,1	100,17	99,71	0,164	0,161	92	0,2418771
16,080	542,2	542,1	98,78	98,63	0,164	0,161	93	0,2450052
16,079	542,2	542,1	98,86	98,31	0,164	0,161	94	0,2450054
16,033	542,2	542,1	98,98	98,72	0,164	0,161	95	0,2443832
16,057	542,3	542,1	98,67	98,19	0,164	0,161	96	0,2450053
16,005	542,3	542,1	99,07	98,73	0,164	0,161	97	0,2439679
15,647	542,3	542,2	101,49	101,32	0,164	0,161	98	0,238284
15,707	542,3	542,2	100,91	100,66	0,164	0,161	99	0,2393469
15,778	542,4	542,3	100,75	100,24	0,164	0,161	100	0,2404054
15,607	542,4	542,3	101,61	101,23	0,164	0,161	101	0,2378589
15,699	542,4	542,3	100,98	100,55	0,164	0,161	102	0,2393405
15,658	542,4	542,3	101,13	100,76	0,164	0,161	103	0,2389227
15,636	542,5	542,4	101,49	100,98	0,164	0,161	104	0,2382843
15,817	542,6	542,5	99,92	99,57	0,164	0,161	105	0,241459
15,725	542,7	542,5	100,74	100,42	0,164	0,161	106	0,2399825
15,776	542,8	542,6	100,49	100,37	0,164	0,161	107	0,240406
15,742	542,8	542,7	100,62	100,25	0,164	0,161	108	0,2399833
15,655	542,9	542,8	100,89	100,47	0,163	0,160	109	0,2389238
15,622	543,0	542,9	101,19	100,75	0,163	0,160	110	0,2382855
15,804	543,1	542,9	100,15	99,73	0,163	0,160	111	0,2408278
15,737	543,1	543,0	100,31	100,05	0,163	0,160	112	0,2399831
15,617	543,1	543,1	100,76	100,56	0,163	0,160	113	0,238286
15,736	543,2	543,1	100,36	99,95	0,163	0,160	114	0,2399838
15,618	543,2	543,1	101,01	100,62	0,163	0,160	115	0,238286
15,779	543,2	543,1	99,68	99,50	0,163	0,160	116	0,2408284
15,691	543,2	543,2	100,38	100,10	0,163	0,160	117	0,2393488
15,666	543,3	543,2	100,75	100,33	0,163	0,160	118	0,2389247
15,597	543,3	543,3	101,15	100,86	0,163	0,160	119	0,2378609
15,735	543,4	543,3	100,30	100,03	0,163	0,160	120	0,239984
15,682	543,4	543,4	100,54	100,00	0,163	0,160	121	0,2393487
15,777	543,5	543,4	100,13	99,77	0,163	0,160	122	0,2404079
15,740	543,5	543,5	100,11	99,73	0,163	0,160	123	0,2399839
15,731	543,5	543,5	100,21	99,79	0,163	0,160	124	0,239984
15,684	543,6	543,5	100,27	99,94	0,163	0,160	125	0,2393494
15,834	543,6	543,6	99,44	99,08	0,163	0,160	126	0,2414608
15,697	543,8	543,7	100,49	100,01	0,163	0,160	127	0,2393496
15,700	543,8	543,8	100,35	99,87	0,163	0,160	128	0,2393492
15,826	543,9	543,9	99,15	98,73	0,162	0,159	129	0,2414613
15,697	544,0	543,9	100,15	99,98	0,162	0,160	130	0,2393495
15,658	544,0	543,9	100,31	99,84	0,162	0,160	131	0,238925

15,726	543,9	543,9	99,80	99,44	0,162	0,159	132	0,2399844
15,677	544,0	544,0	100,04	99,69	0,162	0,159	133	0,2393491
15,728	544,1	544,0	100,00	99,75	0,163	0,160	134	0,2399847
15,689	544,1	544,1	100,24	99,54	0,163	0,160	135	0,2393494
15,695	544,2	544,2	100,28	99,92	0,163	0,159	136	0,2393499
15,686	544,3	544,3	100,51	100,23	0,163	0,160	137	0,2389258
15,740	544,4	544,4	100,20	99,70	0,163	0,160	138	0,2399845
15,622	544,4	544,4	100,63	100,23	0,163	0,160	139	0,2382874
15,752	544,4	544,4	99,69	99,30	0,162	0,160	140	0,2404081
15,728	544,3	544,4	99,87	99,86	0,162	0,160	141	0,2399859
15,726	544,3	544,4	99,82	99,41	0,162	0,160	142	0,2399856
15,729	544,4	544,4	99,90	99,72	0,162	0,160	143	0,2399861
15,661	544,4	544,5	100,39	99,97	0,163	0,160	144	0,2389264
15,736	544,5	544,5	99,93	99,31	0,163	0,159	145	0,2399854
15,763	544,5	544,5	99,72	99,54	0,162	0,159	146	0,2404085
15,757	544,6	544,6	99,70	99,30	0,162	0,160	147	0,2404094
15,772	544,6	544,6	99,64	99,23	0,162	0,159	148	0,2404085
15,694	544,7	544,7	100,20	99,58	0,162	0,159	149	0,2393505
15,695	544,7	544,7	99,91	99,61	0,162	0,159	150	0,2393506
15,683	544,7	544,7	100,05	99,46	0,162	0,159	151	0,2393502
15,750	544,8	544,8	99,28	99,13	0,162	0,159	152	0,2404088
15,754	544,8	544,8	99,42	98,86	0,162	0,159	153	0,240409
15,751	544,8	544,8	99,31	98,96	0,162	0,159	154	0,2404091
15,620	544,8	544,8	100,22	100,09	0,162	0,159	155	0,2382881
15,727	544,8	544,8	99,64	99,20	0,162	0,159	156	0,2399858
15,560	544,8	544,8	100,78	100,55	0,162	0,159	157	0,2374449
15,775	544,8	544,9	99,28	98,88	0,162	0,159	158	0,2408304
15,774	544,8	544,9	99,24	98,69	0,162	0,159	159	0,2408307
15,718	544,8	544,9	99,62	99,18	0,162	0,159	160	0,2399856
15,843	544,8	544,9	98,78	98,53	0,162	0,159	161	0,2418828
15,736	544,7	544,8	99,33	98,87	0,162	0,159	162	0,2404092
15,933	544,7	544,8	98,11	97,61	0,162	0,159	163	0,2433467
15,687	544,7	544,9	99,89	99,49	0,162	0,159	164	0,2394882
15,718	544,8	544,9	99,54	99,52	0,162	0,159	165	0,2399868
15,632	544,8	544,9	100,45	99,86	0,162	0,159	166	0,2386241
15,607	544,9	544,9	100,49	99,98	0,162	0,159	167	0,2382886
15,674	544,9	545,0	100,11	99,62	0,162	0,159	168	0,2393514
15,762	545,0	545,0	99,54	99,37	0,162	0,159	169	0,2404095
15,748	545,0	545,0	99,37	99,28	0,162	0,160	170	0,2404102
15,674	544,9	545,0	100,02	99,77	0,162	0,160	171	0,2393514
15,670	544,9	545,0	99,87	99,55	0,162	0,160	172	0,2393515
15,715	545,0	545,0	99,67	99,19	0,162	0,159	173	0,2399865
15,647	545,0	545,1	99,98	99,58	0,162	0,159	174	0,2389274
15,715	545,0	545,1	99,45	98,99	0,162	0,159	175	0,2399867
15,741	545,0	545,1	99,21	98,97	0,162	0,159	176	0,2404093
15,670	545,1	545,1	99,74	99,28	0,162	0,159	177	0,2393516
15,573	545,1	545,1	100,43	100,19	0,162	0,159	178	0,2378632
15,811	545,1	545,1	98,97	98,63	0,162	0,159	179	0,2414632
15,738	545,1	545,2	99,31	99,05	0,162	0,159	180	0,2404102
15,773	545,1	545,2	99,20	98,89	0,162	0,159	181	0,2408311
15,744	545,1	545,2	99,38	99,12	0,162	0,159	182	0,2404102
15,645	545,2	545,2	100,00	99,52	0,162	0,159	183	0,2389273
15,741	545,2	545,2	99,33	99,19	0,162	0,159	184	0,24041
15,839	545,2	545,2	98,66	98,31	0,162	0,159	185	0,241883
15,748	545,2	545,2	99,32	98,99	0,162	0,159	186	0,2404102
15,672	545,2	545,3	99,75	99,49	0,162	0,159	187	0,2393513
15,717	545,3	545,3	99,53	99,21	0,162	0,159	188	0,2399869
15,507	545,3	545,3	100,88	100,55	0,162	0,159	189	0,236794
15,716	545,3	545,4	99,52	99,32	0,162	0,159	190	0,2399867
15,739	545,4	545,4	99,42	99,01	0,162	0,159	191	0,24041
15,646	545,4	545,4	100,03	99,72	0,162	0,159	192	0,2389282
15,719	545,5	545,5	99,56	99,41	0,162	0,159	193	0,239987
15,746	545,5	545,5	99,45	99,14	0,162	0,159	194	0,2404104
15,747	545,6	545,6	99,34	99,28	0,162	0,159	195	0,2404101
15,749	545,6	545,6	99,35	99,08	0,162	0,159	196	0,2404097
15,676	545,6	545,6	99,99	99,65	0,162	0,159	197	0,2393521
15,748	545,6	545,7	99,56	99,10	0,162	0,159	198	0,2404101
15,677	545,7	545,7	100,03	99,78	0,162	0,159	199	0,2393522
15,554	545,7	545,7	100,80	100,57	0,162	0,160	200	0,2374362

15,748	545,7	545,7	99,63	99,35	0,162	0,160	201	0,2404108
15,776	545,7	545,8	99,32	98,98	0,162	0,159	202	0,2408318
15,645	545,7	545,8	100,18	99,93	0,162	0,160	203	0,238928
15,681	545,7	545,8	99,99	99,52	0,162	0,159	204	0,2393523
15,782	545,7	545,8	99,63	98,80	0,162	0,159	205	0,2408316
15,681	545,7	545,8	100,21	99,86	0,163	0,159	206	0,239352
15,747	545,7	545,8	99,57	99,14	0,162	0,160	207	0,2404102
15,677	545,7	545,8	99,97	99,97	0,162	0,160	208	0,2393516
15,647	545,7	545,8	100,14	100,12	0,162	0,160	209	0,2389284
15,771	545,7	545,9	99,43	99,20	0,162	0,160	210	0,2408317
15,772	545,8	545,9	99,51	99,15	0,162	0,160	211	0,2408318
15,744	545,8	545,9	99,66	99,02	0,163	0,159	212	0,2404113
15,723	545,8	545,9	99,74	99,23	0,162	0,159	213	0,2399876
15,745	545,8	545,9	99,43	99,14	0,162	0,159	214	0,2404104
15,718	545,7	545,9	100,07	99,89	0,163	0,160	215	0,2399872
15,607	545,7	545,9	100,87	100,47	0,163	0,160	216	0,2382895
15,702	545,7	545,9	99,95	99,71	0,163	0,160	217	0,2398858
15,669	545,7	545,8	100,29	99,88	0,163	0,160	218	0,2393526
15,708	545,7	545,8	100,04	99,60	0,163	0,160	219	0,2399875
15,765	545,7	545,8	99,68	99,14	0,163	0,160	220	0,2408323
15,710	545,7	545,8	100,16	99,66	0,163	0,160	221	0,2399875
15,767	545,6	545,8	99,71	99,33	0,163	0,160	222	0,2408321
15,736	545,6	545,8	99,81	99,49	0,163	0,160	223	0,2404108
15,713	545,6	545,7	100,04	99,59	0,163	0,160	224	0,2399873
15,673	545,6	545,7	100,35	100,10	0,163	0,160	225	0,2393525
15,708	545,6	545,7	99,94	99,86	0,163	0,160	226	0,2399876
15,710	545,5	545,7	100,16	99,52	0,163	0,160	227	0,2399876
15,741	545,5	545,7	100,03	99,59	0,163	0,160	228	0,2404108
15,672	545,5	545,7	100,38	99,87	0,163	0,160	229	0,239352
15,739	545,5	545,7	99,78	99,64	0,163	0,160	230	0,2404109
15,764	545,6	545,7	99,45	99,05	0,163	0,160	231	0,2408321
15,708	545,6	545,7	99,96	99,48	0,163	0,160	232	0,2399867
15,738	545,5	545,7	99,75	99,17	0,163	0,160	233	0,24041
15,595	545,5	545,7	100,74	100,47	0,163	0,160	234	0,2382898
15,642	545,5	545,6	100,40	99,83	0,163	0,160	235	0,2389281
15,665	545,5	545,6	100,40	99,60	0,163	0,160	236	0,2393523
15,666	545,5	545,6	100,18	99,95	0,163	0,160	237	0,2393863
15,706	545,5	545,6	99,92	99,40	0,163	0,160	238	0,2399874
15,764	545,5	545,6	99,69	99,23	0,163	0,160	239	0,2408318
15,759	545,5	545,6	99,73	99,29	0,163	0,160	240	0,240832
15,704	545,4	545,6	99,94	99,64	0,163	0,160	241	0,2399874
15,704	545,4	545,6	100,03	99,69	0,163	0,160	242	0,2399868
15,662	545,4	545,6	100,31	99,94	0,163	0,160	243	0,2393518
15,664	545,4	545,6	100,21	99,86	0,163	0,160	244	0,2393522
15,731	545,4	545,6	99,71	99,47	0,163	0,160	245	0,2404106
15,730	545,4	545,6	99,65	99,66	0,163	0,160	246	0,24041
15,664	545,4	545,6	100,36	99,87	0,163	0,160	247	0,2393521
15,759	545,5	545,6	99,54	99,54	0,163	0,160	248	0,2408318
15,733	545,5	545,6	99,81	99,21	0,163	0,160	249	0,2404105
15,637	545,5	545,6	100,47	99,85	0,163	0,160	250	0,2389278
15,564	545,5	545,6	100,85	100,23	0,163	0,160	251	0,2378642
15,758	545,5	545,6	99,46	99,17	0,163	0,160	252	0,2408319
15,635	545,5	545,6	100,41	100,17	0,163	0,160	253	0,2389281
15,664	545,5	545,6	100,43	99,84	0,163	0,160	254	0,2393519
15,735	545,5	545,6	99,79	99,41	0,163	0,160	255	0,2404102
15,665	545,5	545,6	100,22	99,70	0,163	0,160	256	0,2393522
15,642	545,5	545,6	100,48	100,13	0,163	0,160	257	0,2389283
15,619	545,5	545,7	100,62	100,02	0,163	0,160	258	0,2385709
15,707	545,6	545,7	99,97	99,72	0,163	0,160	259	0,2399888
15,738	545,5	545,7	99,81	99,73	0,163	0,160	260	0,2404111
15,575	545,5	545,7	100,96	100,77	0,163	0,160	261	0,2378644
15,734	545,5	545,7	99,97	99,53	0,163	0,160	262	0,2404113
15,766	545,5	545,7	99,45	99,24	0,163	0,160	263	0,2408324
15,670	545,6	545,7	100,32	99,69	0,163	0,160	264	0,2393526
15,672	545,6	545,7	100,16	99,78	0,163	0,160	265	0,2393833
15,665	545,6	545,7	100,36	99,81	0,163	0,160	266	0,2393523
15,593	545,6	545,7	100,62	100,28	0,163	0,160	267	0,2382897
15,665	545,6	545,7	100,30	99,82	0,163	0,160	268	0,2393524
15,735	545,6	545,7	99,84	99,22	0,163	0,160	269	0,2404108

15,704	545,6	545,8	99,94	99,51	0,163	0,160	270	0,2399874
15,733	545,7	545,8	99,65	99,20	0,163	0,160	271	0,240411
15,703	545,7	545,8	99,84	99,53	0,163	0,160	272	0,239988
15,702	545,7	545,8	99,93	99,46	0,163	0,160	273	0,2399878
15,763	545,7	545,8	99,42	99,21	0,163	0,160	274	0,2408322
15,661	545,7	545,8	100,16	99,76	0,163	0,160	275	0,2393524
15,729	545,7	545,8	99,62	99,39	0,163	0,160	276	0,2404103
15,726	545,7	545,8	99,53	99,35	0,163	0,160	277	0,2404106
15,759	545,6	545,8	99,43	98,72	0,163	0,159	278	0,2408322
15,730	545,6	545,7	99,49	99,06	0,162	0,159	279	0,240411
15,737	545,6	545,7	99,84	99,31	0,163	0,160	280	0,2404109
15,596	545,6	545,7	100,51	99,98	0,163	0,160	281	0,2382898
15,703	545,6	545,7	99,62	99,22	0,162	0,159	282	0,2399696
15,634	545,6	545,7	100,10	99,92	0,162	0,160	283	0,2389282
15,927	545,6	545,7	98,42	98,14	0,162	0,160	284	0,2433476
15,664	545,6	545,7	100,21	99,79	0,163	0,160	285	0,2393527
15,704	545,6	545,8	99,75	99,60	0,163	0,160	286	0,2399874
15,708	545,7	545,8	99,88	99,34	0,163	0,160	287	0,2399875
15,733	545,6	545,8	99,70	99,69	0,163	0,160	288	0,2404111
15,710	545,6	545,8	99,61	99,35	0,162	0,160	289	0,2399873
15,668	545,6	545,8	100,02	99,56	0,162	0,159	290	0,2393524
15,565	545,6	545,8	100,62	100,34	0,162	0,160	291	0,2378641
15,760	545,6	545,8	99,25	99,02	0,162	0,160	292	0,2408321
15,702	545,6	545,8	99,65	99,41	0,162	0,160	293	0,2399876
15,706	545,7	545,8	99,75	99,35	0,162	0,160	294	0,2399875
15,734	545,7	545,8	99,58	99,30	0,163	0,160	295	0,2404111
15,737	545,7	545,8	99,53	99,28	0,162	0,160	296	0,2404107
15,638	545,7	545,8	100,20	99,67	0,162	0,159	297	0,238928
15,738	545,7	545,8	99,51	99,41	0,162	0,160	298	0,2404105
15,760	545,7	545,8	99,50	99,21	0,163	0,160	299	0,2408322
15,731	545,7	545,8	99,52	99,00	0,163	0,160	300	0,2404108
15,755	545,7	545,8	99,23	99,15	0,162	0,160	301	0,2408322
15,665	545,7	545,8	100,01	99,69	0,162	0,160	302	0,2393524
15,803	545,7	545,8	99,20	98,79	0,163	0,160	303	0,2414643
15,732	545,7	545,8	99,39	99,11	0,162	0,160	304	0,240411
15,760	545,7	545,8	99,38	98,92	0,162	0,159	305	0,2408316
15,666	545,7	545,8	100,03	99,54	0,162	0,159	306	0,2393704
15,637	545,7	545,8	100,21	99,97	0,163	0,160	307	0,2389287
15,641	545,7	545,8	100,27	99,70	0,163	0,160	308	0,2389286
15,598	545,7	545,8	100,60	100,06	0,163	0,159	309	0,2382902
15,671	545,8	545,9	100,00	99,83	0,163	0,160	310	0,2393524
15,672	545,8	545,9	100,04	99,57	0,162	0,160	311	0,2393523
15,643	545,8	545,9	100,33	100,07	0,163	0,160	312	0,2389284
15,643	545,8	546,0	100,35	99,89	0,163	0,160	313	0,2389283
15,716	545,8	546,0	99,90	99,39	0,163	0,160	314	0,2399881
15,643	545,9	546,0	100,34	99,98	0,163	0,160	315	0,2389283
15,772	545,9	546,0	99,57	99,30	0,163	0,160	316	0,2408319
15,747	545,9	546,0	99,66	99,34	0,163	0,160	317	0,2404108
15,718	545,9	546,1	99,88	99,48	0,163	0,160	318	0,2399876
15,675	546,0	546,1	100,10	99,90	0,163	0,160	319	0,2393522
15,739	546,0	546,1	99,69	99,30	0,163	0,160	320	0,2404112
15,507	546,0	546,1	101,16	100,84	0,163	0,160	321	0,236795
15,815	546,0	546,1	99,12	98,75	0,162	0,160	322	0,2414646
15,675	546,0	546,1	100,02	99,67	0,162	0,159	323	0,2393531
15,673	546,0	546,2	99,90	99,67	0,162	0,160	324	0,239353
15,758	546,1	546,2	99,71	99,34	0,162	0,160	325	0,2404116
15,749	546,1	546,2	99,61	99,07	0,162	0,159	326	0,2404116
15,781	546,1	546,3	99,47	98,96	0,162	0,159	327	0,240833
15,756	546,2	546,3	99,59	99,27	0,162	0,159	328	0,2404112
15,778	546,2	546,3	99,44	98,86	0,162	0,159	329	0,2408328
15,653	546,3	546,4	100,13	99,55	0,162	0,159	330	0,2389292
15,818	546,3	546,4	99,03	98,71	0,162	0,159	331	0,2414645
15,729	546,3	546,4	99,59	99,32	0,162	0,159	332	0,239988
15,654	546,3	546,4	99,97	99,88	0,162	0,159	333	0,2389289
15,783	546,3	546,4	99,36	99,02	0,162	0,159	334	0,2408052
15,752	546,3	546,4	99,62	99,24	0,162	0,159	335	0,2404113
15,820	546,3	546,4	98,92	98,61	0,162	0,159	336	0,2414649
15,679	546,3	546,5	99,95	99,51	0,162	0,159	337	0,2393486
15,777	546,3	546,5	99,28	99,22	0,162	0,159	338	0,2408329

15,723	546,3	546,5	99,65	99,17	0,162	0,159	339	0,2399884
15,776	546,4	546,5	99,22	98,90	0,162	0,159	340	0,2408326
15,817	546,4	546,5	99,20	98,73	0,162	0,159	341	0,2414649
15,776	546,4	546,5	99,25	98,97	0,162	0,159	342	0,2408327
15,679	546,4	546,5	99,90	99,41	0,162	0,159	343	0,2393535
15,773	546,4	546,5	99,25	98,93	0,162	0,159	344	0,240833
15,650	546,4	546,5	100,05	99,71	0,162	0,159	345	0,2389291
15,748	546,4	546,6	99,42	99,02	0,162	0,159	346	0,2404116
15,746	546,4	546,6	99,40	98,94	0,162	0,159	347	0,2404117
15,721	546,4	546,6	99,61	99,41	0,162	0,159	348	0,2399883
15,818	546,5	546,6	98,94	98,46	0,162	0,159	349	0,2414653
15,744	546,5	546,6	99,26	98,83	0,162	0,159	350	0,2404132
15,745	546,5	546,6	99,41	99,08	0,162	0,159	351	0,2404117

	Outlet	Outlet	Average	Average	#1	#2		
Tunnel	Temp.	Temp.	97,16	97,55	System 1	System 2		SQRT
Velocity	Meter 1	Meter 2	Proportional Rates		Vol.Std.	Vol.Std.		Delta-P
			PR1	PR2			Time	
Ft/Sec	Deg. R	Deg. R	%	%	(ft3)	(ft3)	min	(in H2O)2
16,341	542,9	542,5			0,162	0,159	0	0,2468643
16,174	542,9	542,5	97,08	97,62	0,162	0,159	1	0,2458338
16,165	542,9	542,5	97,50	97,91	0,162	0,159	2	0,2454798
16,266	542,9	542,5	97,36	97,57	0,162	0,159	3	0,2464531
16,123	542,9	542,6	98,35	98,56	0,162	0,159	4	0,243969
16,183	542,9	542,6	96,69	97,18	0,162	0,159	5	0,2464529
16,208	542,9	542,6	96,47	97,15	0,162	0,159	6	0,246864
16,290	542,8	542,6	95,93	96,15	0,162	0,159	7	0,2485042
16,236	542,8	542,6	96,01	96,19	0,162	0,159	8	0,2478904
16,041	542,8	542,6	97,13	97,52	0,162	0,159	9	0,2450064
16,125	542,8	542,6	96,35	96,57	0,162	0,159	10	0,2464533
16,197	542,8	542,6	96,00	96,41	0,162	0,159	11	0,2474804
16,221	542,8	542,6	95,98	96,42	0,162	0,159	12	0,2478904
16,214	542,8	542,6	95,88	96,09	0,162	0,159	13	0,2478908
16,216	542,8	542,7	95,90	96,33	0,162	0,159	14	0,2478905
16,247	542,8	542,6	95,55	96,03	0,162	0,159	15	0,2485039
16,305	542,8	542,6	95,25	95,67	0,162	0,159	16	0,24932
16,186	542,8	542,6	95,97	96,55	0,162	0,159	17	0,2474803
16,201	542,8	542,7	95,88	96,16	0,162	0,159	18	0,2478123
16,205	542,9	542,7	95,75	96,23	0,162	0,159	19	0,247891
16,149	542,9	542,7	96,22	96,47	0,162	0,159	20	0,2468648
16,188	542,9	542,7	95,97	96,43	0,162	0,159	21	0,2474802
16,254	542,9	542,7	95,61	95,90	0,162	0,159	22	0,2485039
16,119	542,9	542,7	96,32	96,85	0,162	0,159	23	0,2464529
16,299	542,9	542,7	95,18	95,75	0,162	0,159	24	0,2493195
16,218	542,9	542,7	95,52	96,06	0,162	0,159	25	0,2481944
16,168	542,9	542,7	95,92	96,07	0,162	0,159	26	0,2474805
16,298	543,0	542,7	95,31	95,61	0,162	0,159	27	0,2493192
16,113	543,0	542,8	96,46	96,75	0,162	0,159	28	0,246453
16,147	543,0	542,7	96,28	96,80	0,162	0,159	29	0,2468644
16,228	543,0	542,8	96,02	96,32	0,162	0,159	30	0,2478912
16,183	543,0	542,8	96,00	96,38	0,162	0,159	31	0,2474799
16,256	543,0	542,8	95,64	96,05	0,162	0,159	32	0,2485035
16,260	543,0	542,8	95,72	96,04	0,162	0,159	33	0,2485038
16,214	543,0	542,8	95,91	95,97	0,162	0,159	34	0,2478904
16,191	542,9	542,8	95,89	96,21	0,162	0,158	35	0,2474803
16,186	543,0	542,8	96,02	96,26	0,162	0,159	36	0,2474799
16,157	543,0	542,8	96,28	96,59	0,162	0,159	37	0,2468646
16,180	543,0	542,8	95,97	96,27	0,162	0,159	38	0,2474805
16,209	543,0	542,8	95,79	96,15	0,162	0,159	39	0,2478903
16,196	543,1	542,9	96,03	96,27	0,162	0,159	40	0,2474801
16,094	543,1	543,0	96,70	97,20	0,162	0,159	41	0,2458343
16,095	543,2	543,0	96,76	97,00	0,162	0,159	42	0,2458339
16,149	543,3	543,1	96,57	96,89	0,162	0,159	43	0,2464535
16,178	543,3	543,1	96,30	96,98	0,162	0,159	44	0,2468643
16,150	543,3	543,1	96,51	97,08	0,162	0,159	45	0,2464539
16,115	543,4	543,2	96,67	97,12	0,161	0,159	46	0,2458357
16,160	543,4	543,2	96,58	97,05	0,162	0,159	47	0,2464532
16,158	543,5	543,3	96,62	96,94	0,162	0,159	48	0,2464538
16,165	543,5	543,3	96,62	96,89	0,162	0,159	49	0,246454
16,195	543,6	543,4	96,46	96,74	0,162	0,159	50	0,2468647
16,067	543,6	543,4	97,08	97,56	0,162	0,159	51	0,2450077
16,102	543,7	543,5	96,98	97,54	0,161	0,159	52	0,2454215
16,011	543,7	543,5	97,47	97,75	0,161	0,159	53	0,24397
16,140	543,7	543,6	96,87	97,34	0,161	0,159	54	0,2458347
16,087	543,8	543,6	97,35	97,67	0,162	0,159	55	0,2450074

16,183	543,8	543,7	96,64	96,94	0,162	0,159	56	0,2464546
16,189	543,9	543,7	96,63	97,13	0,161	0,159	57	0,2464541
16,096	543,9	543,8	97,42	97,62	0,162	0,159	58	0,2450076
16,218	544,0	543,8	96,63	96,97	0,162	0,159	59	0,2468643
16,110	544,0	543,9	97,03	97,36	0,162	0,159	60	0,2454228
16,153	544,0	543,9	96,92	97,32	0,162	0,159	61	0,2458819
16,130	544,1	544,0	97,08	97,43	0,161	0,159	62	0,2454227
16,226	544,1	544,0	96,38	96,91	0,161	0,159	63	0,2469335
16,223	544,2	544,1	96,41	96,86	0,161	0,159	64	0,2468654
16,199	544,2	544,1	96,68	96,99	0,161	0,158	65	0,2464546
16,199	544,3	544,1	96,73	97,15	0,161	0,159	66	0,2464548
16,039	544,3	544,2	97,73	98,21	0,161	0,159	67	0,243971
16,200	544,3	544,2	96,74	97,18	0,161	0,159	68	0,2464548
16,337	544,4	544,2	95,93	96,15	0,161	0,159	69	0,2485049
16,232	544,4	544,3	96,50	97,02	0,161	0,158	70	0,2468657
16,204	544,4	544,3	96,68	97,17	0,161	0,159	71	0,2464551
16,161	544,5	544,4	96,94	97,48	0,161	0,159	72	0,2458357
16,207	544,5	544,4	96,65	97,08	0,161	0,159	73	0,2464552
16,163	544,5	544,4	96,94	97,43	0,161	0,159	74	0,2458357
16,160	544,6	544,4	96,93	97,09	0,161	0,158	75	0,2458359
16,213	544,6	544,5	96,75	97,09	0,161	0,158	76	0,2464553
16,214	544,6	544,5	96,72	97,05	0,161	0,158	77	0,2464549
16,144	544,7	544,6	97,22	97,42	0,161	0,158	78	0,2454234
16,206	544,7	544,6	96,59	96,79	0,161	0,158	79	0,2464552
16,111	544,7	544,6	97,18	97,36	0,161	0,158	80	0,2450088
16,233	544,7	544,7	96,33	96,85	0,161	0,158	81	0,24686
16,280	544,8	544,7	96,26	96,46	0,161	0,158	82	0,2474826
16,240	544,8	544,7	96,37	96,63	0,161	0,158	83	0,2468662
16,121	544,8	544,8	97,07	97,50	0,161	0,158	84	0,2450092
16,217	544,9	544,8	96,53	96,86	0,161	0,158	85	0,2464558
16,278	544,9	544,8	96,17	96,43	0,161	0,158	86	0,2474824
16,215	544,9	544,9	96,59	96,95	0,161	0,158	87	0,2464558
16,231	545,0	544,9	96,29	96,60	0,161	0,158	88	0,2468665
16,253	545,0	544,9	96,15	96,47	0,161	0,158	89	0,2472621
16,202	545,0	544,9	96,37	96,81	0,161	0,158	90	0,2464666
16,285	544,9	544,9	95,66	96,10	0,161	0,158	91	0,247893
16,191	544,9	544,9	96,35	96,82	0,161	0,158	92	0,2464556
16,179	544,9	544,9	96,58	97,09	0,161	0,158	93	0,2458363
16,302	544,9	544,8	95,85	96,17	0,161	0,158	94	0,2478938
16,157	545,0	544,9	96,57	97,02	0,161	0,158	95	0,2458368
16,202	544,9	544,8	96,37	96,87	0,161	0,158	96	0,2464558
16,198	544,9	544,8	96,27	96,68	0,161	0,158	97	0,2464556
16,214	544,9	544,8	96,35	96,88	0,161	0,158	98	0,2464559
16,346	544,9	544,9	95,46	96,09	0,161	0,158	99	0,2485068
16,309	544,9	544,9	95,84	96,15	0,161	0,158	100	0,247894
16,171	544,9	544,9	96,61	97,09	0,161	0,158	101	0,2458365
16,274	544,9	544,9	95,88	96,20	0,161	0,158	102	0,2474829
16,201	544,9	544,9	96,24	96,73	0,161	0,158	103	0,2464563
16,115	544,9	544,8	96,94	97,36	0,161	0,158	104	0,24501
16,161	544,9	544,8	96,47	97,24	0,161	0,158	105	0,2458369
16,105	544,9	544,8	96,91	97,35	0,161	0,158	106	0,2450099
16,202	544,9	544,8	96,17	96,90	0,161	0,158	107	0,2464561
16,211	545,0	544,8	96,31	96,48	0,161	0,158	108	0,2464558
16,258	545,0	544,8	95,88	96,14	0,161	0,158	109	0,2474836
16,128	545,0	544,9	96,53	97,13	0,161	0,158	110	0,2454243
16,283	545,0	544,9	95,57	95,89	0,161	0,158	111	0,2478935
15,976	545,1	544,9	97,36	97,85	0,161	0,158	112	0,2433462
15,888	545,0	544,9	98,04	98,40	0,161	0,158	113	0,241882
15,888	545,0	544,9	98,01	98,50	0,161	0,158	114	0,2418821
15,866	545,1	544,9	98,26	98,71	0,161	0,158	115	0,2414628
15,887	545,1	545,0	98,03	98,48	0,161	0,158	116	0,241882

15,701	545,1	545,0	99,22	99,62	0,161	0,158	117	0,2389256
15,813	545,1	545,0	98,17	98,82	0,160	0,158	118	0,240831
15,801	545,2	545,0	98,59	99,03	0,160	0,158	119	0,2404096
15,975	545,2	545,1	97,31	97,70	0,161	0,158	120	0,2433467
15,888	545,2	545,1	97,79	98,12	0,160	0,158	121	0,2418822
15,881	545,3	545,1	97,92	98,30	0,160	0,158	122	0,2418826
15,854	545,3	545,2	98,10	98,54	0,161	0,158	123	0,2414628
15,798	545,4	545,3	98,58	98,81	0,161	0,158	124	0,2404095
15,989	545,5	545,3	97,31	97,77	0,161	0,158	125	0,2433471
15,821	545,5	545,4	98,25	98,78	0,160	0,158	126	0,2408313
15,831	545,6	545,4	98,32	98,70	0,160	0,158	127	0,2408312
15,841	545,6	545,5	98,43	98,73	0,160	0,157	128	0,2408313
15,705	545,7	545,6	99,03	99,57	0,160	0,158	129	0,2389276
16,046	545,8	545,6	97,08	97,27	0,160	0,157	130	0,2439729
15,992	545,8	545,7	97,30	97,74	0,160	0,157	131	0,2433475
15,827	545,9	545,8	98,30	98,58	0,160	0,157	132	0,2408318
15,828	545,9	545,8	98,26	98,73	0,160	0,157	133	0,2408316
16,000	546,0	545,9	97,38	97,60	0,160	0,157	134	0,2433476
15,895	546,0	546,0	97,88	98,24	0,160	0,157	135	0,2418833
15,729	546,0	546,0	98,91	99,16	0,160	0,157	136	0,2393523
15,989	546,0	546,0	97,25	97,68	0,160	0,157	137	0,2433473
15,831	546,0	546,0	98,37	98,65	0,160	0,158	138	0,2408319
15,986	546,0	546,1	97,28	97,62	0,160	0,157	139	0,243348
15,762	546,1	546,1	98,54	99,06	0,160	0,158	140	0,2399864
15,860	546,1	546,1	97,89	98,42	0,160	0,158	141	0,2414635
15,764	546,1	546,1	98,44	99,16	0,160	0,158	142	0,2399877
15,867	546,2	546,2	98,00	98,39	0,160	0,158	143	0,2414651
15,823	546,3	546,3	98,21	98,65	0,160	0,157	144	0,2408322
15,892	546,4	546,3	97,77	98,16	0,160	0,157	145	0,2418837
15,891	546,5	546,4	97,93	98,19	0,160	0,157	146	0,2418791
15,825	546,5	546,5	98,16	98,62	0,160	0,157	147	0,2408318
15,909	546,6	546,5	97,80	98,35	0,160	0,158	148	0,2420499
15,994	546,7	546,6	97,17	97,63	0,160	0,158	149	0,2433481
15,995	546,8	546,7	97,17	97,40	0,160	0,157	150	0,2433482
15,989	546,9	546,8	97,02	97,47	0,160	0,157	151	0,2433488
15,894	547,0	546,9	97,61	97,99	0,160	0,157	152	0,2418847
15,838	547,0	546,9	98,11	98,50	0,160	0,157	153	0,2408329
15,874	547,0	547,0	97,81	98,15	0,160	0,157	154	0,2414646
15,869	547,1	547,0	97,71	98,12	0,160	0,157	155	0,2414641
15,870	547,1	547,0	97,64	98,48	0,160	0,157	156	0,2414651
15,766	547,1	547,1	98,28	98,53	0,160	0,157	157	0,2399886
15,987	547,1	547,1	96,96	97,51	0,160	0,157	158	0,243349
16,023	547,1	547,1	96,59	96,89	0,160	0,157	159	0,2439748
15,723	547,0	547,0	98,67	98,84	0,160	0,157	160	0,2393543
15,861	547,0	547,0	97,68	98,01	0,160	0,157	161	0,2414657
15,986	547,1	547,1	97,01	97,30	0,160	0,157	162	0,2433494
15,814	547,1	547,1	97,92	98,26	0,160	0,157	163	0,240834
15,985	547,1	547,1	96,97	97,35	0,160	0,157	164	0,24335
15,820	547,2	547,2	97,90	98,30	0,160	0,157	165	0,2408336
15,862	547,2	547,2	97,55	98,04	0,160	0,157	166	0,2414656
15,884	547,3	547,2	97,39	97,73	0,160	0,157	167	0,2418854
15,858	547,3	547,3	97,49	97,98	0,160	0,157	168	0,2414662
15,883	547,3	547,3	97,29	97,81	0,160	0,157	169	0,2418853
15,852	547,3	547,3	97,49	97,90	0,160	0,157	170	0,2414656
15,783	547,3	547,3	97,99	98,29	0,160	0,157	171	0,2404124
15,884	547,3	547,3	97,43	97,89	0,160	0,157	172	0,2418855
15,885	547,3	547,3	97,41	97,66	0,160	0,157	173	0,2418862
15,879	547,3	547,4	97,29	97,70	0,160	0,157	174	0,2418856
15,816	547,3	547,4	97,84	98,06	0,160	0,157	175	0,240834
15,785	547,3	547,4	97,86	98,19	0,160	0,157	176	0,2404735
15,975	547,4	547,4	96,83	97,13	0,160	0,157	177	0,2433499

15,584	547,4	547,4	99,13	99,50	0,160	0,157	178	0,2374386
15,884	547,4	547,4	97,34	97,78	0,160	0,157	179	0,2418853
15,976	547,4	547,5	96,70	97,24	0,160	0,157	180	0,2433504
15,848	547,4	547,5	97,53	97,87	0,160	0,157	181	0,2414664
15,706	547,4	547,5	98,33	98,82	0,160	0,157	182	0,2393548
15,808	547,4	547,5	97,73	97,99	0,160	0,157	183	0,2408851
15,847	547,4	547,5	97,37	97,66	0,160	0,157	184	0,2414666
15,883	547,4	547,5	97,23	97,53	0,159	0,157	185	0,2418861
15,876	547,4	547,5	97,24	97,55	0,160	0,157	186	0,2418856
15,844	547,4	547,5	97,40	97,95	0,160	0,157	187	0,2414665
15,846	547,4	547,5	97,46	97,80	0,160	0,157	188	0,2414663
15,806	547,5	547,6	97,66	98,25	0,160	0,157	189	0,2408347
15,852	547,5	547,6	97,49	97,60	0,160	0,157	190	0,241467
15,878	547,5	547,6	97,38	97,78	0,160	0,157	191	0,241886
15,788	547,6	547,6	98,04	98,39	0,160	0,157	192	0,2404136
15,877	547,6	547,6	97,29	97,57	0,160	0,157	193	0,2418865
15,809	547,6	547,7	97,60	98,31	0,160	0,157	194	0,2408344
15,744	547,6	547,7	97,92	98,34	0,159	0,157	195	0,2399892
15,867	547,6	547,7	97,23	97,49	0,160	0,157	196	0,2418862
15,804	547,5	547,6	97,61	98,07	0,160	0,157	197	0,2408345
15,874	547,5	547,6	97,31	97,62	0,160	0,157	198	0,2418862
15,807	547,5	547,6	97,72	97,93	0,160	0,157	199	0,2408349
15,718	547,5	547,7	98,37	98,66	0,160	0,157	200	0,239355
15,799	547,5	547,7	97,63	98,16	0,160	0,157	201	0,240835
15,844	547,5	547,6	97,40	98,00	0,160	0,157	202	0,2414635
15,777	547,5	547,6	97,88	98,05	0,160	0,157	203	0,2404142
15,802	547,5	547,6	97,77	98,00	0,160	0,157	204	0,2408348
15,973	547,5	547,7	96,62	97,13	0,160	0,157	205	0,2433506
15,849	547,6	547,7	97,45	97,77	0,160	0,157	206	0,2414676
15,853	547,6	547,7	97,41	97,91	0,160	0,157	207	0,2414683
15,872	547,6	547,7	97,33	97,54	0,160	0,157	208	0,2418863
15,845	547,6	547,7	97,32	97,82	0,160	0,157	209	0,2414668
15,974	547,6	547,7	96,69	97,05	0,160	0,157	210	0,2433509
15,976	547,6	547,7	96,71	97,17	0,160	0,157	211	0,2433506
15,846	547,5	547,7	97,50	97,80	0,160	0,157	212	0,2414668
15,974	547,6	547,7	96,74	97,25	0,160	0,157	213	0,2433509
15,762	547,6	547,8	98,10	98,58	0,160	0,157	214	0,2399898
15,883	547,7	547,8	97,37	97,82	0,160	0,157	215	0,2418866
15,858	547,7	547,8	97,61	98,00	0,160	0,157	216	0,2414668
15,814	547,7	547,8	97,66	98,24	0,160	0,157	217	0,240835
15,854	547,8	547,8	97,42	98,15	0,159	0,157	218	0,2414669
15,880	547,8	547,9	97,27	97,67	0,160	0,157	219	0,2418859
15,818	547,8	547,9	97,75	98,44	0,160	0,157	220	0,2408344
15,854	547,8	547,9	97,54	97,82	0,160	0,157	221	0,2414667
16,049	547,9	548,0	96,21	96,64	0,160	0,157	222	0,2443919
15,813	547,9	548,0	97,62	97,87	0,159	0,157	223	0,2408354
15,816	547,9	548,0	97,73	98,19	0,159	0,157	224	0,2408351
15,978	547,9	548,0	96,70	96,99	0,160	0,157	225	0,243351
15,890	547,9	548,0	97,24	97,47	0,159	0,156	226	0,2418866
15,858	547,9	548,0	97,22	97,50	0,159	0,156	227	0,2414669
15,886	547,9	548,0	97,19	97,24	0,159	0,156	228	0,2418869
15,690	547,9	548,0	98,34	98,76	0,159	0,156	229	0,2389315
15,982	547,9	548,1	96,60	96,94	0,159	0,156	230	0,2433511
16,019	548,0	548,1	96,13	96,80	0,159	0,157	231	0,243977
15,980	548,0	548,1	96,52	96,87	0,159	0,157	232	0,2433517
16,026	548,0	548,1	96,28	96,66	0,159	0,156	233	0,243977
15,988	548,1	548,2	96,56	96,84	0,159	0,156	234	0,2433516
15,886	548,1	548,2	97,19	97,46	0,159	0,156	235	0,2418869
15,978	548,1	548,2	96,50	96,84	0,159	0,156	236	0,2433514
15,822	548,2	548,2	97,52	97,99	0,159	0,156	237	0,2408353
15,992	548,2	548,3	96,59	96,74	0,159	0,156	238	0,2433511

15,817	548,3	548,3	97,66	97,81	0,159	0,156	239	0,2408355
15,820	548,3	548,4	97,52	97,96	0,159	0,156	240	0,2408354
16,054	548,4	548,5	96,10	96,38	0,159	0,156	241	0,2443922
15,858	548,4	548,5	97,20	97,76	0,159	0,156	242	0,2414686
15,974	548,4	548,5	96,51	96,98	0,159	0,157	243	0,243352
15,888	548,4	548,5	97,04	97,59	0,159	0,157	244	0,2418873
15,980	548,5	548,6	96,53	96,95	0,159	0,157	245	0,2433518
15,859	548,5	548,6	97,17	97,59	0,159	0,156	246	0,2414679
16,024	548,5	548,6	96,19	96,39	0,159	0,156	247	0,243977
15,864	548,5	548,6	97,21	97,66	0,159	0,156	248	0,241468
15,892	548,5	548,6	97,26	97,59	0,159	0,156	249	0,2418878
16,054	548,5	548,6	96,07	96,39	0,159	0,156	250	0,2443931
15,864	548,6	548,7	97,32	97,64	0,159	0,156	251	0,2414681
15,988	548,6	548,7	96,57	96,99	0,159	0,156	252	0,2433518
16,032	548,6	548,7	96,31	96,76	0,159	0,156	253	0,2439775
15,865	548,7	548,8	97,39	98,03	0,159	0,157	254	0,2414676
15,994	548,7	548,8	96,59	96,99	0,159	0,157	255	0,243352
15,826	548,7	548,8	97,61	98,07	0,159	0,156	256	0,240836
16,033	548,8	548,9	96,20	96,87	0,159	0,157	257	0,2439777
15,898	548,8	548,9	97,31	97,59	0,159	0,157	258	0,2418872
15,826	548,9	549,0	97,77	97,96	0,159	0,156	259	0,2408182
15,828	548,9	549,0	97,72	97,83	0,159	0,156	260	0,2408365
15,870	548,9	549,0	97,28	97,63	0,159	0,156	261	0,2414689
15,899	549,0	549,1	97,31	97,60	0,159	0,156	262	0,2418874
16,060	549,0	549,1	96,17	96,68	0,159	0,157	263	0,2443934
15,991	549,0	549,1	96,68	96,90	0,159	0,156	264	0,2433525
15,995	549,1	549,1	96,63	97,18	0,159	0,157	265	0,2433521
15,891	549,0	549,1	97,23	97,61	0,159	0,157	266	0,241888
15,862	549,0	549,1	97,31	97,91	0,159	0,157	267	0,2414684
15,892	549,0	549,1	97,16	97,52	0,159	0,157	268	0,2418886
15,797	549,0	549,1	97,84	98,04	0,159	0,156	269	0,2404152
15,865	549,0	549,1	97,34	97,76	0,159	0,156	270	0,2414685
15,986	548,9	549,1	96,50	97,05	0,159	0,157	271	0,2433525
16,030	549,0	549,1	96,32	96,66	0,159	0,156	272	0,2439779
16,027	549,0	549,1	96,35	96,75	0,159	0,156	273	0,243978
15,892	549,0	549,1	97,30	97,62	0,159	0,157	274	0,2418882
15,987	549,0	549,1	96,63	97,14	0,159	0,157	275	0,2433532
15,888	549,0	549,1	97,27	97,42	0,159	0,157	276	0,241894
15,990	549,0	549,1	96,65	97,00	0,159	0,156	277	0,243353
15,797	548,9	549,1	97,94	98,22	0,159	0,157	278	0,2404152
15,889	549,0	549,1	97,19	97,61	0,159	0,157	279	0,2418888
15,891	549,0	549,1	97,47	97,78	0,160	0,157	280	0,2418879
15,889	548,9	549,1	97,30	97,61	0,160	0,157	281	0,2418881
15,864	548,9	549,1	97,41	97,90	0,159	0,157	282	0,2414681
15,817	548,9	549,1	97,60	97,94	0,159	0,157	283	0,2408366
15,885	548,9	549,1	97,04	97,57	0,159	0,156	284	0,2418885
15,818	548,9	549,1	97,63	98,08	0,159	0,157	285	0,2408366
15,862	548,9	549,1	97,48	97,73	0,159	0,157	286	0,2414828
15,861	548,9	549,1	97,36	97,84	0,159	0,157	287	0,241469
15,885	548,9	549,0	97,06	97,63	0,159	0,157	288	0,2418883
15,859	548,8	549,0	97,45	97,91	0,159	0,157	289	0,2414684
15,982	548,8	549,0	96,63	97,19	0,159	0,157	290	0,2433526
16,050	548,8	549,0	96,22	96,71	0,159	0,157	291	0,2443936
15,786	548,8	549,0	97,80	98,18	0,159	0,157	292	0,2404149
15,881	548,8	549,0	97,19	97,59	0,159	0,157	293	0,2418881
15,810	548,8	549,0	97,63	98,12	0,159	0,157	294	0,2408363
15,784	548,8	549,0	97,93	98,02	0,160	0,157	295	0,2404153
16,015	548,8	549,0	96,43	96,65	0,160	0,156	296	0,2439779
15,881	548,8	549,0	97,27	97,73	0,160	0,157	297	0,2418881
15,881	548,8	548,9	97,18	97,87	0,159	0,157	298	0,2418886
15,854	548,8	548,9	97,45	97,92	0,159	0,157	299	0,241469

15,979	548,8	548,9	96,64	97,17	0,160	0,157	300	0,2433525
15,854	548,8	548,9	97,38	97,87	0,159	0,157	301	0,2414683
15,851	548,8	548,9	97,43	97,82	0,160	0,157	302	0,2414685
15,712	548,8	548,9	98,28	98,72	0,160	0,157	303	0,2393571
16,013	548,7	548,9	96,53	96,64	0,160	0,157	304	0,2439778
15,827	548,7	548,9	97,46	97,87	0,160	0,157	305	0,2411869
15,879	548,7	548,9	97,21	97,66	0,159	0,157	306	0,2418853
15,820	548,7	548,9	97,84	98,26	0,160	0,157	307	0,2408359
16,046	548,7	548,9	96,36	96,54	0,160	0,157	308	0,244393
16,093	548,8	548,9	96,16	96,47	0,160	0,157	309	0,2450152
15,859	548,8	548,9	97,44	97,92	0,160	0,157	310	0,2414677
16,049	548,8	548,9	96,22	96,70	0,159	0,157	311	0,2443926
16,020	548,8	549,0	96,34	96,60	0,159	0,157	312	0,2439771
15,883	548,8	548,9	97,32	97,64	0,159	0,157	313	0,2418883
15,882	548,8	549,0	97,29	97,77	0,160	0,157	314	0,2418878
15,982	548,8	548,9	96,77	96,96	0,160	0,157	315	0,2433523
15,865	548,8	548,9	97,54	98,21	0,160	0,157	316	0,2414684
15,888	548,8	548,9	97,37	97,32	0,160	0,157	317	0,241888
15,993	548,8	549,0	96,64	97,38	0,159	0,157	318	0,243352
15,889	548,9	549,0	97,29	97,56	0,159	0,157	319	0,2418878
16,054	548,9	549,0	96,11	96,57	0,159	0,156	320	0,2443928
16,017	548,9	549,0	96,49	96,75	0,159	0,157	321	0,2439779
15,877	548,9	549,0	97,22	97,56	0,160	0,157	322	0,241888
15,838	548,9	549,0	97,55	97,81	0,160	0,157	323	0,2412964
15,851	548,9	549,0	97,51	97,81	0,160	0,157	324	0,2414682
15,781	548,9	549,0	97,86	98,22	0,160	0,157	325	0,240415
16,049	548,9	549,0	96,31	96,59	0,160	0,157	326	0,2443932
15,855	548,9	549,0	97,57	97,83	0,160	0,157	327	0,2414685
15,856	548,9	549,0	97,52	97,94	0,160	0,157	328	0,2414684
15,852	549,0	549,0	97,42	97,92	0,160	0,157	329	0,2414687
15,894	549,0	549,0	97,33	97,68	0,160	0,157	330	0,241888
15,889	549,0	549,0	97,34	97,72	0,160	0,157	331	0,2418883
15,860	549,0	549,1	97,52	97,72	0,160	0,157	332	0,2414691
15,885	549,0	549,1	97,26	97,62	0,160	0,157	333	0,2418888
15,861	549,0	549,1	97,46	97,76	0,160	0,157	334	0,2414687
15,983	549,0	549,1	96,80	97,00	0,160	0,157	335	0,2433525
15,985	549,0	549,1	96,77	97,04	0,160	0,157	336	0,2433527
15,890	549,0	549,1	97,30	97,87	0,160	0,157	337	0,2418884
16,096	549,0	549,1	96,25	96,39	0,160	0,157	338	0,2450155
15,795	549,1	549,1	97,97	98,40	0,160	0,157	339	0,2404152
15,983	549,1	549,2	96,71	97,23	0,160	0,157	340	0,2433523
15,824	549,1	549,2	97,94	98,18	0,160	0,157	341	0,2408364
15,818	549,1	549,2	98,01	98,48	0,160	0,157	342	0,2408368
15,984	549,1	549,2	97,07	97,34	0,160	0,157	343	0,2433529
15,763	549,1	549,2	98,53	98,75	0,160	0,157	344	0,2399779
15,891	549,1	549,2	97,71	98,15	0,160	0,157	345	0,2418883
15,822	549,1	549,2	98,19	98,58	0,160	0,157	346	0,2408365
16,027	549,2	549,2	96,80	97,21	0,160	0,157	347	0,2439781
15,824	549,2	549,3	98,20	98,48	0,160	0,157	348	0,2408362
15,893	549,2	549,3	97,72	97,93	0,160	0,157	349	0,2418878
15,798	549,2	549,3	98,32	98,63	0,160	0,157	350	0,2404155
15,866	549,2	549,3	97,87	98,21	0,160	0,157	351	0,241469
15,825	549,2	549,3	98,32	98,57	0,160	0,157	352	0,2408365
15,768	549,2	549,3	98,59	98,92	0,160	0,157	353	0,2399923
16,033	549,2	549,3	96,87	97,48	0,160	0,158	354	0,2439783
15,889	549,2	549,3	97,82	97,97	0,160	0,157	355	0,2418326
15,990	549,2	549,3	97,05	97,51	0,160	0,157	356	0,2433523
15,823	549,2	549,3	98,17	98,70	0,160	0,157	357	0,2408367
15,989	549,3	549,3	97,12	97,70	0,160	0,158	358	0,2433529
15,864	549,3	549,4	97,82	98,20	0,160	0,157	359	0,241469
15,863	549,3	549,3	97,86	98,28	0,160	0,157	360	0,2414694

15,987	549,3	549,4	97,27	97,51	0,160	0,157	361	0,2433534
15,893	549,3	549,4	97,69	98,12	0,160	0,157	362	0,2418884
15,822	549,3	549,3	98,15	98,55	0,160	0,157	363	0,2408366
15,866	549,3	549,3	97,88	98,14	0,160	0,157	364	0,2414686
15,795	549,3	549,3	98,54	98,83	0,160	0,157	365	0,240415
15,990	549,3	549,4	97,26	97,57	0,160	0,157	366	0,2433524
16,028	549,3	549,4	96,90	97,35	0,160	0,157	367	0,2439778
15,865	549,3	549,4	98,01	98,01	0,160	0,157	368	0,2414681
15,821	549,3	549,4	98,19	98,44	0,160	0,157	369	0,2408366
15,862	549,3	549,4	98,01	98,25	0,160	0,157	370	0,2414686
15,823	549,3	549,4	98,26	98,61	0,160	0,157	371	0,2408363
15,985	549,3	549,4	97,06	97,45	0,160	0,157	372	0,2433529
16,029	549,3	549,4	96,89	97,30	0,160	0,157	373	0,2439781
15,863	549,2	549,4	97,97	98,19	0,160	0,157	374	0,2414686
15,891	549,2	549,4	97,68	98,14	0,160	0,157	375	0,241888
15,891	549,2	549,4	97,57	97,97	0,160	0,157	376	0,241888
15,890	549,2	549,4	97,63	98,20	0,160	0,157	377	0,2418882
15,792	549,2	549,4	98,31	98,49	0,160	0,157	378	0,2404153
15,795	549,2	549,4	98,40	98,66	0,160	0,157	379	0,2404154
15,822	549,2	549,4	98,27	98,48	0,160	0,157	380	0,2408367
15,986	549,3	549,4	97,05	97,29	0,160	0,157	381	0,2433526
15,821	549,2	549,4	98,28	98,63	0,160	0,157	382	0,2408363
15,861	549,2	549,4	97,99	98,36	0,160	0,158	383	0,2414686
15,892	549,2	549,3	97,82	98,18	0,160	0,157	384	0,2418878
15,790	549,2	549,3	98,29	98,62	0,160	0,157	385	0,240415
15,888	549,2	549,3	97,82	98,10	0,160	0,157	386	0,2418885
15,792	549,2	549,3	98,26	98,75	0,160	0,157	387	0,2404153
15,860	549,2	549,3	97,70	98,25	0,160	0,157	388	0,2414688
15,861	549,2	549,3	97,95	98,10	0,160	0,157	389	0,2414703
16,025	549,2	549,3	96,86	97,34	0,160	0,157	390	0,2439778
15,887	549,2	549,3	97,80	98,23	0,160	0,158	391	0,2418882
15,790	549,2	549,3	98,31	98,60	0,160	0,157	392	0,2404159
15,886	549,2	549,3	97,71	98,01	0,160	0,157	393	0,2418883
15,859	549,2	549,3	97,85	98,25	0,160	0,157	394	0,2414684
15,887	549,2	549,3	97,66	98,16	0,160	0,157	395	0,241888
15,887	549,2	549,3	97,69	98,08	0,160	0,157	396	0,2418884

	Outlet	Outlet	Average	Average	#1	#2		
Tunnel	Temp.	Temp.	99,13	97,45	System 1	System 2		SQRT
Velocity	Meter 1	Meter 2	Proportional Rates		Vol.Std.	Vol.Std.		Delta-P
			PR1	PR2			Time	
Ft/Sec	Deg. R	Deg. R	%	%	(ft3)	(ft3)	min	(in H2O)2
16,398	546,9	546,6			0,158	0,155	0	0,243975
16,128	546,8	546,6	100,81	99,40	0,158	0,155	1	0,2414652
16,272	546,8	546,5	100,28	98,47	0,158	0,155	2	0,243349
16,335	546,7	546,5	100,09	98,18	0,158	0,155	3	0,2439742
16,389	546,7	546,5	100,34	98,60	0,158	0,155	4	0,2441885
16,181	546,7	546,5	100,85	99,08	0,158	0,155	5	0,2418844
16,314	546,7	546,5	99,67	97,93	0,158	0,155	6	0,2443895
16,288	546,7	546,5	99,89	98,13	0,158	0,155	7	0,2439742
16,299	546,7	546,5	99,43	97,79	0,158	0,155	8	0,2443901
16,312	546,7	546,5	99,74	97,92	0,158	0,155	9	0,2443896
16,263	546,7	546,5	99,69	98,02	0,158	0,155	10	0,243974
16,233	546,7	546,5	100,02	98,42	0,158	0,155	11	0,2433492
16,348	546,7	546,5	99,35	97,74	0,158	0,155	12	0,2450117
16,374	546,6	546,5	99,03	97,45	0,158	0,155	13	0,2453466
16,398	546,6	546,4	99,32	97,89	0,158	0,155	14	0,2454264
16,385	546,6	546,4	99,26	97,51	0,158	0,155	15	0,2454262
16,412	546,6	546,4	99,38	97,54	0,158	0,155	16	0,2454261
16,176	546,6	546,4	100,62	99,05	0,158	0,155	17	0,2421872
16,309	546,6	546,4	99,99	98,28	0,158	0,155	18	0,2439739
16,308	546,6	546,4	99,89	98,33	0,158	0,155	19	0,2439738
16,373	546,6	546,4	99,64	97,60	0,158	0,155	20	0,2450112
16,377	546,6	546,4	99,56	97,79	0,158	0,155	21	0,2450113
16,403	546,6	546,4	99,30	97,68	0,158	0,155	22	0,2454261
16,298	546,6	546,4	100,06	98,12	0,158	0,155	23	0,2438962
16,338	546,6	546,4	99,87	98,05	0,158	0,155	24	0,2443909
16,399	546,6	546,4	99,59	98,05	0,158	0,155	25	0,2450114
16,286	546,6	546,4	100,34	98,67	0,158	0,155	26	0,2433482
16,365	546,6	546,5	100,09	98,32	0,158	0,155	27	0,2443888
16,328	546,6	546,5	100,02	98,42	0,158	0,155	28	0,2439738
16,322	546,7	546,5	99,78	98,16	0,158	0,155	29	0,2439738
16,183	546,7	546,5	100,80	99,33	0,158	0,155	30	0,2418839
16,407	546,7	546,5	99,67	98,07	0,158	0,155	31	0,2450109
16,300	546,7	546,6	100,31	98,65	0,158	0,155	32	0,2433483
16,347	546,7	546,6	100,18	98,35	0,158	0,155	33	0,2439737
16,134	546,7	546,6	101,40	99,62	0,158	0,155	34	0,2408324
16,337	546,8	546,6	99,89	98,52	0,158	0,155	35	0,2439732
16,339	546,8	546,6	100,14	98,53	0,158	0,155	36	0,2439739
16,298	546,8	546,7	100,40	98,66	0,158	0,155	37	0,2433481
16,430	546,9	546,7	99,43	97,85	0,158	0,155	38	0,2454259
16,348	546,8	546,7	100,08	98,52	0,158	0,155	39	0,243973
16,201	546,9	546,7	101,03	99,34	0,158	0,155	40	0,2418854
16,361	546,9	546,7	99,89	98,18	0,158	0,155	41	0,2443892
16,409	546,9	546,7	99,64	97,88	0,158	0,155	42	0,2450108
16,296	546,9	546,8	100,23	98,71	0,158	0,155	43	0,2433481
16,361	546,9	546,8	99,90	98,12	0,158	0,155	44	0,244389
16,336	546,9	546,8	100,07	98,37	0,158	0,155	45	0,2439738
16,330	547,0	546,8	100,04	98,14	0,158	0,155	46	0,2439737
16,374	547,0	546,8	99,94	98,13	0,158	0,155	47	0,2443889
16,356	547,0	546,8	99,62	98,26	0,158	0,155	48	0,2443948
16,302	547,0	546,8	100,45	98,66	0,158	0,155	49	0,2433486
16,358	547,1	546,9	99,85	98,28	0,158	0,155	50	0,2443889
16,361	547,1	546,9	99,88	98,25	0,158	0,155	51	0,2443895
16,284	547,1	546,9	100,19	98,56	0,158	0,155	52	0,2433487
16,180	547,1	546,9	100,76	98,91	0,158	0,155	53	0,2418838
16,393	547,1	546,9	99,62	97,72	0,158	0,155	54	0,2449813
16,186	547,2	547,0	100,72	99,11	0,158	0,155	55	0,2418843

16,285	547,1	547,0	100,27	98,45	0,158	0,155	56	0,243349
16,402	547,1	547,0	99,56	97,92	0,158	0,155	57	0,2450116
16,328	547,2	547,0	99,93	98,22	0,158	0,155	58	0,2439742
16,363	547,2	547,0	99,78	98,27	0,158	0,155	59	0,2443893
16,347	547,2	547,1	99,74	97,97	0,158	0,155	60	0,2443901
16,293	547,2	547,1	100,22	98,76	0,158	0,155	61	0,243349
16,354	547,2	547,1	99,72	98,17	0,158	0,155	62	0,2443892
16,189	547,2	547,1	100,80	99,22	0,158	0,155	63	0,2419068
16,452	547,3	547,1	99,14	97,65	0,158	0,155	64	0,2458392
16,390	547,3	547,1	99,52	97,94	0,158	0,155	65	0,2450117
16,355	547,3	547,1	99,91	98,27	0,158	0,155	66	0,2443899
16,303	547,3	547,1	99,83	98,06	0,158	0,155	67	0,2439742
16,334	547,3	547,1	99,63	97,83	0,158	0,155	68	0,2443896
16,377	547,3	547,2	99,41	97,67	0,158	0,155	69	0,2450117
16,262	547,3	547,2	100,07	98,46	0,158	0,155	70	0,2433489
16,364	547,3	547,2	99,36	97,73	0,158	0,155	71	0,2450118
16,304	547,3	547,2	99,83	98,26	0,158	0,155	72	0,2439745
16,408	547,3	547,2	99,23	97,86	0,158	0,155	73	0,2454263
16,334	547,3	547,2	99,73	98,13	0,158	0,155	74	0,2443898
16,396	547,3	547,2	99,11	97,40	0,158	0,155	75	0,2454267
16,430	547,3	547,2	99,07	97,40	0,158	0,155	76	0,2458393
16,389	547,3	547,2	99,21	97,62	0,158	0,155	77	0,2454268
16,158	547,3	547,2	100,69	98,84	0,158	0,155	78	0,2418774
16,374	547,4	547,2	99,42	97,71	0,158	0,155	79	0,2450117
16,422	547,4	547,2	99,03	97,48	0,158	0,155	80	0,2458384
16,287	547,4	547,2	99,65	97,98	0,158	0,155	81	0,2439746
16,285	547,4	547,3	99,64	98,05	0,158	0,155	82	0,2439709
16,148	547,4	547,3	100,65	98,85	0,158	0,155	83	0,2418852
16,346	547,4	547,3	99,28	97,34	0,158	0,155	84	0,2450125
16,313	547,4	547,3	99,57	97,95	0,158	0,155	85	0,2443902
16,408	547,4	547,3	98,97	97,27	0,158	0,155	86	0,2458397
16,299	547,4	547,3	99,51	97,58	0,158	0,155	87	0,2443903
16,368	547,4	547,3	99,03	97,24	0,158	0,155	88	0,2454147
16,374	547,5	547,3	99,03	97,49	0,158	0,155	89	0,2454269
16,388	547,4	547,3	98,94	97,33	0,158	0,155	90	0,2456849
16,274	547,4	547,3	99,64	98,05	0,158	0,155	91	0,2439746
16,333	547,5	547,3	99,08	97,21	0,158	0,155	92	0,245012
16,285	547,4	547,3	99,64	97,86	0,158	0,155	93	0,2439748
16,337	547,4	547,3	99,20	97,56	0,158	0,155	94	0,2450121
16,364	547,5	547,3	99,02	97,36	0,158	0,155	95	0,2454271
16,385	547,4	547,3	98,85	97,27	0,158	0,155	96	0,2458396
16,349	547,4	547,3	98,77	97,18	0,158	0,155	97	0,2454269
16,207	547,4	547,3	99,81	98,09	0,158	0,155	98	0,2433495
16,326	547,4	547,3	99,01	97,42	0,158	0,155	99	0,245012
16,364	547,4	547,3	98,60	97,04	0,158	0,155	100	0,2458392
16,341	547,4	547,3	98,95	97,26	0,158	0,155	101	0,2454266
16,245	547,4	547,2	99,48	97,70	0,158	0,155	102	0,2439747
16,326	547,4	547,2	98,76	97,15	0,158	0,155	103	0,2454263
16,328	547,4	547,2	98,61	97,15	0,158	0,155	104	0,245427
16,324	547,4	547,2	98,88	97,10	0,158	0,155	105	0,2454273
16,312	547,4	547,2	98,63	97,11	0,158	0,155	106	0,2454267
16,207	547,4	547,2	99,30	97,71	0,158	0,155	107	0,2439746
16,270	547,4	547,3	98,90	97,08	0,158	0,155	108	0,2450122
16,269	547,4	547,3	98,94	97,03	0,158	0,155	109	0,2450117
16,221	547,4	547,3	99,01	97,33	0,158	0,155	110	0,2443901
16,316	547,4	547,3	98,45	96,54	0,158	0,155	111	0,245756
16,224	547,5	547,3	99,01	97,24	0,158	0,155	112	0,2443918
16,288	547,5	547,4	98,55	96,87	0,158	0,155	113	0,2454271
16,286	547,5	547,4	98,45	97,10	0,158	0,155	114	0,2454266
16,253	547,6	547,4	98,73	96,73	0,158	0,155	115	0,2450126
16,349	547,6	547,5	98,12	96,35	0,158	0,155	116	0,246459

16,283	547,6	547,5	98,55	96,76	0,158	0,155	117	0,2454272
16,213	547,6	547,5	98,88	97,50	0,158	0,155	118	0,2443901
16,140	547,6	547,5	99,33	97,38	0,158	0,155	119	0,2433496
16,249	547,6	547,5	98,54	97,04	0,158	0,155	120	0,2450128
16,283	547,6	547,6	98,54	96,65	0,158	0,155	121	0,2454268
16,309	547,6	547,6	98,32	96,49	0,158	0,155	122	0,2458403
16,254	547,6	547,6	98,74	96,83	0,158	0,155	123	0,245013
16,249	547,6	547,6	98,55	97,36	0,158	0,155	124	0,2450125
16,275	547,6	547,6	98,43	96,77	0,158	0,155	125	0,2454274
16,326	547,7	547,6	98,25	96,49	0,158	0,155	126	0,2461885
16,206	547,7	547,6	98,99	97,35	0,158	0,155	127	0,2443908
16,205	547,7	547,6	98,91	97,29	0,158	0,155	128	0,2443908
16,275	547,7	547,6	98,49	96,70	0,158	0,155	129	0,2454273
16,136	547,7	547,7	99,35	97,71	0,158	0,155	130	0,2433495
16,133	547,7	547,7	99,24	97,67	0,158	0,155	131	0,2433497
16,276	547,7	547,7	98,46	96,94	0,158	0,155	132	0,2454276
16,202	547,8	547,7	98,69	96,99	0,158	0,155	133	0,2443904
16,271	547,8	547,7	98,38	96,66	0,158	0,155	134	0,2454279
16,246	547,8	547,7	98,53	96,95	0,158	0,155	135	0,2450124
16,175	547,8	547,7	99,07	97,37	0,158	0,155	136	0,2439752
16,271	547,8	547,8	98,52	96,72	0,158	0,155	137	0,2454231
16,175	547,9	547,8	99,03	97,20	0,158	0,155	138	0,2439758
16,202	547,9	547,8	98,73	97,22	0,158	0,155	139	0,244391
16,269	547,9	547,8	98,40	96,68	0,158	0,155	140	0,2454277
16,244	548,0	547,8	98,58	96,75	0,158	0,155	141	0,2450134
16,297	548,0	547,8	98,11	96,71	0,158	0,155	142	0,2458409
16,204	548,0	547,8	98,86	97,25	0,158	0,155	143	0,2443914
16,203	548,0	547,9	98,77	97,19	0,158	0,155	144	0,2443922
16,205	548,0	547,9	98,72	97,16	0,158	0,155	145	0,2443913
16,299	548,0	547,9	98,25	96,51	0,158	0,155	146	0,2458411
16,134	547,9	547,9	99,21	97,41	0,158	0,155	147	0,2433508
16,204	547,9	547,9	98,74	97,06	0,158	0,155	148	0,2443915
16,247	547,9	547,9	98,46	96,72	0,158	0,155	149	0,2450272
16,298	547,9	547,9	98,28	96,53	0,158	0,155	150	0,2458405
16,273	547,9	547,9	98,50	96,67	0,158	0,155	151	0,2454285
16,301	548,0	547,9	98,24	96,69	0,158	0,155	152	0,2458415
16,271	548,0	547,9	98,46	96,62	0,158	0,155	153	0,2454279
16,272	548,0	547,9	98,52	97,07	0,158	0,155	154	0,2454451
16,341	548,0	548,0	98,08	96,26	0,158	0,155	155	0,2464602
16,273	548,0	548,0	98,44	96,90	0,158	0,155	156	0,2454285
16,247	548,0	548,0	98,66	97,16	0,158	0,155	157	0,2450136
16,342	548,0	548,0	97,99	96,53	0,158	0,155	158	0,2464582
16,138	548,0	548,0	99,41	97,48	0,158	0,155	159	0,2433514
16,204	548,1	548,0	98,74	97,28	0,158	0,155	160	0,2443918
16,175	548,1	548,0	98,91	97,11	0,158	0,155	161	0,2439763
16,200	548,1	548,1	98,72	96,95	0,158	0,155	162	0,2443912
16,270	548,1	548,1	98,41	96,54	0,158	0,155	163	0,2454289
16,243	548,1	548,1	98,53	97,00	0,158	0,155	164	0,2450146
16,200	548,1	548,1	98,91	97,09	0,158	0,155	165	0,2443917
16,169	548,1	548,1	98,96	97,30	0,158	0,155	166	0,2439765
16,197	548,1	548,1	98,85	97,14	0,158	0,155	167	0,2443922
16,296	548,1	548,1	98,23	96,46	0,158	0,155	168	0,2458413
16,242	548,1	548,1	98,45	97,11	0,158	0,155	169	0,2450145
16,270	548,1	548,1	98,45	96,60	0,158	0,155	170	0,2454287
16,173	548,1	548,1	98,90	97,41	0,158	0,155	171	0,243977
16,297	548,1	548,1	98,26	96,38	0,158	0,155	172	0,2458413
16,296	548,1	548,1	98,31	96,65	0,158	0,155	173	0,2458418
16,269	548,1	548,1	98,41	96,54	0,158	0,155	174	0,2454288
16,269	548,2	548,1	98,30	96,79	0,158	0,155	175	0,2454286
16,244	548,2	548,2	98,42	96,94	0,158	0,155	176	0,2450137
16,204	548,2	548,2	98,85	97,05	0,158	0,155	177	0,2443922

16,205	548,2	548,2	98,83	97,19	0,158	0,155	178	0,244392
16,176	548,3	548,2	98,93	97,23	0,158	0,155	179	0,2439769
16,272	548,3	548,3	98,30	96,61	0,158	0,155	180	0,245428
16,246	548,3	548,3	98,72	96,94	0,158	0,155	181	0,2450145
16,178	548,4	548,3	99,01	97,43	0,158	0,155	182	0,2439768
16,137	548,4	548,3	99,11	97,52	0,158	0,155	183	0,2433511
16,300	548,4	548,4	98,16	96,38	0,158	0,155	184	0,2458416
16,246	548,5	548,4	98,34	96,95	0,158	0,155	185	0,2450143
16,247	548,5	548,4	98,46	96,84	0,158	0,155	186	0,2450142
16,013	548,5	548,4	100,04	98,23	0,158	0,155	187	0,2414664
16,301	548,5	548,5	98,21	96,50	0,158	0,155	188	0,2458411
16,279	548,5	548,5	98,47	96,81	0,158	0,155	189	0,2454287
16,210	548,6	548,5	98,85	96,85	0,158	0,155	190	0,244392
16,251	548,6	548,6	98,53	96,81	0,158	0,155	191	0,2450142
16,184	548,6	548,6	98,91	97,53	0,158	0,155	192	0,2439759
16,142	548,7	548,6	99,03	97,39	0,157	0,155	193	0,2433515
16,185	548,7	548,7	99,01	97,22	0,158	0,155	194	0,2439763
16,285	548,8	548,7	98,54	96,72	0,158	0,155	195	0,2454282
16,286	548,8	548,7	98,45	96,65	0,158	0,155	196	0,2454291
16,214	548,8	548,8	98,89	96,95	0,158	0,155	197	0,2443918
15,980	548,9	548,8	100,40	98,64	0,158	0,155	198	0,2408354
16,259	548,9	548,9	98,64	96,89	0,158	0,155	199	0,2450139
16,287	549,0	548,9	98,31	96,87	0,158	0,155	200	0,2454288
16,288	549,0	548,9	98,33	96,81	0,158	0,155	201	0,2454295
16,193	549,0	549,0	99,00	97,12	0,158	0,155	202	0,2439774
16,218	549,0	549,0	98,78	97,14	0,158	0,155	203	0,2443928
16,260	549,1	549,0	98,59	96,89	0,158	0,155	204	0,2450149
16,257	549,1	549,0	98,56	97,01	0,158	0,155	205	0,2450149
16,049	549,0	549,0	99,84	98,26	0,158	0,155	206	0,2418877
16,256	549,0	549,0	98,49	96,74	0,158	0,155	207	0,245015
16,213	549,1	549,0	98,70	97,09	0,158	0,155	208	0,2443928
16,254	549,1	549,0	98,47	96,74	0,158	0,155	209	0,245015
16,142	549,0	549,0	99,24	97,41	0,158	0,155	210	0,2433522
16,277	549,0	549,0	98,44	96,61	0,158	0,155	211	0,2454298
16,304	549,0	549,0	98,23	96,48	0,158	0,155	212	0,2458427
16,250	549,0	549,0	98,53	97,11	0,158	0,155	213	0,2450151
16,209	549,0	548,9	98,79	97,00	0,158	0,155	214	0,2443936
16,179	549,0	548,9	99,00	96,92	0,158	0,155	215	0,2439778
16,275	549,0	548,9	98,31	96,80	0,158	0,155	216	0,2454299
16,209	549,0	548,9	98,76	97,16	0,158	0,155	217	0,2443934
16,247	548,9	548,9	98,53	96,86	0,158	0,155	218	0,2450154
15,970	548,9	548,9	100,20	98,43	0,158	0,155	219	0,2408369
16,148	548,9	548,9	99,15	97,60	0,158	0,155	220	0,2435493
16,200	548,9	548,8	98,70	97,02	0,158	0,155	221	0,244393
16,205	548,9	548,8	98,69	97,03	0,158	0,155	222	0,2444658
16,200	548,9	548,8	98,81	97,15	0,158	0,155	223	0,2443934
16,129	548,8	548,8	99,18	97,41	0,158	0,155	224	0,2433524
16,130	548,8	548,8	99,21	97,43	0,158	0,155	225	0,2433539
16,197	548,8	548,8	98,80	97,15	0,158	0,155	226	0,2443932
16,128	548,8	548,8	99,24	97,52	0,158	0,155	227	0,2433528
16,360	548,8	548,8	97,78	96,07	0,158	0,155	228	0,2468732
16,167	548,8	548,7	98,85	97,38	0,158	0,155	229	0,2439777
16,198	548,8	548,8	98,65	97,22	0,158	0,155	230	0,2443934
16,362	548,8	548,7	97,65	96,16	0,158	0,155	231	0,2468735
16,198	548,8	548,7	98,70	97,23	0,158	0,155	232	0,2443934
16,196	548,7	548,7	98,58	97,14	0,158	0,155	233	0,2443928
16,268	548,7	548,7	98,27	96,64	0,158	0,155	234	0,2454296
16,238	548,7	548,7	98,56	96,99	0,158	0,155	235	0,2450148
16,266	548,7	548,7	98,22	96,62	0,158	0,155	236	0,2454295
16,236	548,7	548,7	98,44	96,56	0,158	0,155	237	0,245015
16,194	548,7	548,7	98,68	96,95	0,158	0,155	238	0,244393

16,330	548,7	548,7	97,91	96,21	0,158	0,155	239	0,2464616
16,290	548,7	548,7	98,22	96,36	0,158	0,155	240	0,2458421
16,193	548,7	548,7	98,64	97,28	0,158	0,155	241	0,2443931
16,262	548,7	548,6	98,41	96,58	0,158	0,155	242	0,2454294
16,267	548,7	548,7	98,48	96,61	0,158	0,155	243	0,2454294
16,238	548,7	548,7	98,49	96,69	0,158	0,155	244	0,2450148

	Outlet	Outlet	Average	Average	#1	#2		
Tunnel	Temp.	Temp.	99,47	98,24	System 1	System 2		SQRT
Velocity	Meter 1	Meter 2	Proportional Rates		Vol.Std.	Vol.Std.		Delta-P
			PR1	PR2			Time	
Ft/Sec	Deg. R	Deg. R	%	%	(ft3)	(ft3)	min	(in H2O)2
17,057	544,5	544,1			0,161	0,158	0	0,2551612
16,744	544,5	544,1	100,25	99,08	0,161	0,158	1	0,2518325
17,071	544,5	544,2	98,58	97,23	0,161	0,158	2	0,2565509
16,913	544,5	544,2	99,74	98,22	0,161	0,157	3	0,2537656
16,899	544,5	544,2	99,91	98,71	0,161	0,158	4	0,2533641
16,806	544,5	544,2	100,67	99,35	0,161	0,158	5	0,2517559
16,984	544,6	544,3	99,71	98,63	0,160	0,158	6	0,2541649
16,992	544,6	544,3	100,03	98,74	0,161	0,158	7	0,2541648
17,118	544,6	544,3	99,26	98,32	0,161	0,158	8	0,2557584
17,090	544,7	544,4	99,50	98,29	0,160	0,158	9	0,2551626
16,928	544,7	544,5	100,68	99,23	0,161	0,158	10	0,2527634
16,951	544,7	544,5	100,61	99,25	0,161	0,157	11	0,2527633
17,014	544,8	544,5	100,26	99,00	0,160	0,157	12	0,2537653
16,930	544,8	544,6	100,73	99,60	0,160	0,158	13	0,2523608
16,963	544,9	544,6	100,91	99,43	0,160	0,158	14	0,2527636
16,945	544,9	544,7	100,93	99,60	0,161	0,157	15	0,2523607
16,925	545,1	544,8	101,29	100,14	0,160	0,158	16	0,2517567
16,884	545,1	544,9	101,22	100,02	0,160	0,158	17	0,2513532
16,958	545,3	545,0	101,01	99,96	0,160	0,158	18	0,2523606
17,148	545,3	545,1	99,80	98,49	0,160	0,158	19	0,2551627
16,994	545,4	545,2	100,99	99,75	0,160	0,158	20	0,2527639
16,923	545,4	545,2	101,21	99,75	0,160	0,157	21	0,251757
17,037	545,5	545,3	100,52	99,15	0,160	0,157	22	0,2533655
17,186	545,5	545,3	99,46	98,39	0,160	0,157	23	0,2557591
17,086	545,5	545,3	100,18	98,97	0,160	0,157	24	0,2541661
16,894	545,5	545,4	101,23	99,85	0,160	0,157	25	0,2513548
17,284	545,6	545,4	99,02	97,75	0,160	0,157	26	0,2571459
17,232	545,7	545,5	99,20	97,99	0,160	0,157	27	0,2565524
17,330	545,7	545,5	98,58	97,15	0,160	0,157	28	0,2581313
17,323	545,7	545,6	98,60	97,37	0,160	0,157	29	0,2581307
17,076	545,7	545,5	100,20	98,77	0,160	0,157	30	0,2541664
17,191	545,7	545,6	99,24	98,18	0,160	0,157	31	0,2559896
17,078	545,7	545,6	100,22	99,02	0,160	0,157	32	0,2541667
17,014	545,8	545,6	100,31	99,26	0,160	0,158	33	0,253366
16,977	545,8	545,6	100,49	99,62	0,160	0,158	34	0,2527647
17,223	545,8	545,6	99,24	97,76	0,160	0,157	35	0,256552
17,143	545,8	545,6	99,58	98,42	0,160	0,157	36	0,2551633
17,187	545,8	545,6	99,54	98,21	0,160	0,157	37	0,2557591
17,137	545,8	545,7	99,58	98,37	0,160	0,157	38	0,2551634
17,277	545,8	545,7	98,53	97,57	0,160	0,157	39	0,2573361
17,220	545,9	545,7	99,10	97,74	0,160	0,157	40	0,2565521
17,168	545,8	545,7	99,31	98,37	0,160	0,157	41	0,2557589
17,178	545,8	545,7	99,38	98,13	0,160	0,157	42	0,2557591
17,226	545,8	545,7	98,91	97,82	0,160	0,157	43	0,2565524
17,139	545,8	545,7	99,58	98,32	0,160	0,157	44	0,2551632
17,191	545,8	545,7	99,08	97,87	0,160	0,157	45	0,2561564
17,173	545,9	545,7	99,22	97,93	0,160	0,157	46	0,2557585
17,180	545,8	545,7	99,32	98,02	0,160	0,157	47	0,2557596
17,011	545,8	545,7	100,25	99,24	0,160	0,157	48	0,2533656
17,062	545,8	545,7	99,99	98,64	0,160	0,157	49	0,2541655
17,264	545,9	545,8	98,68	97,94	0,160	0,157	50	0,2571452
17,167	545,9	545,8	99,28	98,28	0,160	0,158	51	0,2557596
17,253	545,9	545,8	98,66	97,31	0,160	0,157	52	0,2571453
17,157	545,9	545,8	99,34	98,01	0,160	0,157	53	0,2557593
17,107	545,8	545,8	99,25	98,13	0,160	0,157	54	0,2551633
17,192	545,8	545,7	98,69	97,78	0,160	0,157	55	0,2565518

16,998	545,8	545,7	99,81	98,67	0,160	0,157	56	0,2537672
17,257	545,8	545,7	98,33	97,38	0,160	0,157	57	0,2575409
17,239	545,8	545,7	98,43	97,09	0,160	0,157	58	0,2575402
17,326	545,8	545,7	97,74	96,53	0,160	0,157	59	0,2589164
17,221	545,8	545,6	98,32	96,84	0,160	0,157	60	0,25754
17,260	545,7	545,6	98,05	96,79	0,160	0,157	61	0,2581303
17,224	545,7	545,6	98,23	96,96	0,160	0,157	62	0,2575405
17,184	545,7	545,6	98,35	97,18	0,160	0,157	63	0,2571453
17,268	545,7	545,6	97,85	96,49	0,160	0,157	64	0,2585245
17,281	545,7	545,6	97,59	96,47	0,160	0,157	65	0,2589158
17,161	545,7	545,6	98,31	97,04	0,160	0,157	66	0,2571451
17,227	545,7	545,6	97,66	96,63	0,160	0,157	67	0,2581303
17,223	545,7	545,6	97,93	96,50	0,160	0,157	68	0,2581307
17,141	545,8	545,6	97,97	96,88	0,160	0,157	69	0,2571453
17,135	545,8	545,7	98,02	96,62	0,160	0,157	70	0,2571458
17,145	545,8	545,6	98,05	96,82	0,160	0,157	71	0,2571449
17,157	545,8	545,6	97,79	96,72	0,160	0,157	72	0,2575407
17,093	545,8	545,6	98,09	96,98	0,160	0,157	73	0,2565521
17,129	545,8	545,6	98,09	96,75	0,160	0,157	74	0,2571455
17,131	545,9	545,7	97,96	96,75	0,160	0,157	75	0,2571454
17,165	545,9	545,7	97,98	96,59	0,160	0,157	76	0,2575406
17,126	545,9	545,8	98,03	96,63	0,160	0,157	77	0,2571454
17,130	545,9	545,8	97,91	96,70	0,160	0,157	78	0,2571453
17,244	545,9	545,8	97,26	95,93	0,160	0,157	79	0,2589166
17,197	546,0	545,8	97,61	96,53	0,160	0,157	80	0,2581311
17,159	545,9	545,8	97,77	96,35	0,160	0,157	81	0,2575398
17,233	545,9	545,8	97,15	96,07	0,160	0,157	82	0,2589163
17,177	545,8	545,7	97,27	96,36	0,160	0,157	83	0,2581388
17,329	545,8	545,7	96,52	95,33	0,160	0,157	84	0,2604809
17,343	545,8	545,7	96,34	95,13	0,160	0,157	85	0,2608709
17,190	545,8	545,7	97,21	95,78	0,160	0,157	86	0,2585244
17,237	545,8	545,7	96,70	95,46	0,160	0,157	87	0,2595041
17,150	545,8	545,7	97,17	95,95	0,160	0,157	88	0,2581309
17,074	545,8	545,7	97,56	96,41	0,160	0,157	89	0,257146
17,132	545,8	545,6	97,08	95,94	0,160	0,157	90	0,2581313
16,994	545,7	545,6	98,00	96,72	0,160	0,157	91	0,2561566
17,012	545,7	545,6	97,68	96,34	0,160	0,157	92	0,2565527
16,923	545,6	545,5	98,20	96,91	0,160	0,157	93	0,2551638
16,772	545,6	545,5	99,32	98,14	0,160	0,157	94	0,252765
17,050	545,6	545,5	97,47	96,28	0,160	0,157	95	0,2571453
17,035	545,6	545,5	97,41	96,27	0,160	0,157	96	0,2571454
17,111	545,6	545,4	97,05	95,79	0,160	0,157	97	0,2581309
16,831	545,5	545,4	98,45	97,46	0,160	0,157	98	0,2541667
17,026	545,5	545,4	97,34	95,88	0,160	0,157	99	0,2571458
16,991	545,5	545,4	97,48	96,33	0,160	0,157	100	0,2565523
16,991	545,5	545,4	97,58	96,45	0,160	0,157	101	0,2565528
16,740	545,5	545,4	99,02	97,73	0,160	0,157	102	0,2527644
16,905	545,5	545,4	98,08	96,88	0,160	0,157	103	0,255164
16,934	545,4	545,4	97,71	96,59	0,160	0,157	104	0,2557593
16,778	545,3	545,3	98,74	97,44	0,160	0,157	105	0,2533655
16,894	545,3	545,3	98,21	97,05	0,160	0,157	106	0,2551638
16,664	545,3	545,3	99,50	98,15	0,160	0,157	107	0,2517575
16,731	545,3	545,3	99,03	97,75	0,160	0,157	108	0,2527647
16,800	545,4	545,3	98,57	97,38	0,160	0,157	109	0,2537664
16,513	545,4	545,3	100,46	99,20	0,160	0,157	110	0,2493263
16,553	545,4	545,4	100,10	99,06	0,160	0,157	111	0,2499362
16,589	545,5	545,4	99,99	99,09	0,160	0,157	112	0,2503424
16,620	545,5	545,4	99,72	98,57	0,160	0,157	113	0,25095
16,512	545,5	545,5	100,29	99,22	0,160	0,157	114	0,2493255
16,459	545,6	545,5	100,67	99,32	0,160	0,157	115	0,2485103
16,396	545,6	545,5	101,16	99,92	0,160	0,157	116	0,2474869

16,559	545,6	545,5	100,28	98,89	0,160	0,157	117	0,2499365
16,557	545,7	545,6	100,27	98,76	0,160	0,157	118	0,2499361
16,464	545,7	545,6	100,74	99,59	0,160	0,157	119	0,2485106
16,465	545,7	545,6	100,98	99,32	0,160	0,157	120	0,24851
16,582	545,7	545,6	100,01	98,50	0,160	0,157	121	0,250343
16,587	545,7	545,7	99,99	98,73	0,160	0,157	122	0,2503423
16,287	545,8	545,7	101,92	100,65	0,160	0,157	123	0,2458404
16,459	545,8	545,8	100,63	99,45	0,160	0,157	124	0,2485103
16,355	545,8	545,8	101,42	100,18	0,160	0,157	125	0,246871
16,354	545,9	545,8	101,32	100,18	0,160	0,157	126	0,246871
16,354	545,9	545,9	101,33	100,00	0,160	0,157	127	0,2468706
16,516	545,9	545,9	100,38	98,92	0,160	0,157	128	0,2493263
16,356	545,9	545,9	101,33	100,13	0,160	0,157	129	0,2468709
16,425	546,0	545,9	101,06	99,76	0,160	0,157	130	0,2478972
16,360	546,0	546,0	101,36	100,28	0,160	0,157	131	0,2468709
16,403	546,0	546,0	101,03	99,84	0,160	0,157	132	0,247487
16,406	546,1	546,1	101,17	99,65	0,160	0,157	133	0,2474869
16,339	546,2	546,1	101,41	100,21	0,160	0,157	134	0,2464607
16,475	546,2	546,2	100,61	99,53	0,159	0,157	135	0,2485106
16,433	546,3	546,3	100,92	99,64	0,160	0,157	136	0,2478978
16,366	546,3	546,3	101,33	100,21	0,160	0,157	137	0,2468712
16,366	546,3	546,3	101,35	99,96	0,160	0,157	138	0,2468711
16,435	546,4	546,3	100,98	99,79	0,160	0,157	139	0,247898
16,273	546,4	546,4	101,76	100,75	0,159	0,157	140	0,2454286
16,411	546,4	546,4	100,99	99,81	0,159	0,157	141	0,2474876
16,481	546,5	546,5	100,70	99,44	0,159	0,157	142	0,2485114
16,475	546,5	546,5	100,65	99,42	0,160	0,157	143	0,2485114
16,404	546,5	546,5	101,14	99,88	0,160	0,157	144	0,2474507
16,437	546,6	546,6	100,96	99,62	0,160	0,157	145	0,2478984
16,411	546,6	546,6	101,03	99,87	0,160	0,157	146	0,2474875
16,481	546,7	546,7	100,63	99,51	0,159	0,157	147	0,2485112
16,341	546,8	546,7	101,62	100,18	0,160	0,157	148	0,2464021
16,481	546,8	546,8	100,79	99,46	0,160	0,157	149	0,2485115
16,442	546,8	546,8	100,86	99,95	0,160	0,157	150	0,2478987
16,373	546,8	546,9	101,27	100,12	0,159	0,157	151	0,2468538
16,283	546,9	546,9	101,96	100,34	0,160	0,156	152	0,2455141
16,416	546,9	547,0	101,07	99,84	0,160	0,156	153	0,247488
16,414	547,0	547,0	101,01	99,86	0,159	0,157	154	0,2474881
16,350	547,0	547,1	101,36	100,32	0,159	0,157	155	0,2464615

	Outlet	Outlet	Average	Average	#1	#2		
Tunnel	Temp.	Temp.	101,35	100,57	System 1	System 2		SQRT
Velocity	Meter 1	Meter 2	Proportional Rates		Vol.Std.	Vol.Std.		Delta-P
			PR1	PR2			Time	
Ft/Sec	Deg. R	Deg. R	%	%	(ft3)	(ft3)	min	(in H2O)2
15,747	545,8	545,2			0,160	0,157	0	0,2357218
15,720	545,8	545,2	104,04	103,20	0,159	0,157	1	0,236796
15,634	545,7	545,2	104,82	104,03	0,159	0,157	2	0,2352916
15,688	545,7	545,3	104,79	104,22	0,159	0,157	3	0,2357225
15,610	545,7	545,3	105,56	104,94	0,159	0,157	4	0,2342101
15,596	545,7	545,3	104,20	103,32	0,159	0,157	5	0,2357219
15,584	545,7	545,4	103,99	103,34	0,159	0,157	6	0,2357267
15,706	545,7	545,4	102,95	102,39	0,159	0,157	7	0,2378657
15,660	545,7	545,4	102,93	102,38	0,159	0,157	8	0,2374382
15,662	545,7	545,4	103,07	102,28	0,159	0,157	9	0,2374382
15,651	545,7	545,4	103,04	102,33	0,159	0,157	10	0,2374382
15,605	545,7	545,4	103,11	102,38	0,159	0,157	11	0,2367962
15,699	545,7	545,4	102,48	101,68	0,159	0,156	12	0,238291
15,601	545,7	545,5	103,05	102,34	0,159	0,156	13	0,2367926
15,689	545,7	545,5	102,83	102,02	0,159	0,156	14	0,2378654
15,655	545,7	545,5	102,94	102,19	0,159	0,156	15	0,2374379
15,479	545,7	545,5	104,06	103,07	0,159	0,156	16	0,2348593
15,512	545,7	545,5	103,82	103,03	0,159	0,156	17	0,2352916
15,652	545,7	545,5	102,98	102,71	0,159	0,157	18	0,2374381
15,638	545,7	545,5	102,91	102,30	0,159	0,157	19	0,2374379
15,670	545,7	545,5	102,80	102,14	0,159	0,157	20	0,2378656
15,509	545,7	545,5	103,96	103,48	0,159	0,157	21	0,2352912
15,669	545,7	545,5	102,88	102,02	0,159	0,157	22	0,2378653
15,649	545,7	545,5	102,96	102,04	0,159	0,156	23	0,2374381
15,669	545,7	545,5	102,94	102,16	0,159	0,157	24	0,2378653
15,605	545,7	545,5	103,21	102,46	0,159	0,157	25	0,2367955
15,672	545,7	545,5	102,78	102,08	0,159	0,157	26	0,2378654
15,596	545,7	545,5	103,16	102,59	0,159	0,157	27	0,2367957
15,484	545,6	545,5	104,19	103,42	0,159	0,157	28	0,2348588
15,754	545,7	545,5	102,48	101,30	0,159	0,156	29	0,2389293
15,536	545,7	545,5	103,84	103,08	0,160	0,156	30	0,2357213
15,482	545,6	545,5	104,01	103,36	0,159	0,157	31	0,2348585
15,656	545,6	545,5	103,01	102,10	0,159	0,156	32	0,2374376
15,679	545,6	545,5	102,84	101,96	0,159	0,156	33	0,2378654
15,614	545,6	545,5	103,31	102,39	0,159	0,156	34	0,2367952
15,623	545,6	545,5	103,38	102,50	0,159	0,156	35	0,236795
15,631	545,6	545,5	103,44	102,74	0,159	0,157	36	0,2367952
15,635	545,6	545,5	103,40	102,66	0,159	0,157	37	0,2367953
15,778	545,6	545,5	102,50	101,87	0,159	0,157	38	0,238929
15,732	545,7	545,6	102,80	101,88	0,159	0,156	39	0,2382909
15,506	545,7	545,6	104,35	103,55	0,159	0,156	40	0,2348587
15,688	545,7	545,6	103,19	102,42	0,159	0,156	41	0,2374375
15,712	545,7	545,6	103,15	102,33	0,159	0,157	42	0,2378432
15,655	545,7	545,6	103,62	102,70	0,159	0,156	43	0,2367947
15,581	545,7	545,6	104,05	103,43	0,159	0,157	44	0,2357222
15,570	545,7	545,6	104,31	103,44	0,159	0,157	45	0,2352908
15,723	545,7	545,6	103,17	102,31	0,159	0,156	46	0,2378655
15,692	545,7	545,6	103,22	102,52	0,159	0,157	47	0,2374377
15,653	545,7	545,6	103,53	102,59	0,159	0,156	48	0,236796
15,550	545,7	545,6	104,16	103,42	0,159	0,156	49	0,2352916
15,648	545,7	545,6	103,57	102,55	0,159	0,156	50	0,2367955
15,653	545,7	545,6	103,59	102,69	0,159	0,156	51	0,2367955
15,545	545,7	545,6	104,19	103,38	0,159	0,156	52	0,2352908
15,799	545,7	545,6	102,75	101,95	0,159	0,157	53	0,2389293
15,746	545,7	545,6	103,15	102,50	0,160	0,157	54	0,2382194
15,580	545,7	545,6	104,01	103,02	0,160	0,157	55	0,2357213

15,683	545,6	545,6	103,16	102,47	0,159	0,156	56	0,237438
15,700	545,6	545,5	102,76	102,10	0,159	0,156	57	0,2378653
15,667	545,6	545,5	103,04	102,40	0,159	0,157	58	0,2374376
15,709	545,6	545,5	102,93	102,27	0,159	0,157	59	0,237865
15,629	545,6	545,5	103,43	102,66	0,159	0,157	60	0,2367953
15,709	545,6	545,6	103,09	102,21	0,159	0,157	61	0,2378653
15,566	545,6	545,6	103,89	103,15	0,159	0,156	62	0,2357212
15,676	545,6	545,6	103,23	102,70	0,159	0,157	63	0,2374374
15,624	545,6	545,6	103,49	102,76	0,160	0,157	64	0,2367952
15,725	545,6	545,6	102,69	101,99	0,159	0,157	65	0,2382908
15,662	545,6	545,6	103,05	102,50	0,159	0,157	66	0,2374379
15,523	545,6	545,6	103,96	103,30	0,159	0,157	67	0,2352912
15,540	545,6	545,6	104,08	103,13	0,159	0,156	68	0,2352912
15,701	545,6	545,6	102,95	102,34	0,159	0,156	69	0,2378657
15,523	545,7	545,7	104,42	103,61	0,159	0,157	70	0,234859
15,672	545,7	545,7	103,04	102,17	0,159	0,156	71	0,237438
15,728	545,7	545,7	102,60	101,98	0,159	0,156	72	0,2382916
15,727	545,8	545,7	102,78	102,14	0,159	0,157	73	0,2382918
15,740	545,8	545,8	102,75	101,96	0,159	0,157	74	0,2382917
15,674	545,8	545,8	103,13	102,06	0,159	0,156	75	0,2374383
15,676	545,9	545,8	103,08	102,30	0,159	0,156	76	0,2374383
15,728	545,9	545,8	102,64	101,97	0,159	0,156	77	0,2382917
15,708	545,9	545,8	102,84	102,27	0,159	0,157	78	0,2378658
15,708	545,9	545,8	102,84	102,08	0,159	0,156	79	0,2378658
15,734	545,9	545,8	103,07	102,35	0,159	0,156	80	0,2378657
15,510	545,9	545,8	104,27	103,48	0,159	0,156	81	0,23486
15,671	545,9	545,8	103,20	102,29	0,159	0,156	82	0,2373908
15,633	545,9	545,9	103,31	102,87	0,159	0,157	83	0,2367964
15,725	545,9	545,9	102,65	101,89	0,159	0,157	84	0,2382923
15,663	546,0	545,9	102,73	102,42	0,159	0,157	85	0,2374383
15,666	546,0	545,9	103,17	102,19	0,159	0,156	86	0,2374385
15,703	546,0	546,0	102,86	102,01	0,159	0,156	87	0,2378663
15,668	546,1	546,0	102,98	102,40	0,159	0,156	88	0,2374386
15,508	546,1	546,1	104,32	103,57	0,159	0,157	89	0,2348597
15,702	546,2	546,1	102,85	101,97	0,159	0,156	90	0,2378668
15,505	546,2	546,1	104,20	103,19	0,159	0,156	91	0,2348599
15,770	546,3	546,2	102,44	101,51	0,159	0,156	92	0,2389305
15,703	546,3	546,2	102,84	101,79	0,159	0,156	93	0,2378669
15,674	546,3	546,3	103,00	102,34	0,159	0,156	94	0,2374391
15,703	546,4	546,3	102,90	101,94	0,159	0,156	95	0,2378113
15,574	546,4	546,3	103,91	103,20	0,159	0,156	96	0,2357231
15,695	546,4	546,4	103,23	102,48	0,159	0,156	97	0,2374391
15,756	546,4	546,4	102,93	101,98	0,159	0,156	98	0,2382924
15,745	546,4	546,4	102,76	102,07	0,159	0,156	99	0,2382925
15,682	546,5	546,4	102,88	102,31	0,159	0,156	100	0,2374426
15,648	546,5	546,5	103,29	102,69	0,159	0,156	101	0,236798
15,706	546,5	546,5	102,73	102,30	0,159	0,157	102	0,2378673
15,537	546,6	546,5	104,16	103,12	0,159	0,156	103	0,2352929
15,764	546,6	546,5	102,96	102,06	0,159	0,156	104	0,2382929
15,574	546,6	546,6	103,76	103,23	0,159	0,156	105	0,2357236
15,710	546,6	546,6	102,77	102,30	0,159	0,157	106	0,2378672
15,684	546,7	546,6	103,03	102,30	0,159	0,156	107	0,2374398
15,639	546,7	546,7	103,35	102,59	0,159	0,156	108	0,2367976
15,713	546,7	546,7	102,78	102,21	0,159	0,156	109	0,2378676
15,743	546,8	546,7	102,61	101,72	0,159	0,156	110	0,2382935
15,631	546,8	546,8	103,20	102,45	0,159	0,156	111	0,2367616
15,682	546,8	546,8	103,12	102,37	0,159	0,156	112	0,2374397
15,632	546,9	546,8	103,27	102,47	0,159	0,156	113	0,2367975
15,676	546,9	546,8	102,91	102,11	0,159	0,156	114	0,2374398
15,775	547,0	546,9	102,37	101,62	0,159	0,156	115	0,2389314
15,476	547,0	546,9	104,41	103,65	0,159	0,156	116	0,2342116

15,679	547,0	546,9	102,88	102,32	0,159	0,156	117	0,2374396
15,629	547,0	547,0	103,27	102,58	0,159	0,156	118	0,2367975
15,645	547,0	547,0	103,22	102,68	0,159	0,156	119	0,2367976
15,694	547,0	547,0	103,19	102,09	0,159	0,156	120	0,2374397
15,688	547,1	547,0	103,08	102,34	0,159	0,156	121	0,23744
15,723	547,1	547,0	102,75	102,10	0,159	0,156	122	0,2379714
15,572	547,1	547,0	103,78	102,87	0,159	0,156	123	0,2357242
15,687	547,1	547,1	103,00	102,36	0,159	0,156	124	0,2374402
15,687	547,2	547,1	102,92	102,28	0,159	0,156	125	0,2374379
15,738	547,2	547,1	102,70	101,92	0,159	0,156	126	0,2382934
15,735	547,2	547,1	102,67	101,78	0,159	0,156	127	0,2382933
15,801	547,2	547,1	102,16	101,31	0,159	0,156	128	0,2393565
15,736	547,3	547,2	102,63	102,15	0,159	0,156	129	0,2382939
15,724	547,3	547,2	102,41	101,71	0,159	0,156	130	0,2382936
15,686	547,3	547,2	103,02	102,22	0,159	0,156	131	0,2374404
15,731	547,3	547,2	102,49	101,51	0,159	0,156	132	0,2382938
15,636	547,3	547,3	103,14	102,55	0,159	0,156	133	0,2367986
15,566	547,3	547,3	103,77	102,69	0,159	0,156	134	0,2357244
15,668	547,3	547,3	102,78	101,91	0,159	0,156	135	0,2374404
15,732	547,3	547,3	102,47	101,88	0,159	0,156	136	0,2382937
15,726	547,4	547,3	102,51	101,72	0,159	0,156	137	0,2382942
15,690	547,4	547,3	102,66	101,65	0,159	0,156	138	0,2378683
15,654	547,4	547,3	102,72	101,99	0,159	0,156	139	0,2374403
15,675	547,4	547,3	103,03	102,13	0,159	0,156	140	0,2374407
15,694	547,4	547,3	102,75	101,93	0,159	0,156	141	0,2378679
15,687	547,4	547,3	102,68	102,17	0,159	0,156	142	0,2378688
15,652	547,4	547,3	102,62	102,08	0,159	0,156	143	0,2374404
15,528	547,4	547,3	103,83	103,20	0,159	0,156	144	0,2352948
15,654	547,4	547,3	102,89	101,90	0,159	0,156	145	0,2374404
15,547	547,4	547,4	103,53	102,74	0,159	0,156	146	0,2357244
15,652	547,4	547,4	102,72	102,07	0,159	0,156	147	0,2374406
15,610	547,4	547,4	103,04	102,30	0,159	0,156	148	0,2367984
15,555	547,4	547,4	103,50	102,62	0,159	0,156	149	0,2357248
15,686	547,4	547,4	102,49	101,75	0,159	0,156	150	0,2378687
15,609	547,5	547,4	102,88	102,11	0,159	0,156	151	0,2367984
15,541	547,5	547,4	103,47	102,42	0,159	0,156	152	0,2357249
15,659	547,5	547,4	102,71	102,04	0,159	0,156	153	0,2374409
15,680	547,5	547,5	102,61	101,85	0,159	0,156	154	0,2378683
15,604	547,4	547,4	102,94	102,22	0,159	0,156	155	0,2367988
15,478	547,4	547,4	103,76	103,11	0,159	0,156	156	0,2348619
15,676	547,4	547,4	102,33	101,46	0,159	0,156	157	0,2378691
15,679	547,4	547,4	102,58	101,71	0,159	0,156	158	0,2378689
15,609	547,3	547,4	102,99	101,85	0,159	0,156	159	0,2367991
15,525	547,3	547,3	103,39	102,57	0,159	0,156	160	0,2357249
15,690	547,2	547,3	102,13	101,55	0,159	0,156	161	0,2382938
15,630	547,2	547,3	102,54	102,07	0,159	0,156	162	0,2374411
15,686	547,1	547,3	102,23	101,48	0,159	0,156	163	0,2382944
15,589	547,1	547,2	102,91	101,92	0,159	0,156	164	0,2367988
15,589	547,1	547,2	102,89	102,10	0,159	0,156	165	0,2367988
15,588	547,2	547,2	102,89	102,08	0,159	0,156	166	0,2367988
15,688	547,2	547,3	102,27	101,45	0,159	0,156	167	0,2382947
15,417	547,2	547,3	104,09	103,20	0,159	0,156	168	0,2342128
15,588	547,1	547,2	102,94	102,14	0,159	0,156	169	0,2367991
15,690	547,1	547,2	102,14	101,43	0,159	0,156	170	0,2382942
15,655	547,1	547,2	102,45	101,80	0,159	0,156	171	0,2378686
15,627	547,1	547,2	102,62	101,98	0,159	0,156	172	0,2374403
15,486	547,1	547,2	103,64	102,73	0,159	0,156	173	0,2352941
15,674	547,1	547,2	102,47	101,92	0,159	0,156	174	0,2378679
15,635	547,1	547,2	102,54	101,79	0,159	0,156	175	0,2374407
15,661	547,2	547,2	102,35	101,56	0,159	0,156	176	0,2378681
15,521	547,2	547,2	103,44	102,34	0,159	0,156	177	0,2357245

15,586	547,2	547,2	102,75	101,87	0,159	0,156	178	0,2367985
15,644	547,2	547,2	102,59	101,89	0,159	0,156	179	0,2374408
15,684	547,2	547,3	102,21	101,36	0,159	0,156	180	0,2382936
15,591	547,2	547,3	102,91	102,26	0,159	0,156	181	0,2367982
15,682	547,2	547,3	102,11	101,26	0,159	0,156	182	0,2382936
15,462	547,3	547,3	103,67	102,96	0,159	0,156	183	0,2348611
15,659	547,3	547,3	102,45	101,52	0,159	0,156	184	0,2378681
15,686	547,3	547,3	102,15	101,19	0,159	0,156	185	0,2382931
15,664	547,3	547,4	102,36	101,60	0,159	0,156	186	0,2378683
15,590	547,4	547,4	102,81	102,27	0,159	0,156	187	0,2368015
16,186	547,4	547,4	98,87	98,17	0,159	0,156	188	0,2458431
16,131	547,4	547,4	99,28	98,39	0,159	0,156	189	0,2450157
16,062	547,4	547,5	99,60	98,87	0,159	0,156	190	0,243978
16,184	547,4	547,5	98,87	98,27	0,159	0,156	191	0,2458425
16,085	547,4	547,5	99,49	98,51	0,159	0,156	192	0,2443937
16,133	547,4	547,5	99,25	98,36	0,159	0,156	193	0,2450155
16,084	547,4	547,5	99,39	98,69	0,159	0,156	194	0,2443939
16,220	547,3	547,4	98,70	97,91	0,159	0,156	195	0,2464622
16,179	547,4	547,4	98,92	98,07	0,159	0,156	196	0,2458427
16,178	547,3	547,4	98,82	98,17	0,159	0,156	197	0,2458429
16,059	547,3	547,4	99,70	99,34	0,159	0,156	198	0,243978
16,075	547,2	547,3	99,47	98,79	0,159	0,156	199	0,2443943
16,036	547,2	547,3	100,13	99,39	0,159	0,156	200	0,243353
15,925	547,2	547,3	100,43	99,94	0,159	0,156	201	0,2418879
16,073	547,3	547,4	99,71	98,95	0,159	0,156	202	0,2439779
16,130	547,3	547,4	99,34	98,40	0,159	0,156	203	0,2450158
16,163	547,3	547,4	99,20	98,31	0,159	0,156	204	0,2454302
16,017	547,3	547,4	99,85	99,15	0,159	0,156	205	0,243353
16,100	547,3	547,4	99,51	98,83	0,159	0,156	206	0,2443933
16,133	547,4	547,4	99,34	98,51	0,159	0,156	207	0,2450156
16,141	547,4	547,4	99,16	98,78	0,159	0,156	208	0,2450159
15,900	547,4	547,4	100,54	100,07	0,158	0,156	209	0,2414686
15,893	547,4	547,4	100,74	100,08	0,159	0,156	210	0,2414685
16,156	547,4	547,5	99,04	98,29	0,159	0,156	211	0,2454303
16,061	547,4	547,5	99,74	99,07	0,159	0,156	212	0,243978
16,084	547,5	547,5	99,32	98,69	0,159	0,156	213	0,2443937
16,012	547,5	547,5	99,92	99,17	0,159	0,156	214	0,2433529
16,047	547,5	547,5	99,52	98,66	0,159	0,156	215	0,2439784
16,020	547,4	547,5	99,84	99,15	0,159	0,156	216	0,2433533
16,081	547,4	547,5	99,55	98,66	0,159	0,156	217	0,2443935
16,160	547,4	547,4	98,89	97,91	0,159	0,156	218	0,2455329
16,017	547,4	547,5	99,83	99,38	0,159	0,156	219	0,2433537
16,076	547,5	547,5	99,40	98,66	0,159	0,156	220	0,2443677
16,079	547,4	547,5	99,47	98,58	0,159	0,156	221	0,2443938
16,144	547,4	547,5	99,11	98,19	0,159	0,156	222	0,2454301
16,074	547,4	547,5	99,45	98,62	0,159	0,156	223	0,2443939
16,097	547,5	547,5	99,65	98,57	0,159	0,156	224	0,2443939
16,124	547,4	547,5	99,18	98,52	0,159	0,156	225	0,2450163
16,142	547,5	547,5	99,01	98,28	0,159	0,156	226	0,2454304
16,125	547,4	547,5	99,00	98,34	0,159	0,156	227	0,2450865
16,050	547,4	547,5	99,64	98,86	0,159	0,156	228	0,2439782
16,081	547,4	547,5	99,53	98,71	0,159	0,156	229	0,2443939
16,149	547,5	547,5	99,04	98,23	0,159	0,156	230	0,2454315
16,054	547,5	547,5	99,54	98,98	0,159	0,156	231	0,2439789
16,058	547,5	547,5	99,58	98,94	0,159	0,156	232	0,2439787
16,062	547,5	547,5	99,49	98,87	0,159	0,156	233	0,244081
15,920	547,5	547,6	100,49	99,78	0,159	0,156	234	0,2418897
16,117	547,5	547,6	99,13	98,47	0,159	0,156	235	0,2450161
15,890	547,5	547,5	100,57	100,18	0,159	0,156	236	0,24147
16,051	547,5	547,5	99,57	98,56	0,159	0,156	237	0,2439787
16,221	547,5	547,6	98,63	97,66	0,159	0,155	238	0,2464629

16,048	547,5	547,6	99,62	98,71	0,159	0,156	239	0,2439789
16,148	547,5	547,5	99,05	98,19	0,159	0,156	240	0,2454309
16,001	547,4	547,5	99,64	98,96	0,159	0,156	241	0,2433533
16,114	547,4	547,5	99,10	98,63	0,158	0,156	242	0,2450156
16,139	547,4	547,5	99,14	98,31	0,159	0,156	243	0,2454304
16,133	547,4	547,5	98,99	98,07	0,159	0,156	244	0,2454306
16,132	547,4	547,5	98,96	98,07	0,159	0,156	245	0,2454307
16,131	547,3	547,4	98,99	98,15	0,159	0,156	246	0,2453681
15,895	547,3	547,4	100,39	99,64	0,159	0,156	247	0,2418892
16,128	547,2	547,3	98,93	98,39	0,159	0,156	248	0,2454309
16,112	547,2	547,3	99,11	98,33	0,159	0,156	249	0,2450162
15,992	547,2	547,3	99,75	99,24	0,159	0,156	250	0,2433534
16,040	547,2	547,3	99,61	98,78	0,159	0,156	251	0,2439786
16,117	547,2	547,3	99,22	98,32	0,159	0,156	252	0,2450163
16,074	547,2	547,3	99,38	98,55	0,159	0,156	253	0,2443944
16,146	547,2	547,3	99,00	98,31	0,159	0,156	254	0,2454305
16,114	547,2	547,3	99,16	98,18	0,159	0,156	255	0,2450165
15,846	547,2	547,3	101,02	100,11	0,159	0,156	256	0,2408371
16,181	547,2	547,3	98,89	98,36	0,159	0,156	257	0,2458432
16,122	547,3	547,3	99,36	98,36	0,159	0,156	258	0,2450158
16,088	547,3	547,3	99,50	98,73	0,159	0,156	259	0,2443936
16,087	547,3	547,3	99,61	98,92	0,159	0,156	260	0,2443934
16,014	547,3	547,4	99,84	99,71	0,159	0,156	261	0,2433529
16,049	547,3	547,4	99,49	98,71	0,159	0,156	262	0,2439784
16,170	547,3	547,4	98,84	98,05	0,159	0,156	263	0,2458432
15,890	547,3	547,4	100,71	99,83	0,159	0,156	264	0,2414687
16,148	547,3	547,4	99,03	98,18	0,159	0,156	265	0,2454305
16,120	547,3	547,4	99,18	98,54	0,159	0,156	266	0,2450153
15,925	547,3	547,4	100,70	99,80	0,159	0,156	267	0,2418886
16,013	547,3	547,4	100,10	99,36	0,159	0,156	268	0,2433533
16,084	547,4	547,4	99,60	98,62	0,159	0,156	269	0,244394
16,054	547,4	547,5	99,60	98,99	0,159	0,156	270	0,2439786
15,912	547,4	547,5	100,46	99,82	0,159	0,156	271	0,2418885
16,124	547,4	547,5	99,22	98,55	0,159	0,156	272	0,2450159
16,147	547,4	547,5	99,05	98,26	0,159	0,156	273	0,2454305
16,057	547,4	547,5	99,71	99,00	0,159	0,156	274	0,2439783
16,079	547,4	547,5	99,34	98,78	0,159	0,156	275	0,2443936
16,092	547,4	547,5	99,51	98,79	0,159	0,156	276	0,2443935
16,030	547,4	547,5	99,79	99,36	0,159	0,156	277	0,2434589
16,151	547,4	547,5	98,96	98,24	0,159	0,156	278	0,2454309
16,177	547,4	547,5	99,01	97,75	0,159	0,155	279	0,2458435
16,084	547,4	547,5	99,51	98,84	0,159	0,156	280	0,2443952
16,171	547,4	547,5	98,76	98,15	0,159	0,156	281	0,2458439
16,086	547,5	547,5	99,56	98,70	0,159	0,156	282	0,2443944
16,086	547,5	547,5	99,46	98,88	0,159	0,156	283	0,244394
16,019	547,5	547,6	100,00	99,47	0,159	0,156	284	0,2433536
16,153	547,5	547,6	99,10	98,37	0,159	0,156	285	0,2454312
16,031	547,5	547,6	99,95	99,13	0,159	0,156	286	0,2433534
16,060	547,5	547,6	99,58	98,85	0,159	0,156	287	0,2439781
16,080	547,5	547,6	99,26	98,66	0,158	0,156	288	0,244394
16,059	547,6	547,6	99,61	98,70	0,158	0,156	289	0,2439787
16,084	547,6	547,6	99,55	98,82	0,159	0,156	290	0,2443935
16,126	547,6	547,6	99,23	98,44	0,159	0,156	291	0,2450161
16,154	547,6	547,7	98,99	98,41	0,159	0,156	292	0,2454309
16,128	547,6	547,7	99,29	98,51	0,159	0,156	293	0,245016
16,056	547,6	547,7	99,52	99,07	0,159	0,156	294	0,2439787
16,153	547,7	547,7	99,03	98,22	0,159	0,156	295	0,2454324
16,056	547,7	547,7	99,74	98,97	0,159	0,156	296	0,2439785
16,067	547,7	547,7	99,87	98,93	0,159	0,156	297	0,2439792
16,125	547,7	547,8	99,16	98,22	0,159	0,156	298	0,2450163
16,086	547,8	547,8	99,34	98,58	0,158	0,156	299	0,2443942

16,096	547,8	547,8	99,55	98,73	0,159	0,156	300	0,2443308
16,186	547,8	547,8	98,86	97,89	0,159	0,156	301	0,2458441
16,061	547,8	547,8	99,48	98,74	0,158	0,155	302	0,2439789
16,023	547,8	547,8	99,78	99,02	0,158	0,156	303	0,2433535
16,038	547,8	547,8	99,72	98,94	0,158	0,156	304	0,2436285
16,197	547,8	547,8	98,91	98,19	0,159	0,156	305	0,245844
16,177	547,8	547,9	98,92	98,14	0,159	0,156	306	0,2458439
16,096	547,9	547,9	99,54	98,84	0,159	0,156	307	0,2443938
16,054	547,9	547,9	99,50	98,97	0,159	0,156	308	0,2439788
16,153	547,9	547,9	99,10	98,17	0,159	0,156	309	0,2454311
16,016	547,9	547,9	99,79	99,17	0,159	0,156	310	0,2433535
16,016	547,9	547,9	100,03	99,08	0,159	0,156	311	0,2433542
16,127	547,9	548,0	99,17	98,50	0,159	0,156	312	0,2450081
16,014	547,9	548,0	99,89	99,07	0,159	0,156	313	0,2433547
16,063	547,9	548,0	99,64	98,74	0,159	0,156	314	0,2439795
16,158	547,9	548,0	99,09	98,31	0,159	0,156	315	0,2454312
16,097	547,9	548,0	99,37	98,67	0,159	0,156	316	0,2444487
16,060	547,9	548,0	99,55	98,98	0,158	0,156	317	0,2439794
16,128	547,9	548,0	99,29	98,25	0,159	0,156	318	0,2450171
16,146	547,9	548,0	99,30	98,64	0,159	0,156	319	0,2450174
16,139	547,9	548,0	99,10	98,27	0,159	0,156	320	0,2451107
15,917	547,9	548,0	100,50	99,53	0,159	0,155	321	0,2418894
16,061	547,9	548,0	99,63	98,80	0,159	0,156	322	0,2439796
16,123	547,9	548,0	99,11	98,29	0,159	0,156	323	0,2450172
16,122	547,9	548,0	99,06	98,38	0,158	0,156	324	0,2450171
16,059	548,0	548,0	99,69	98,96	0,159	0,156	325	0,2439796
16,091	548,0	548,1	99,55	98,62	0,159	0,156	326	0,2443951
16,097	548,0	548,1	99,54	98,80	0,159	0,156	327	0,2443947
15,890	548,0	548,1	100,48	99,89	0,159	0,156	328	0,2414703
16,127	548,0	548,1	99,14	98,57	0,158	0,156	329	0,2450169
16,130	548,0	548,1	99,16	98,61	0,159	0,156	330	0,2450172
16,083	548,0	548,1	99,18	98,50	0,158	0,156	331	0,2443949
16,083	548,0	548,1	99,54	98,51	0,158	0,155	332	0,2443947
16,054	548,0	548,1	99,52	98,67	0,159	0,156	333	0,2439795
16,017	548,0	548,1	99,92	98,98	0,159	0,156	334	0,2433538
15,794	548,0	548,1	101,03	100,57	0,158	0,156	335	0,2399934
16,132	548,0	548,1	99,21	98,56	0,158	0,156	336	0,2450171
16,017	548,0	548,1	99,74	99,10	0,158	0,156	337	0,2433545
16,027	548,0	548,1	99,91	98,89	0,158	0,156	338	0,243354
16,130	548,0	548,1	99,12	98,48	0,159	0,156	339	0,2450168
16,020	548,0	548,1	99,79	98,89	0,158	0,156	340	0,2433546
16,157	548,0	548,1	99,12	98,22	0,159	0,156	341	0,245432
16,088	548,0	548,1	99,46	98,71	0,159	0,156	342	0,2443949
16,151	548,0	548,1	99,00	98,18	0,159	0,156	343	0,2454324
16,138	548,0	548,1	99,17	98,47	0,159	0,156	344	0,2450173
16,127	548,0	548,1	99,14	98,32	0,158	0,156	345	0,2450177
16,061	548,0	548,1	99,47	98,61	0,158	0,155	346	0,2439802
16,137	548,0	548,1	99,12	98,42	0,158	0,155	347	0,2450172
16,129	548,0	548,1	99,05	98,52	0,158	0,156	348	0,2450166
16,154	548,0	548,1	98,94	98,16	0,158	0,156	349	0,245432
16,094	548,0	548,1	99,36	98,61	0,158	0,156	350	0,244392
16,090	548,0	548,1	99,30	98,66	0,158	0,156	351	0,2443951
16,031	548,0	548,1	99,81	99,08	0,158	0,156	352	0,2433544
16,062	548,0	548,1	99,61	98,71	0,158	0,156	353	0,24398
16,068	548,0	548,1	99,64	98,77	0,159	0,156	354	0,2439773
16,159	548,0	548,1	98,91	98,24	0,158	0,156	355	0,2454322
15,926	548,0	548,1	100,42	99,71	0,158	0,156	356	0,2418899
16,135	548,0	548,1	99,21	98,30	0,159	0,156	357	0,245017
16,093	548,0	548,1	99,39	98,35	0,158	0,155	358	0,2443948
16,157	548,0	548,1	98,81	98,20	0,158	0,155	359	0,245432
15,898	548,0	548,1	100,64	99,84	0,158	0,156	360	0,2414699

16,075	548,0	548,1	99,69	98,96	0,159	0,156	361	0,2439797
16,068	548,0	548,1	99,60	98,68	0,159	0,156	362	0,2439797
16,094	548,0	548,1	99,37	98,59	0,158	0,155	363	0,2443953
16,060	548,0	548,1	99,55	98,76	0,158	0,156	364	0,2439796
16,068	548,0	548,1	99,71	99,04	0,159	0,156	365	0,2439802
16,064	548,0	548,1	99,57	98,96	0,159	0,156	366	0,2439792
16,132	548,0	548,1	99,09	98,26	0,158	0,156	367	0,2450169
16,084	548,0	548,1	99,45	98,64	0,159	0,156	368	0,2443944
16,061	548,0	548,1	99,64	98,58	0,159	0,155	369	0,2439796
16,086	548,0	548,1	99,45	-0,04	0,159	0,078	370	0,2443951
15,855	548,0	548,1	100,94	-0,11	0,159	0,000	371	0,2408391
15,399	548,0	548,1	104,05	-0,01	0,159	0,000	372	0,2337808
15,460	548,1	548,1	103,49	-0,06	0,159	0,000	373	0,2348633
15,394	548,0	548,1	104,01	-0,03	0,159	0,000	374	0,2337806
15,467	548,1	548,1	103,53	-0,01	0,159	0,000	375	0,2348629
15,386	548,1	548,1	103,95	-0,06	0,159	0,000	376	0,2337806

APPENDIX 3: Calibration data

APPENDIX 4: Unit pre burn



Wood Stove Preconditioning

Model: MCR 8362

Date: 2018-07-18

Test Engineer: WENGEL

Total Hours: 54

All fuel is natural untreated wood, 15% to 25% moisture (wet)

Date	Time	ET (min)	Scale (lbs)	Flue Temp (°F)	Cat Temp (°F)
2018-07-16	2:30pm	0	16,5	242	677
		5	15,9	365	1128
		10	15,5	301	855
		15	15,0	302	902
		20	14,4	320	1012
		25	13,7	337	1030
		30	12,9	349	1012
		35	12,1	357	1017
		40	11,3	360	1021
		45	10,6	361	1021
		50	9,9	360	1038
		55	9,2	360	1049
		60	8,5	358	1033
		65	7,9	356	1047
		70	7,3	351	1049
		75	6,8	343	1012
		80	6,3	336	1026
		85	5,8	330	1023
90	5,5	323	994		
95	5,1	314	940		
100	4,8	308	981		
105	4,5	307	922		
110	4,1	305	914		
115	3,8	301	891		
120	3,6	290	852		
125	3,4	281	826		
130	3,2	271	812		
135	3,1	262	801		
140	3,0	256	781		
145	2,8	250	785		
150	2,7	249	804		
155	2,6	250	823		
160	2,5	250	811		
165	2,4	249	819		
170	2,3	248	811		
175	2,2	248	816		
180	2,1	248	812		



Wood Stove Preconditioning

Model: MCR 8362

Date: 2018-07-18

Test Engineer: WENGEL

Total Hours: 54

All fuel is natural untreated wood, 15% to 25% moisture (wet)

Date	Time	ET (min)	Scale (lbs)	Flue Temp (°F)	Cat Temp (°F)
		185	1,9	248	810
		190	1,8	247	796
		195	1,7	245	792
		200	1,6	243	792
		205	1,5	242	791
		210	1,4	241	788
		215	1,3	241	792
		220	1,2	240	799
		225	1,1	240	788
		230	1,0	239	757
		235	0,9	234	735
		240	0,8	230	729
		245	0,7	227	721
		250	0,6	226	724
		255	0,5	224	699
		260	0,4	222	682
		265	0,3	220	683
		270	0,3	218	697
		275	0,2	218	689
		280	0,1	218	694
		285	0,0	217	691
2018-07-17	1:33PM	1	16,5	183	608
		5	16,0	317	906
		10	15,9	239	644
		15	15,7	219	637
		20	15,5	212	675
		25	15,2	220	821
		30	14,9	228	813
		35	14,4	241	971
		40	14,1	250	982
		45	13,6	264	938
		50	13,1	272	1026
		55	12,6	280	1042
		60	12,2	283	1042
		65	11,7	284	955
		70	11,2	285	1034
		75	10,8	280	898



Wood Stove Preconditioning

Model: MCR 8362

Date: 2018-07-18

Test Engineer: WENGEL

Total Hours: 54

All fuel is natural untreated wood, 15% to 25% moisture (wet)

Date	Time	ET (min)	Scale (lbs)	Flue Temp (°F)	Cat Temp (°F)
		80	10,4	275	951
		85	10,0	275	931
		90	9,5	270	857
		95	9,2	265	854
		100	8,8	263	851
		105	8,3	263	853
		110	7,9	261	841
		115	7,5	260	826
		120	7,2	254	810
		125	6,9	249	793
		130	6,6	245	803
		135	6,2	242	804
		140	5,9	242	826
		145	5,6	243	866
		150	5,3	243	866
		155	4,9	242	846
		160	4,7	239	802
		165	4,4	233	786
		170	4,2	230	855
		175	4,1	225	814
		180	3,9	219	790
		185	3,8	212	755
		190	3,6	206	746
		195	3,5	202	756
		200	3,4	198	751
		205	3,3	195	765
		210	3,2	193	769
		215	3,1	192	759
		220	3,0	191	766
		225	2,9	190	764
		230	2,9	189	759
		235	2,8	188	757
		240	2,7	187	759
		245	2,6	187	767
		250	2,5	187	775
		255	2,4	187	785
		260	2,4	188	784



Wood Stove Preconditioning

Model: MCR 8362

Date: 2018-07-18

Test Engineer: WENGEL

Total Hours: 54

All fuel is natural untreated wood, 15% to 25% moisture (wet)

Date	Time	ET (min)	Scale (lbs)	Flue Temp (°F)	Cat Temp (°F)
		265	2,3	188	783
		270	2,2	186	731
		275	2,1	184	732
		280	2,0	183	743
		285	2,0	183	761
		290	1,9	183	767
		295	1,8	184	740
		300	1,7	181	718
		305	1,6	180	722
		310	1,6	179	730
		315	1,5	178	732
		320	1,3	178	734
		325	1,3	179	736
		330	1,3	179	735
		335	1,2	178	711
		340	1,1	179	764
		345	1,0	180	709
		350	0,9	177	701
		355	0,9	176	694
		360	0,8	174	704
		365	0,7	173	703
		370	0,7	173	703
		375	0,6	173	696
		380	0,5	172	699
		385	0,5	172	710
		390	0,4	173	713
		395	0,3	174	723
		400	0,3	175	716
		405	0,2	175	706
		410	0,1	174	692
		415	0,1	173	683
		420	0,0	172	680
2018-07-18	1:14PM	0	14,0	481	717
		5	12,9	581	849
		10	11,5	659	854
		15	10,0	606	1119
		20	9,0	534	1233



Wood Stove Preconditioning

Model: MCR 8362

Date: 2018-07-18

Test Engineer: WENGEL

Total Hours: 54

All fuel is natural untreated wood, 15% to 25% moisture (wet)

Date	Time	ET (min)	Scale (lbs)	Flue Temp (°F)	Cat Temp (°F)
		25	7,9	535	1250
		30	6,8	552	1289
		35	5,7	560	1283
		40	4,7	552	1301
		45	4,0	539	1201
		50	3,3	527	1152
		55	2,8	509	1068
		60	2,4	493	980
		65	2,0	476	914
		70	18,4	527	1269
		75	17,1	559	1283
		80	15,8	573	1282
		85	14,6	581	1286
		90	13,3	582	1295
		95	12,1	579	1298
		100	11,0	574	1318
		105	10,1	567	1329
		110	9,2	560	1321
		115	8,4	549	1311
		120	7,6	534	1256
		125	7,0	520	1179
		130	6,5	438	1095
		135	6,1	398	1043
		140	5,7	379	1058
		145	5,4	360	1014
		150	5,2	325	920
		155	5,0	304	861
		160	4,9	288	846
		165	4,8	276	854
		170	4,7	268	833
		175	4,6	262	820
		180	4,6	255	799
		185	4,5	250	787
		190	4,4	245	776
		195	4,3	242	782
		200	4,2	240	790
		205	4,1	239	788



Wood Stove Preconditioning

Model: MCR 8362

Date: 2018-07-18

Test Engineer: WENGEL

Total Hours: 54

All fuel is natural untreated wood, 15% to 25% moisture (wet)

Date	Time	ET (min)	Scale (lbs)	Flue Temp (°F)	Cat Temp (°F)
		210	4,0	239	801
		215	3,9	239	793
		220	3,8	238	793
		225	3,8	237	792
		230	3,7	236	785
		235	3,6	237	788
		240	3,5	237	796
		245	3,4	237	800
		250	3,3	237	794
		255	3,2	236	786
		260	4,1	274	780
		265	18,8	272	799
		270	18,5	269	884
		275	18,0	280	892
		280	17,5	292	948
		285	17,0	306	967
		290	16,2	325	946
		295	15,5	327	990
		300	14,8	336	964
		305	14,0	336	981
		310	13,3	336	988
		315	12,6	334	976
		320	12,0	333	1011
		325	11,4	332	1026
		330	10,8	332	1066
		335	10,3	332	1055
		340	9,7	330	1053
		345	9,2	328	1033
		350	8,8	322	977
		355	8,3	318	985
		360	7,9	313	962
		365	7,5	309	948
		370	7,1	300	891
		375	6,9	288	860
		380	6,6	278	828
		385	6,4	268	876
		390	6,3	260	829



Wood Stove Preconditioning

Model: MCR 8362

Date: 2018-07-18

Test Engineer: WENGEL

Total Hours: 54

All fuel is natural untreated wood, 15% to 25% moisture (wet)

Date	Time	ET (min)	Scale (lbs)	Flue Temp (°F)	Cat Temp (°F)
		395	6,2	254	819
		400	6,1	247	802
		405	5,9	242	775
		410	5,8	237	761
		415	5,7	232	751
		420	5,6	229	753
		425	5,5	227	752
		430	5,4	225	750
		435	5,2	224	747
		440	5,1	223	746
		445	5,0	222	748
		450	4,9	221	745
		455	4,8	220	748
		460	4,7	220	756
		465	4,6	221	768
		470	4,5	222	779
		475	4,4	225	782
		480	4,3	226	795
		485	4,2	227	800
		490	4,1	230	811
		495	4,0	230	808
		500	3,9	230	802
		505	3,8	230	800
		510	3,7	230	789
		515	3,6	228	780
		520	3,5	228	780
		525	3,5	227	780
		530	3,4	225	780
		535	3,3	225	790
		540	3,2	225	787
		545	3,1	224	788
		550	3,0	224	794
		555	2,9	223	783
		560	2,8	223	771
		565	2,8	222	776
		570	2,7	221	773
		575	2,6	220	777



Wood Stove Preconditioning

Model: MCR 8362

Date: 2018-07-18

Test Engineer: WENGEL

Total Hours: 54

All fuel is natural untreated wood, 15% to 25% moisture (wet)

Date	Time	ET (min)	Scale (lbs)	Flue Temp (°F)	Cat Temp (°F)
		580	2,5	221	783
		585	2,5	221	780
		590	2,4	221	785
		595	2,3	221	775
		600	2,2	220	773
		605	2,2	220	768
		610	2,1	219	784
		615	2,0	219	780
		620	2,0	219	780
		625	1,9	218	776
		630	1,8	218	791
		635	1,7	219	782
		640	1,7	217	766
		645	1,6	216	760
		650	1,6	215	741
		655	1,5	212	733
		660	1,5	211	729
		665	1,4	209	730
		670	1,3	206	715
		675	1,3	205	704
		680	1,2	203	702
		685	1,2	200	679
		690	1,1	200	681
		695	1,0	195	626
		700	1,0	192	625
		705	0,9	192	632
		710	0,9	191	637
		715	0,8	191	639
		720	0,8	191	657
		725	0,7	192	655
		730	0,7	191	626
		735	0,6	189	615
		740	0,6	187	612
		745	0,6	185	566
		750	0,5	182	555
		755	0,5	180	550
		760	0,5	178	568



Wood Stove Preconditioning

Model: MCR 8362

Date: 2018-07-18

Test Engineer: WENGEL

Total Hours: 54

All fuel is natural untreated wood, 15% to 25% moisture (wet)

Date	Time	ET (min)	Scale (lbs)	Flue Temp (°F)	Cat Temp (°F)
		765	0,4	177	550
		770	0,4	174	532
		775	0,4	172	525
		780	0,3	170	509
		785	0,3	167	500
		790	0,3	165	500
2018-07-19	10:27AM	0	19,9	386	755
		5	19,4	366	1013
		10	18,7	361	1123
		15	18,1	366	1110
		20	17,4	367	1090
		25	16,6	368	1075
		30	15,8	366	1047
		35	15,1	363	1039
		40	14,3	359	1041
		45	13,7	358	1188
		50	13,1	354	1139
		55	12,5	352	1130
		60	11,8	349	1107
		65	11,3	344	1076
		70	10,7	341	1071
		75	10,2	336	1062
		80	9,7	331	1063
		85	9,2	326	1037
		90	8,7	322	1012
		95	8,3	310	929
		100	7,9	300	917
		105	7,5	293	925
		110	7,2	288	914
		115	6,8	286	914
		120	6,5	279	880
		125	6,2	272	869
		130	5,9	263	841
		135	5,7	256	817
		140	5,6	250	828
		145	5,4	244	812
		150	5,3	239	813



Wood Stove Preconditioning

Model: MCR 8362

Date: 2018-07-18

Test Engineer: WENGEL

Total Hours: 54

All fuel is natural untreated wood, 15% to 25% moisture (wet)

Date	Time	ET (min)	Scale (lbs)	Flue Temp (°F)	Cat Temp (°F)
		155	5,2	236	836
		160	5,0	235	809
		165	4,9	231	800
		170	4,8	228	783
		175	4,7	224	787
		180	4,6	221	777
		185	4,5	218	777
		190	4,4	217	784
		195	4,3	215	760
		200	4,2	214	752
		205	4,1	211	730
		210	4,0	210	730
		215	4,0	208	725
		220	3,9	207	722
		225	3,8	206	733
		230	3,7	207	737
		235	3,6	207	738
		240	3,5	206	744
		245	3,5	206	748
		250	3,4	206	754
		255	3,3	207	758
		260	3,2	207	767
		265	3,1	207	722
		270	2,9	205	718
		275	2,8	203	715
		280	2,9	202	714
		285	2,8	202	709
		290	2,7	202	706
		295	2,6	202	705
		300	2,5	203	706
		305	2,4	202	710
		310	2,4	202	711
		315	2,3	202	708
		320	2,2	201	688
		325	2,1	199	686
		330	2,0	197	685
		335	2,0	196	698



Wood Stove Preconditioning

Model: MCR 8362

Date: 2018-07-18

Test Engineer: WENGEL

Total Hours: 54

All fuel is natural untreated wood, 15% to 25% moisture (wet)

Date	Time	ET (min)	Scale (lbs)	Flue Temp (°F)	Cat Temp (°F)
		340	1,9	196	708
		345	1,8	196	721
		350	1,7	197	726
		355	1,6	198	730
		360	1,6	198	724
		365	1,5	198	726
		370	1,4	198	722
		375	1,3	197	723
		380	1,3	198	735
		385	1,2	199	743
		390	1,1	201	755
		395	1,1	202	761
		400	1,0	203	742
		405	0,9	204	734
		410	0,9	203	707
		415	0,8	201	700
		420	0,8	200	697
		425	0,7	199	688
		430	0,7	196	679
		435	19,4	237	422
		440	18,7	296	751
		445	17,8	389	1057
		450	16,8	439	1099
		455	15,8	457	1084
		460	14,9	463	1048
		465	13,9	457	1008
		470	13,2	451	985
		475	12,4	448	986
		480	11,6	447	992
		485	10,8	446	975
		490	10,3	367	893
		495	9,9	323	1046
		500	9,7	300	1044
		505	9,4	288	1085
		510	9,1	283	1127
		515	8,8	281	1138
		520	8,5	279	1135



Wood Stove Preconditioning

Model: MCR 8362

Date: 2018-07-18

Test Engineer: WENGEL

Total Hours: 54

All fuel is natural untreated wood, 15% to 25% moisture (wet)

Date	Time	ET (min)	Scale (lbs)	Flue Temp (°F)	Cat Temp (°F)
		525	8,2	377	911
		530	7,3	360	766
		535	6,7	338	905
		540	6,2	313	946
		545	5,8	293	837
		550	5,6	277	803
		555	5,3	265	798
		560	5,0	257	793
		565	4,8	252	799
		570	4,6	247	786
		575	4,3	241	778
		580	4,1	236	778
		585	4,0	232	757
		590	3,8	228	743
		595	3,7	223	730
		600	3,6	219	721
		605	3,4	216	717
		610	3,3	214	749
		615	3,3	212	728
		620	3,1	211	730
		625	3,0	210	743
		630	2,9	209	732
		635	2,8	207	718
		640	2,7	205	713
		645	2,6	203	723
		650	2,5	202	721
		655	2,4	202	728
		660	2,3	201	733
		665	2,3	202	736
		670	2,2	201	737
		675	2,1	201	714
		680	2,0	199	713
		685	2,0	198	712
		690	1,8	198	704
		695	1,8	198	690
		700	1,7	197	679
		705	1,6	195	677



Wood Stove Preconditioning

Model: MCR 8362

Date: 2018-07-18

Test Engineer: WENGEL

Total Hours: 54

All fuel is natural untreated wood, 15% to 25% moisture (wet)

Date	Time	ET (min)	Scale (lbs)	Flue Temp (°F)	Cat Temp (°F)
		710	1,5	195	678
		715	1,4	194	688
		720	1,4	195	694
		725	1,3	194	700
		730	1,2	194	709
		735	1,2	194	681
		740	1,1	193	681
		745	1,0	194	704
		750	1,0	196	709
		755	0,9	196	701
		760	0,9	196	691
		765	0,8	194	678
		770	0,8	194	683
		775	0,7	195	706
		780	0,6	196	704
		785	0,6	197	699
		790	0,5	196	667
		795	0,4	193	661
		800	0,4	191	659
		805	0,3	189	657
		810	0,3	188	658
		815	0,3	186	647
		820	0,2	184	633
		825	0,2	181	599
		830	0,2	177	583
		835	0,1	173	575
		840	0,1	170	569
		845	0,1	168	565
		850	0,0	166	565
		855	0,0	166	569
		860	0,0	165	570
		865	0,0	164	558
		870	0,0	163	552
		875	0,0	161	550
		880	0,0	160	546
		885	0,0	158	508
2018-07-20	10:56AM	0	6,9	641	1177



Wood Stove Preconditioning

Model: MCR 8362

Date: 2018-07-18

Test Engineer: WENGEL

Total Hours: 54

All fuel is natural untreated wood, 15% to 25% moisture (wet)

Date	Time	ET (min)	Scale (lbs)	Flue Temp (°F)	Cat Temp (°F)
		5	5,9	573	1271
		10	5,0	548	1187
		15	4,3	527	1070
		20	3,8	501	992
		25	3,3	479	929
		30	2,9	463	886
		35	2,6	452	865
		40	10,7	456	665
		40	19,6	389	1016
		45	19,0	349	1002
		50	18,5	332	961
		55	18,1	321	997
		60	17,6	312	1053
		65	17,2	309	1025
		70	16,8	308	1154
		75	16,4	309	1156
		80	16,0	310	1206
		85	15,6	314	1258
		90	14,8	346	934
		95	14,2	318	955
		100	13,7	302	916
		105	13,3	287	933
		110	12,9	294	1228
		115	12,5	301	1234
		120	12,1	304	1233
		125	11,8	303	1220
		130	11,4	301	1200
		135	10,9	364	1081
		140	10,2	376	1048
		145	9,6	377	1012
		150	9,0	369	953
		155	8,5	361	929
		160	8,1	355	923
		165	7,6	348	937
		170	7,1	344	960
		175	6,7	341	981
		180	6,4	334	916



Wood Stove Preconditioning

Model: MCR 8362

Date: 2018-07-18

Test Engineer: WENGEL

Total Hours: 54

All fuel is natural untreated wood, 15% to 25% moisture (wet)

Date	Time	ET (min)	Scale (lbs)	Flue Temp (°F)	Cat Temp (°F)
		185	6,1	326	878
		190	5,9	319	875
		195	5,7	317	876
		200	5,5	312	866
		205	5,3	309	911
		210	5,2	304	870
		215	5,1	297	843
		220	4,9	291	826
		225	4,8	286	811
		230	4,7	282	807
		235	4,6	280	801
		240	4,5	278	798
		245	4,4	275	785
		250	4,3	273	790
		255	4,1	273	790
		260	4,0	270	793
		265	3,9	270	796
		270	3,8	269	796
		275	3,7	269	800
		280	3,6	269	801
		285	21,2	344	997
		290	20,9	287	866
		295	20,4	290	1031
		300	19,9	307	1149
		305	19,5	305	993
		310	19,1	298	991
		315	18,7	296	910
		320	18,1	301	898
		325	17,6	308	979
		330	16,9	318	986
		335	16,2	326	1012
		340	15,6	321	1014
		345	14,9	327	1065
		350	14,3	334	1074
		355	13,7	334	1084
		360	13,1	324	921
		365	12,8	309	866



Wood Stove Preconditioning

Model: MCR 8362

Date: 2018-07-18

Test Engineer: WENGEL

Total Hours: 54

All fuel is natural untreated wood, 15% to 25% moisture (wet)

Date	Time	ET (min)	Scale (lbs)	Flue Temp (°F)	Cat Temp (°F)
		370	12,2	299	854
		375	11,8	293	841
		380	11,4	288	831
		385	11,0	283	817
		390	10,6	280	817
		395	10,3	280	818
		400	9,9	279	818
		405	9,6	277	824
		410	9,2	275	809
		415	8,8	271	814
		420	8,5	269	840
		425	8,2	266	827
		430	7,9	262	841
		435	7,7	260	853
		440	7,5	257	847
		445	7,3	250	827
		450	7,2	243	810
		455	7,0	237	795
		460	6,9	232	781
		465	6,8	227	774
		470	6,6	223	767
		475	6,5	220	771
		480	6,4	218	776
		485	6,3	218	785
		490	6,2	217	774
		495	6,1	217	779
		500	6,0	216	772
		505	5,9	215	750
		510	5,8	213	730
		515	5,7	211	726
		520	5,6	209	720
		525	5,5	206	717
		530	5,5	204	723
		535	5,4	204	734
		540	5,3	204	737
		545	5,2	204	737
		550	5,1	204	743



Wood Stove Preconditioning

Model: MCR 8362

Date: 2018-07-18

Test Engineer: WENGEL

Total Hours: 54

All fuel is natural untreated wood, 15% to 25% moisture (wet)

Date	Time	ET (min)	Scale (lbs)	Flue Temp (°F)	Cat Temp (°F)
		555	5,0	204	739
		560	4,9	204	745
		565	4,8	205	746
		570	4,7	205	745
		575	4,7	205	736
		580	4,6	204	730
		585	4,5	203	714
		590	4,4	202	714
		595	4,3	200	716
		600	4,2	198	716
		605	4,1	198	723
		610	4,1	198	724
		615	4,0	198	731
		620	3,9	198	726
		625	3,8	197	720
		630	3,7	197	722
		635	3,7	197	705
		640	3,6	196	708
		645	3,6	196	719
		650	3,5	196	718
		655	3,4	197	730
		660	3,4	197	726
		665	3,3	197	728
		670	3,2	196	711
		675	3,1	196	726
		680	3,0	197	735
		685	3,0	197	726
		690	2,9	197	720
		695	2,8	196	719
		700	2,7	197	730
		705	2,6	197	732
		710	2,6	197	731
		715	2,5	197	727
		720	2,4	197	722
		725	2,3	197	731
		730	2,3	198	720
		735	2,2	196	698



Wood Stove Preconditioning

Model: MCR 8362

Date: 2018-07-18

Test Engineer: WENGEL

Total Hours: 54

All fuel is natural untreated wood, 15% to 25% moisture (wet)

Date	Time	ET (min)	Scale (lbs)	Flue Temp (°F)	Cat Temp (°F)
		740	2,1	196	696
		745	2,1	195	681
		750	2,0	193	672
		755	1,8	191	673
		760	1,9	190	670
		765	1,8	189	672
		770	1,7	189	658
		775	1,7	188	668
		780	1,6	187	660
		785	1,6	186	666
		790	1,5	186	657
		795	1,5	184	635
		800	1,4	182	617
		805	1,4	180	630
		810	1,3	180	632
		815	1,3	180	626
		820	1,2	179	625
		825	1,2	177	585
		830	1,2	175	563
		835	1,2	170	531
		840	1,1	166	518
		845	1,1	161	501

APPENDIX 5: Participants

Danick Power ing.
v-p operation
Services Polytests inc.
450.741.3636
www.polytests.com

Maxime Martin
Technicien
Services Polytests inc.
450.741.3636
www.polytests.com

Bill Engel
Senior Product Development Engineer
Hearthstone QHHP
317 Stafford Ave
Morrisville, VT 05661
802 851 4231

APPENDIX 6: Drawings and specifications

APPENDIX 7: Operator's manual



Manchester

(Model 8362)

Woodstove

OWNER'S MANUAL

Installation And Operating Instructions



We recommend that our products be installed and serviced by professionals who are certified in the U.S. by NFI (National Fireplace Institute).

www.nficertified.org



**SAVE THIS OWNER'S MANUAL
FOR FUTURE REFERENCE**

**PLEASE READ THIS ENTIRE OWNER'S MANUAL BEFORE YOU INSTALL AND USE YOUR
NEW MANCHESTER 8362 WOOD STOVE.**

If this room heater is not properly installed, a house fire may result.

To reduce the risk of fire, follow the installation instructions.

Failure to follow these instructions can result in property damage, bodily injury, or even death.

Conforms to UL Std. 1482

Certified to ULC Std. S627

**CONTACT LOCAL AUTHORITIES WITH JURISDICTION (BUILDING DEPARTMENT or FIRE
OFFICIALS), ABOUT PERMITS REQUIRED, RESTRICTIONS AND INSTALLATION
INSPECTION IN YOUR AREA.**

California Prop 65

⚠ WARNING: This product can expose you to chemicals including glass wool fiber and carbon monoxide which are known to the State of California to cause cancer, birth defects or other reproductive harm. For more information go to www.P65Warnings.ca.gov

NOTES ON STOVE OPERATION AND EFFICIENCY

Rating:

You have purchased a Manchester 8362 tested to EPA Method 28R 40 CFR Part 60 where applicable. This stove is certified to comply with the U.S. Environmental Protection Agency 2020 particulate emissions standard using crib wood. It is certified at 0.65 gr/hr. emission rate and under specific test conditions has been shown to deliver heat at rates ranging from 14000 to 33000 Btu (output).

This wood heater has a manufacturer-set minimum allowable low burn rate that must not be altered. It is against federal regulations to alter this setting or otherwise operate this wood heater in a manner inconsistent with operating instructions in this manual.

Please refer to the Warranty section of this manual for registration instructions. In case of warranty claims, please contact the point of original sale or the nearest authorized Hearthstone dealer. Our dealer network processes all warranty claims. Authorized Hearthstone dealers can be located at www.hearthstonestoves.com.

This heater is designed to burn natural wood only. Higher efficiencies and lower emissions generally result when burning air-dried seasoned hardwoods, as compared to softwoods or to green or freshly cut hardwoods. **DO NOT BURN:** *Garbage, lawn clippings, material containing rubber (including tires), materials containing plastic, waste petroleum products paints or paint thinners, asphalt products, materials containing asbestos, construction or demolition debris, railroad ties, pressure treated wood, manure or animal remains, salt water driftwood or other previously salt water saturated materials, unseasoned wood, paper products, cardboard, plywood or particleboard.* This prohibition against burning these materials does not prohibit the use of fire starters made from paper, cardboard, sawdust, wax and similar substances for the purpose of starting a fire in an affected wood heater. Burning these materials may result in a release toxic fumes or render the heater ineffective and cause smoke.

Following the maintenance guidelines set forth in this manual will help insure the efficient use of your wood heater and minimize visible emissions. Having your stove inspected by a trained professional on a regular basis will greatly increase the potential for recognizing potential impacts to efficiency.

Proper draft is important to the efficient operation of your heater. Refer to the Normal Operation section of this manual for information regarding adequate draft. Both excessive and sub-minimum draft can affect the efficiency of your wood heater. Excessive draft can lead to over-consumption of fuel, lower overall heating capacity of the stove and potential over firing. Low draft can result in inefficient burns, low heat output, expulsion of smoke into the living area when stove doors are opened and an increased potential for build-up of flammable materials in the flue.

Efficiency:

Efficiency was measured and weighted using EPA Method 28R and CSA B415-10 methodology. A weighted average was used to calculate the overall efficiency across all of the 4 burn rate categories using the higher heating value (HHV). The weighted average efficiency is 78% (HHV).

To maximize the efficiency of your wood stove make sure it is sized properly for the space you plan to heat. An oversized stove will often be forced to burn at a lower and dirtier burn rate. Consult with your dealer for sizing and correctly placing the stove in your home. An incorrectly placed stove can greatly reduce efficiency. Maximizing the efficiency of your stove will heat your house quickly, burn cleaner and use less wood.

Refer to the Choosing Firewood section of this manual for appropriate fuel selection. Seasoned firewood is typically at or near 20% moisture content. This can be measured with any number of hand-held moisture meters available through your local hearth shop. Follow instructions included in the meter you purchase to measure fuel wood moisture content. Burn only dry, seasoned wood as using wet wood will greatly reduce your efficiency.

CO Emissions:

The Manchester 8362 has the following CO emission rates by burn level: Category 1 (low) –40.46 g/hr., Category 2 (med. low) – 37.04 g/hr., Category 3 (med. high) – 63.46 g/hr. and Category 4 – 79.04 g/hr. Wet wood or unapproved fuel described above can greatly affect the emissions of a wood burning stove.

Smoke/Fire/CO Detectors:

It is highly recommended that smoke and CO detectors be installed throughout the heated space when a wood burning heater is installed. Be certain to install these devices not only in the area where the wood appliance is located, but also in bedrooms, hallways leading to other areas of the house and all common areas of the heated space. Check the batteries in these devices and assure operation by performing whatever test operations are recommended by the manufacturer.

TABLE OF CONTENTS

INTRODUCTION	4
CODES.....	5
SAFETY INFORMATION	5
PERIODIC CHECKLIST	6
EMERGENCY PROCEDURES	6
SPECIFICATIONS	7
INSTALLATION	8
UNPACKING.....	8
PACK LIST.....	8
INSTALLING YOUR STOVE	8
HEARTH REQUIREMENTS & FLOOR PROTECTION.....	9
COMBUSTIBLE SURFACE REQUIRED CLEARANCES	10
CHIMNEY CONNECTOR SYSTEMS AND CLEARANCES FROM COMBUSTIBLE WALLS.....	12
OUTSIDE AIR SUPPLY	13
VENTING COMPONENTS & CONFIGURATION REQUIREMENTS.....	14
INSTALLING IN A MOBILE HOME.....	18
OPERATION	19
CONTROLS AND FEATURES	19
BUILDING A FIRE	22
BREAKING IN YOUR WOOD STOVE	22
NORMAL OPERATION	23
CATALYTIC COMBUSTOR OPERATION	24
MAINTENANCE	26
REPLACING THE BAFFLE.....	26
INSPECTING THE CATALYSTS	26
REPLACING THE CATALYSTS.....	27
GLASS REPLACEMENT PROCEDURES	28
CREOSOTE FORMATION & REMOVAL	28
GASKETS	29
TROUBLESHOOTING	30
TROUBLESHOOTING GUIDE	31
REPLACEMENT PARTS & OPTIONAL ACCESSORIES.....	33
SAFETY LABEL	34
WARRANTY	35

INTRODUCTION

Thank you for purchasing a Manchester 8362 woodstove from Hearthstone Quality Home Heating Products. This stove will provide years of comfortable heat. This stove combines the warmth and comfort of soapstone and cast iron with the efficiency of advanced catalytic technology. The Manchester 8362 blends modern technology with the unique beauty and qualities of cast iron. We trust that you will appreciate the quality of this handcrafted product.

Your Manchester 8362 woodstove burns very efficiently, and produces a large amount of heat. However, you should not consider your Manchester 8362 the primary heat source for your home. The Manchester 8362's large glass window allows you to enjoy the fire from a variety of locations in the room.

Please read this manual in its entirety. Its purpose is to familiarize you with your stove's safe installation, proper break-in, operation and maintenance. It contains extremely important information so keep it handy and refer to it often.

A qualified heating technician may need this owner's manual as a reference when installing this stove in your home. There are national, state, and local building codes that direct the technician on how to install your stove. These codes stipulate the dimension of stovepipe and clearances to walls, ceilings, hearth, and other combustible surfaces. The codes exist to reduce the risk of fire. Failure to follow these instructions can result in fire, property damage, bodily injury, and even death.

Install the stove in a safe, open area, away from traffic flow, doors, and hallways. If possible, try to install the stove near an existing chimney and chimney connector. It is extremely important to install this stove with the proper clearance from combustible surfaces. You can purchase specific connector pipe and special wall coverings as specified by this manual and the NFPA 211 code to protect combustible surfaces. As a general rule, keep furniture, drapes, curtains, wood, paper, and other combustibles at least 36 inches (92 cm) away from the stove. Never install the stove in or near a storage location for gasoline, kerosene, charcoal lighter fluid or any other flammable liquids.

Install the stove in your central living area to allow heat to radiate naturally to distant rooms. Do not install your stove in a poorly insulated area. This is inefficient and would likely result in higher fuel usage.

- **SAFETY NOTICE:**

AN IMPROPERLY INSTALLED STOVE CAN RESULT IN A HOUSE FIRE. FOR YOUR SAFETY, CAREFULLY FOLLOW THE INSTALLATION DIRECTIONS. CONTACT LOCAL BUILDING OR FIRE OFFICIALS ABOUT RESTRICTIONS AND INSTALLATION INSPECTION IN YOUR AREA.

The safety of your stove will depend on many factors, some of which include: distance to combustible objects, correct venting, and adequate chimney maintenance. Should you have any questions, do not hesitate to contact your dealer for additional information.

Contact your dealer for any necessary warranty service.

This Manchester Model 8362 stove is warranted by:

Hearthstone Quality Home Heating Products, Inc®
317 Stafford Ave.
Morrisville, Vermont 05661, USA
www.Hearthstonestoves.com

CODES

When you install your Manchester 8362 woodstove, it is imperative that you adhere to all Federal and local codes. Obtain these codes from either of the following sources:

American National Standards Institute, Inc. (ANSI)
1430 Broadway
New York, NY 10018
www.ansi.org

National Fire Protection Association, Inc. (NFPA)
Battery March Park
Quincy, MA 02269
www.nfpa.org

If you are installing your Manchester 8362 in a mobile or manufactured home, follow the guidelines described in the Manufactured Home Construction and Safety Standard, Title 24 CFR, Part 3280 (United States).

SAFETY INFORMATION

Read and understand this Owner's Manual thoroughly before installing and using this stove.

Make sure to install your stove:

- According to the manufacturer's recommendations
- In accordance with all applicable codes
- With the proper sized chimney

When using your stove, follow these safety precautions:

- **Never** modify this stove in any way.
- **Never** burn kiln dried, painted or treated wood in this stove.
- **DO NOT BURN GARBAGE.** **Never** burn garbage or trash, colored or glossy paper, solvents, plywood, artificial logs, cardboard, or driftwood, in this stove.
- **Never** burn coal in this stove.
- **DO NOT BURN FLAMMABLE FLUIDS.**
- **DO NOT USE CHEMICALS OR FLUIDS TO START THE FIRE.** **Never** use gasoline, kerosene, charcoal lighter fluid, or other flammable fluids to start or invigorate the fire. These fuels will cause dangerous burning conditions in the stove. Keep all such materials away from the stove.

- **Never** use a wood grate or other device to elevate the fire.
- **Never** allow logs in the firebox to hit the glass when the door is closed.
- **Never** slam the door or use the door to force wood in to the stove.
- **Never** over-fire your stove. (See page 24)
- **Never** put articles of clothing or candles on a hot stove.
- **Never** connect the stove to a flue used by another appliance.

Other safety guidelines:

- Keep all combustible items such as furniture, drapes, clothing, and other items, at least 36" (0.92 m) from the stove (See page 9)
- Install a smoke detector, preferably in an area away from your wood stove.
- Keep a fire extinguisher handy. We recommend the type rated "A B C."
- Dispose of ashes properly. (See page 25)
- Keep children and pets away from the stove when it is burning; they could be seriously injured by touching a hot stove.
- Clean your chimney system as needed. (See page 29)
- Outside combustion air may be required if:
 1. This solid-fuel-fired appliance does not draw steadily, smoke rollout occurs, fuel burns poorly, or back-drafts occur whether or not there is combustion present.
 2. Existing fuel-fired equipment in the house, such as fireplaces or other heating appliances, smell, do not operate properly, suffer smoke roll-out when opened, or back-draft whether or not there is combustion present.
 3. Opening a window slightly on a calm (windless) day alleviates any of the above symptoms.
 4. The house is equipped with a well-sealed vapor barrier and tight fitting windows and/or has any powered devices that exhaust house air.
 5. There is excessive condensation on windows in the winter.
 6. A ventilation system is installed in the house.

If these or other indications suggest that infiltration air is inadequate, additional combustion air should be provided from the outdoors. Outside combustion air can be provided to the appliance by using the optional outside air kit #93-53500

PERIODIC CHECKLIST

Perform each of these tasks at the specified intervals.

At the End of Every Week:

- Empty ashes from the firebox, sooner if the firebox is full.

At the Beginning of Every Other Month:

- Depending upon your use of the stove, visually inspect the chimney connector and chimney for creosote. (see page 29)
- Check door seals using the "dollar bill test." - When the stove is cool, shut the door on a dollar bill. If the bill pulls out without any resistance, then your stove's door is not sealing properly. To tighten the seal, adjust the door latch mechanism or change the door gasket. (Refer to page **Error! Bookmark not defined.**)
- Inspect the face of the catalytic combustor for fly ash and soot. Use a soft-bristled brush to remove if present. It is recommended to visually inspect the catalytic combustor at least 3 times during the heating season, or every 2-3 months.

At the End of Every Season:

- Dismantle the chimney connector and clean it thoroughly. Replace any pieces that show signs of rust or deterioration.
- Inspect and, if necessary, clean your chimney.
- Clean out the inside of the stove thoroughly.
- Check and clean the catalytic combustor, if necessary
- Inspect all door gasket material and replace if worn, frayed, cracked or extremely hard.

EMERGENCY PROCEDURES

If you have a stovepipe or chimney fire, follow these instructions:

1. If the fire is too threatening, leave the area and call the fire department immediately! If not, perform the next three steps.
 2. Close the primary air control.
 3. Close the stovepipe damper (if present).
 4. Close the bypass damper
 5. Keep the stove front door closed!
- **WARNING: DO NOT ATTEMPT TO PUT OUT A STOVEPIPE OR CHIMNEY FIRE BY THROWING**

WATER ONTO THE STOVE, STOVEPIPE, OR CHIMNEY. THE EXTREMELY HIGH TEMPERATURE OF SUCH FIRES CAN CAUSE INSTANTANEOUS STEAM AND SERIOUS BODILY HARM.

Once the chimney fire expires, leave the primary air control and bypass handle closed and let the fire in the stove die out completely. Inspect the stove, stovepipe, and chimney thoroughly for any sign of damage before firing the stove again. You must correct any damage before using your stove again.

Establish a routine for the fuel, wood burner and firing technique. Check daily for creosote build-up until experience shows how often you need to clean to be safe. Be aware that the hotter the fire the less creosote is deposited, and weekly cleaning may be necessary in mild weather even though monthly cleaning may be enough in the coldest months. Contact your local municipal or provincial fire authority for information on how to handle a chimney fire. Have a clearly understood plan to handle a chimney fire.

SPECIFICATIONS

Maximum Heat Output:

75,000 BTUs per hour of cordwood (based on independent laboratory test results).

Floor Size of Heated Area:

Up to a maximum of 2,400 square feet. Factors unique to your home can reduce the square footage the stove will heat. Home insulation value, number and efficiency of windows, floor plan, stove placement, quality of the fuel and other conditions may limit the heating ability of the stove.

Firebox Capacity:

2.45 cubic feet.

Maximum Log Length: Up To 24" (61cm) through side door.

Emissions: 0.65 g/hr.

Burn Time: Up to 30+ hrs. (*Heat Life™*: Up to 30 hours) Note: The amount and weight of wood contained per cubic foot of firebox volume can vary from 10 to 25 lbs. per cubic foot depending on type of wood, moisture content, packing density and other factors.

Stove Dimensions:

Height: 32 1/8" (81.6cm)
Width: 30 1/4" (76.8cm)
Depth: 20" (50.8cm)
Weight: 520 lbs. (236 kg)

Connector Size: 6" (152 mm) diameter
Metal Chimney: 6" (152 mm) inside diameter
Masonry Chimney: 6" (152 mm) inside diameter (round flue), 8" x 8" (203 x 203 mm) (square flue)

Crate Dimensions:

H-49.5" W-32.4" L-24.5" or 126x82.3x62.2cm (add 4" or 10.2cm for pallet).

Optional Equipment:

Outside Air Kit	93-53500
Blower Kit	93-57600
Spark Screen	93-69600
Close Clearance Heat Shield	93-68600

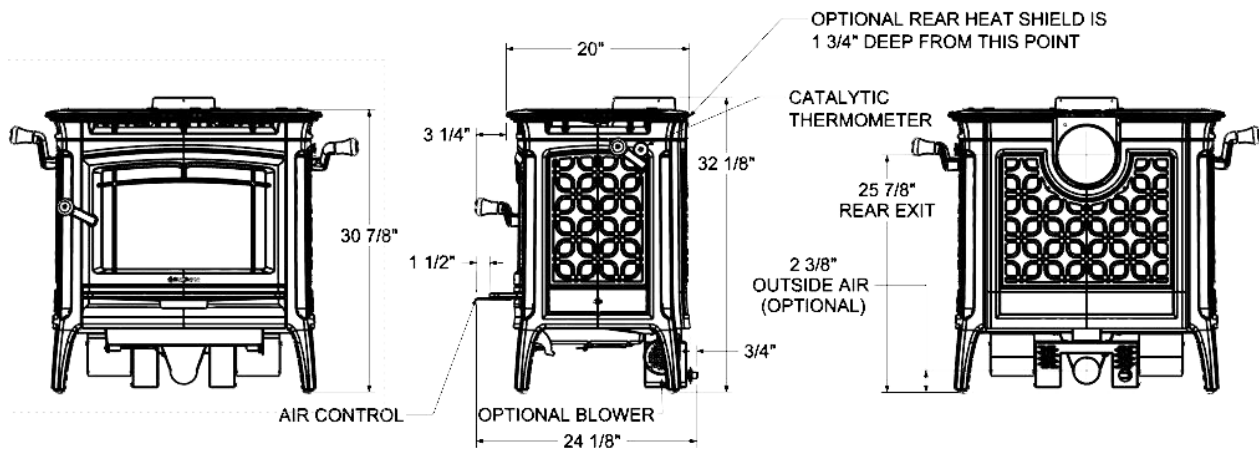
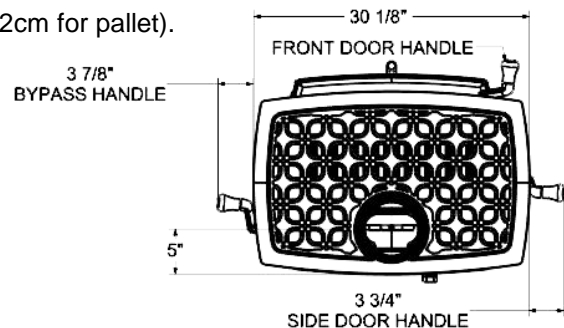

Figure 1 – Manchester 8362 Dimensions

INSTALLATION

UNPACKING

Hearthstone packages your Manchester 8362 woodstove with the greatest care so that it ships safely. Under certain circumstances, however, damage may occur during transit and handling. When you receive the Manchester 8362, carefully unpack and inspect the stove and all accompanying parts. Ensure that all parts are included with the stove. If any parts are damaged or missing, please contact your authorized Hearthstone dealer immediately.

PACK LIST

Manchester Model 8362 Woodstove
Owner's Manual
Bag of Handles and Hardware

The label is attached by a cable to the bottom of the stove. Take care when lifting the stove not to damage the label or cable. After final positioning of the stove, the label may be stored in the holding clip on the bottom shield of the stove.

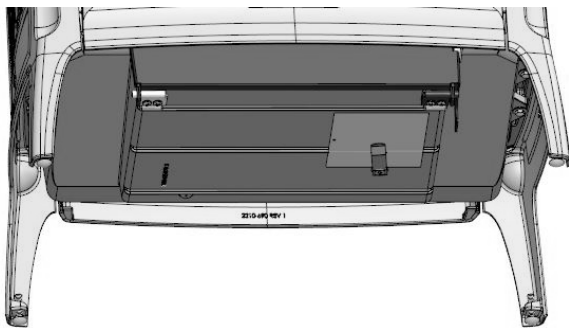

Figure 2 - Label Location

INSTALLING YOUR STOVE

Choose a place to install your Manchester 8362 woodstove. Consider the location of your stove for optimum heating efficiency. In general, it is better to place your stove in a main living area, rather than in a basement or other confined space.

Inspect this location to make sure that the stove and stovepipes will have the required clearance from combustible materials that are near the stove. Combustibles include walls, floor, ceiling, and chimney chase. You must carefully consider the clearances to all of these combustibles before actually connecting your stove.

If the floor is made of combustible material, then a non-combustible floor protector is required between the floor and the stove. An example of a non-combustible floor protector is a hearth constructed with a continuous layer of tile, brick, slate, glass or another non-combustible facing. There is no R-value requirement.

If you use a rear connector pipe, ensure it is listed with Underwriter's Laboratories. Check the listing of your pipe with UL for the correct clearances.

The diagrams in this manual represent typical installations, but are specific to the Simpson Dura-Vent DVL brand.

Clearances to NFPA Code 211 Protected Surfaces

You can reduce the clearances to combustible surfaces by using any National Fire Protection Agency (NFPA) approved wall protection system with additional approval of the regulatory authority having jurisdiction in your area. Please refer to NFPA Code 211 for specifications and complete details. You can obtain this information directly from the NFPA.

National Fire Protection Agency

Batterymarch Park
Quincy, MA 02269
1-800-344-3555
1-617-770-3000
www.nfpa.org

HEARTH REQUIREMENTS & FLOOR PROTECTION

Ensure you protect combustible flooring with a covering of noncombustible material. The Manchester 8362 does not require an insulated hearth pad. The minimum floor protection must be met under the stove and extend beyond the stove as follows:

The minimum floor protection for US installations is 48in x 36-3/4in.
 The minimum floor protection for installations in Canada is 56in x 44in.

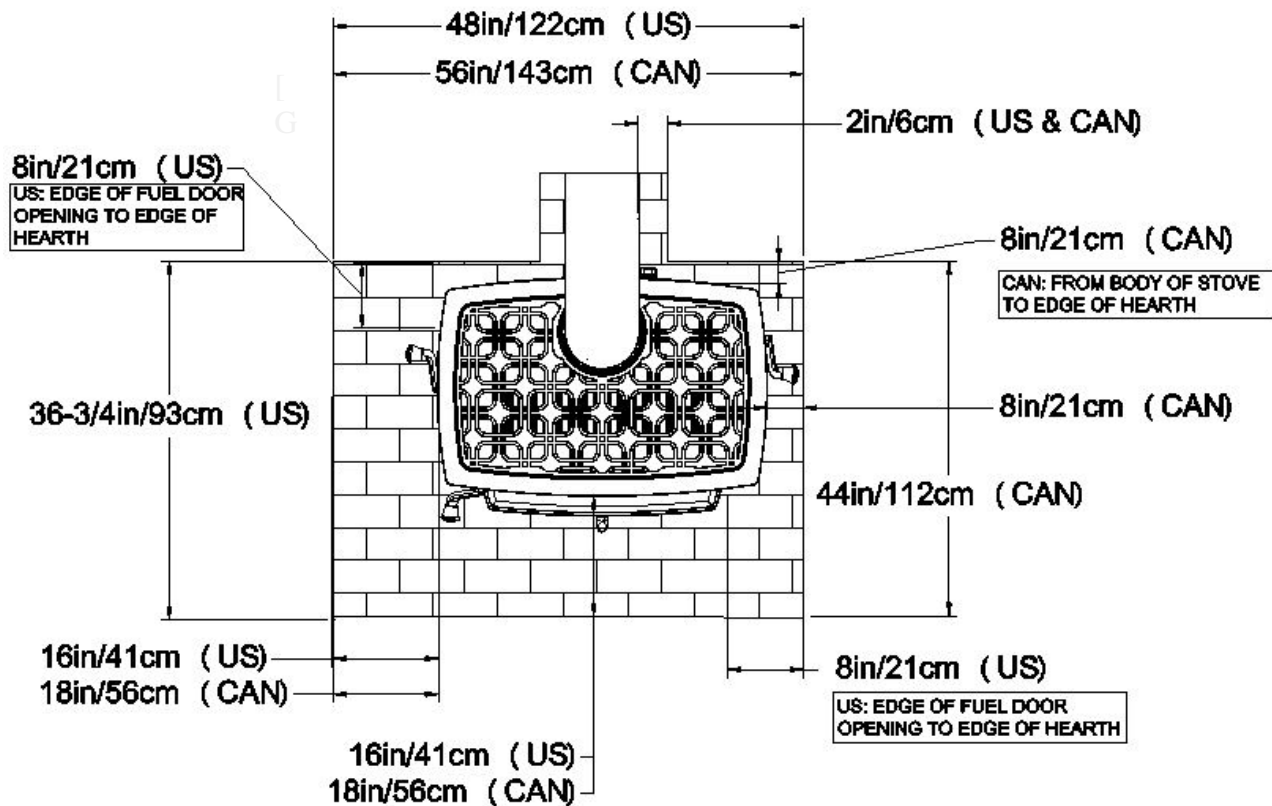

Floor Protection

Figure 3 – Hearth Dimensions

COMBUSTIBLE SURFACE REQUIRED CLEARANCES

Note: Dimensions shown in the following figures are from the body of the stove unless otherwise indicated.

It is very important to follow minimum clearances for chimney connectors to combustibles such as walls and ceilings when installing the stove near combustible surfaces.

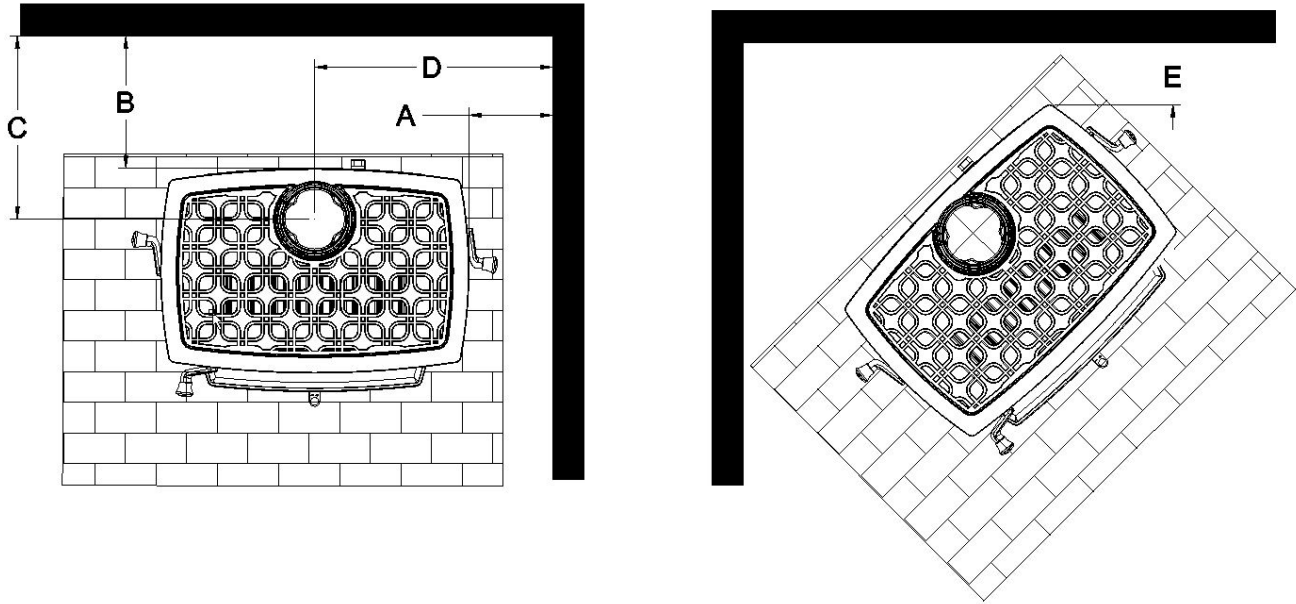

Figure 4 – Clearance to Combustibles

Clearances	Parallel				Corner
	A	B	C	D	E
Single wall Connector – No Close Clearance Heat Shield	18"-46cm	16"-41cm	21"-54cm	33.625"-86cm	9"-23cm
Single Wall Connector – With Close Clearance Heat Shield	18"-46cm	10"-26cm	15"-39cm	33.625"-86cm	9"-23cm
Double Wall Connector – No Close Clearance Heat Shield	16"-41cm	16"-41cm	21"-54cm	31.625"-81cm	9"-23cm
Double Wall Connector – With Close Clearance Heat Shield	16"-41cm	6"-16cm	11"-28cm	31.625"-81cm	9"-23cm

Alcove Clearances (inches)	Unprotected Surfaces	Protected Surfaces (NFPA-211)
Minimum alcove width	62.25" – 159cm	See NFPA-211
Maximum alcove depth	52" – 132	See NFPA-211
Min. Alcove ceiling from floor with single wall connector	68" – 173cm	See NFPA-211
Min. Alcove ceiling from floor with double wall connector	61.5" – 163cm	See NFPA-211

FOR BLOWER KIT, USE KIT #93-57600

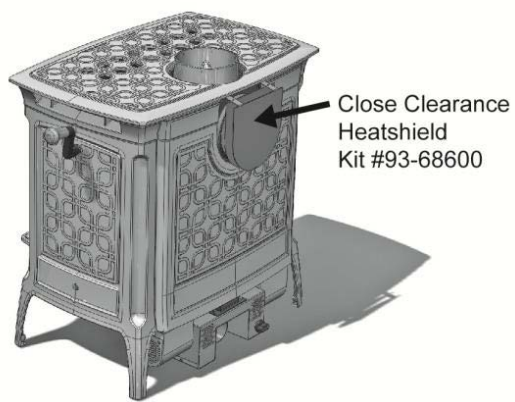
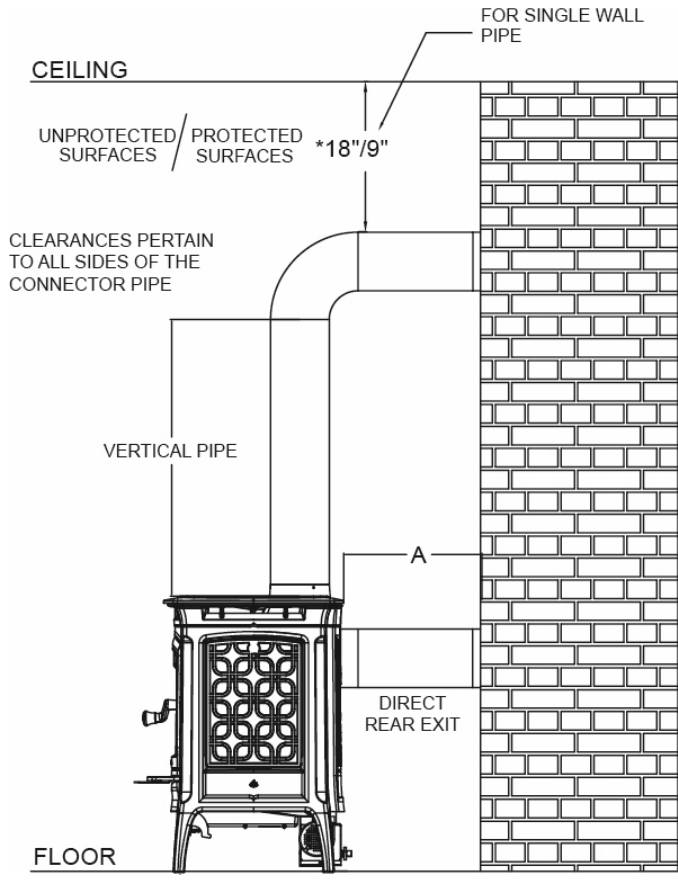
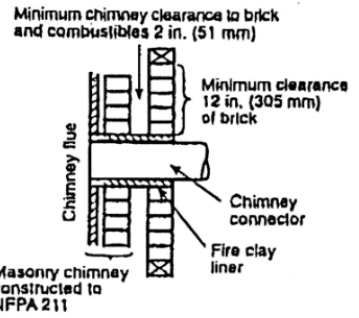
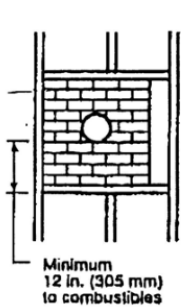

Figure 5 Chimney Connector Clearances

Vertical Pipe Length Before Elbow	Single Wall Pipe		Double Wall Pipe	
	With Heat Shield**	Without Heat Shield	With Heat Shield**	Without Heat Shield**
	A	A	A	A
18" or More	10"	16" (41 cm)	6"	16" (41cm)
Less Than 18"	14"	16"	10" (26cm)	16" (41cm)
Direct Rear Exit	N/A	14"	N/A	6"

*For double wall pipe clearance to ceiling, refer to pipe manufacturer specifications.

** Close Clearance Heatshield, kit #93-68600 See Parallel Clearance to Combustibles for clearances to the sides of the stove.



Minimum chimney clearance from masonry to sheet steel supports and combustibles 2 in. (51 mm)

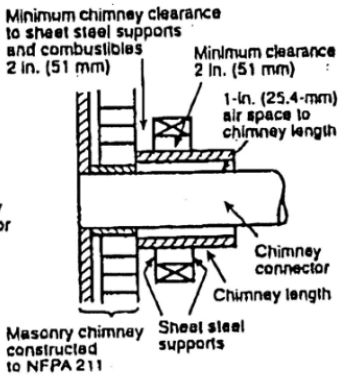
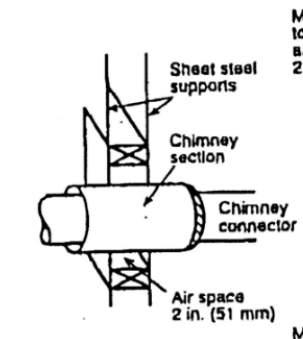
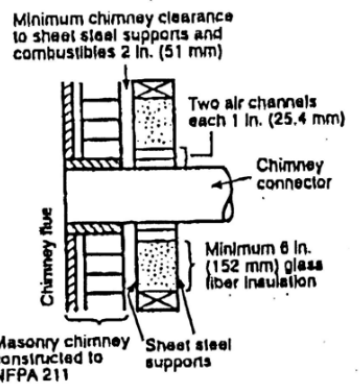
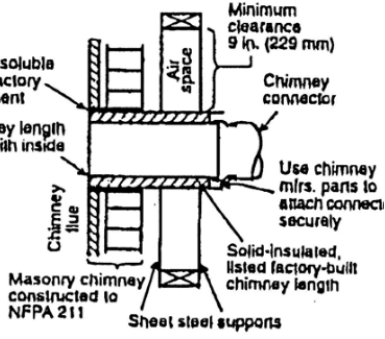
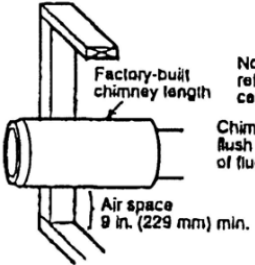

CHIMNEY CONNECTOR SYSTEMS AND CLEARANCES FROM COMBUSTIBLE WALLS FOR RESIDENTIAL HEATING APPLIANCES

- A. Minimum 3.5in thick brick masonry all framed into combustible wall with a minimum of 12in. brick separation from clay liner to combustibles. The fire clay liner shall run from outer surface of brick wall to, but not beyond, the inner surface of chimney flue liner and shall be firmly cemented in place.
- B. Solid-insulated, listed factory-built chimney length of the same inside diameter as the chimney connector and having 1in. or more of insulation with a minimum 9in. air space between the outer wall of the chimney length and combustibles.
- C. Sheet steel chimney connector, minimum 24 gauge in thickness, with a ventilated thimble, minimum 24 gauge in thickness, having two 1in. air channels, separated from combustibles by a minimum of 6in of glass fiber insulation. Opening shall be covered, and thimble supported with a sheet steel support, minimum 24 gauge in thickness.
- D. Solid insulated, listed factory-built chimney length with an inside diameter 2in. larger than the chimney connector and having 1in. or more of insulation, serving as a pass-through for a single wall sheet steel chimney connector of minimum 24 gauge thickness, with a minimum 2in. air space between the outer wall of chimney section and combustibles. Minimum length of chimney section shall be 12in. chimney section spaced 1in. away from connector using sheet steel support plates on both ends of chimney section. Opening shall be covered, and chimney section supported on both sides with sheet steel supports securely fastened to wall surfaces of minimum 24-gauge thickness. Fasteners used to secure chimney section shall not penetrate chimney flue liner.

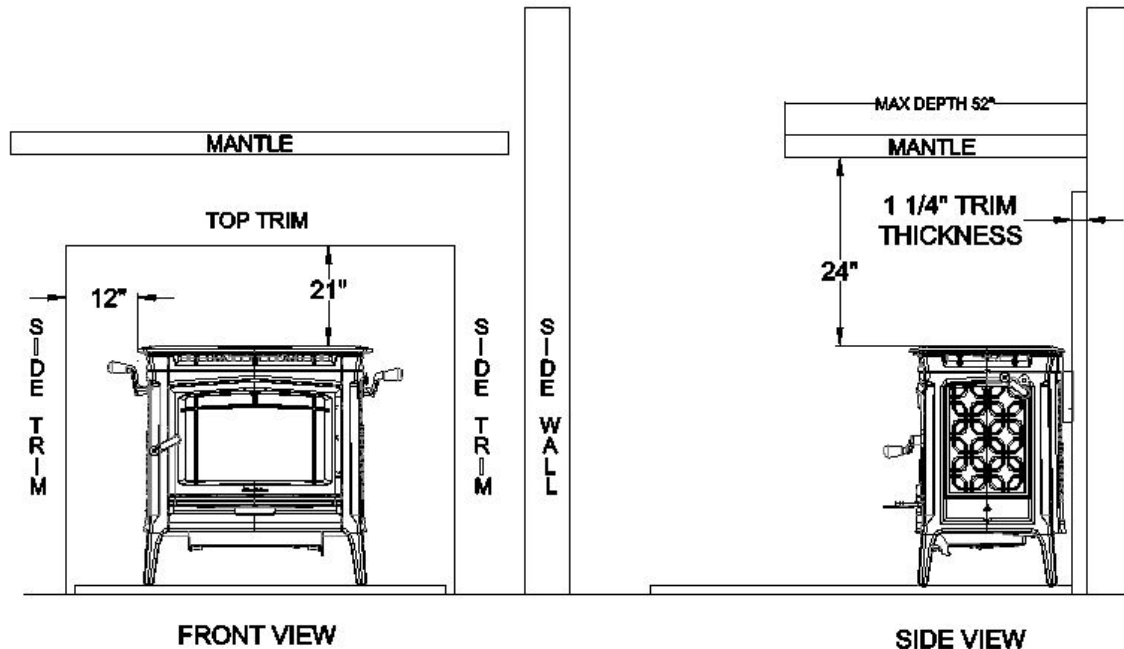

THE SAME CLEARANCES APPLY WITH STOVE IN FIREPLACE ALSO

Figure 6 Trim and Mantle Clearances

OUTSIDE AIR SUPPLY

(Optional Kit #93-53500)

You can connect an outside air source directly to this stove using an optional outside air kit. The advantage of providing outside air directly to the stove is that the air used by the stove for combustion is taken from outside the residence rather than from within the room where the stove is located.

The outside air kit for this stove allows for the direct connection of the stove's air intake to a minimum 3" (76 mm) diameter duct (supplied by others)* which leads to the outside of the house. When considering placement of the duct from the outside of the house to the hearth, keep in mind the need to avoid structural members of the house. The outside air kit attaches to the underside of the stove. Refer to the instructions provided with the kit for installation.

When using an outside air kit in Canada, the stove must be attached to your home's floor. Use the shipping clips that came with the stove and fasteners long enough to attach securely to the subfloor. (The clips and fastener heads may be painted to minimize visibility).

*An adaptor for 4" duct is available if needed. KIT #90-53308

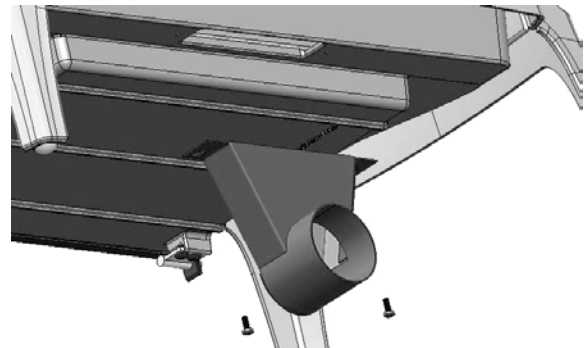

Figure 7 – Outside Air Kit Detail

The International Residential Code (IRC) does not allow the outside air duct to terminate higher than the appliance. Some building officials restrict vertical rise in the duct's termination. Hearthstone recommends the termination be at the same level, or lower than the air intake on the stove.

Locate the termination of the duct on the outside wall of the home in such a manner to avoid the possibility of obstruction by snow, leaves or other material. Screen the termination using 1/4" x 1/4" mesh rodent screen and cover it with a rain/wind proof hood (flex pipe, outside termination, mesh, and hood supplied by others) Contact your dealer for availability.

VENTING COMPONENTS & CONFIGURATION REQUIREMENTS

- **DO NOT CONNECT THIS UNIT TO A CHIMNEY FLUE USED BY ANOTHER APPLIANCE**
- Single wall connector that is at least 24 MSG or 25 MSG blued steel stovepipe.
- Double wall connector (Rear pipe) which is used with a listed, factory-built "Type HT" chimney or with a masonry chimney to reduce clearances, is available from several manufacturers, your dealer can help you choose. Some air insulated connector pipe models available are Simpson Dura Vent DVL and Metalbestos DS. Security, GSW and Ameritec also have acceptable Rear connector pipe.
- When used in a mobile home, a spark arrester is required. (See page 17)
- The chimney connector cannot pass through a floor or ceiling, nor any attic or roof space, closet or similar concealed space. Where venting requires passage through a wall or partition of combustible construction, the installation must conform to NFPA Code 211 or CAN/CSA - B365.
- Be sure to follow the manufacturer's instructions to maintain an effective vapor barrier at the location where the chimney of other component penetrates the exterior of the structure
- It is very important to follow minimum clearances for chimney connectors to combustibles such as walls and ceilings when installing the stove. Typical chimney connector clearances are outlined below. The single wall clearances are generic; the double wall clearances shown are specifically for Simpson DuraVent DVL and may vary with other brands. **Check the specifications from the manufacturer of your connector.**

COMPONENTS OF A VENTING SYSTEM

The complete venting system consists of several components: chimney connector, wall thimble, wall pass-through, chimney, and liner. It is *absolutely necessary* that you install all of these components and maintain the clearances to combustibles discussed earlier to ensure a safe stove installation.

To protect against the possibility of a house fire, you *must properly install and constantly maintain the venting system in good condition. Be sure to inspect*

the chimney and chimney connector and keep it clean. Upon inspection, immediately replace rusted, cracked, or broken components. Failure to follow these instructions and specified components or using make-shift compromises can result in fire, property damage, bodily injury, and even death.

- The *chimney connector* is the stovepipe from the woodstove to the chimney. The chimney connector stovepipe is 6" (152 mm) diameter, 24 MSG or 25 MSG blued steel connector pipe. *Do not use aluminum or galvanized steel pipe* - they cannot withstand the extreme temperatures of a wood fire.
- The *thimble* is a manufactured (or site-constructed) device installed in combustible walls through which the chimney connector passes to the chimney. It keeps the walls from igniting. You must use a wall thimble when installing a chimney connector through a combustible wall to the chimney.
- A *wall pass-through* (or chimney support package) also keeps the walls from igniting. You must use one when connecting through a wall or ceiling to a prefabricated chimney.
- Only install this stove to a *lined masonry chimney* or an *approved high temperature prefabricated residential* type building heating appliance chimney. *Do not* connect this stove to a chimney serving another appliance; you will compromise the safe operation of both the wood stove and the connected appliance.
- A *liner* is the UL 1777 or ULC S635 (for factory built fireplace or masonry) chimney.

You must connect your stove to a chimney comparable to those recommended in this manual. *Do not use stovepipe as a chimney.* Use stovepipe for freestanding installations only to connect the stove to a proper chimney.

- **WARNING: DO NOT CONNECT THIS APPLIANCE TO ANY AIR DISTRIBUTION DUCT OR SYSTEM.**

INSTALLING A VENTING SYSTEM

Attach stovepipe sections to the flue collar and to each other with the crimped end toward the stove. If creosote builds up, this allows the creosote to run into the stove and not on the outside of the stovepipe or onto the stove.

Secure all joints, including attaching the stovepipe to the stove's flue collar, with three sheet metal screws. Install #10 x 1/2" (3 mm x 13 mm) sheet metal screws into the holes pre-drilled in the flue collar. Disregarding the screws can cause joints to separate from the vibrations that result from a creosote chimney fire.

You can simplify connecting stovepipe by using additional accessories such as telescoping pipes, slip-connectors or clean-out tees. These accessories ease the periodic inspection of your chimney, as well as allow you to dismantle the stovepipe easily (without moving the stove).

Install the stove as close as practical to the chimney, while maintaining all proper clearances. Install stovepipe that is as short and as straight as possible. Horizontal runs of stovepipe must always rise away from the stove at a minimum of 1/4" per foot (21mm/m).

We do not recommend long runs of stovepipe to increase heat dispersal. Longer lengths of stovepipe, or more connecting elbows, than necessary increase the chances of draft resistance and the accumulation of creosote buildup.

In general, you do not need to install a stovepipe damper with the Manchester 8362. Some installations, however, could benefit from a stovepipe damper, such as a tall chimney which can create a higher than normal draft. In such cases, a damper can help regulate the draft. The Manchester 8362 requires a draft between 0.06" and 0.1" WC. For drafts above 0.1" WC, install a stovepipe damper. Check the draft at stove installation time.

Remember, the NFPA recommends minimum clearances for chimney connectors to combustibles such as walls and ceilings. Once the stove is installed at safe distances from these combustible surfaces, it is also important to maintain these connector clearances for the remainder of the installation.

CONNECTING THE STOVE TO A CHIMNEY

You can install your Manchester 8362 to a prefabricated metal chimney, or to a masonry chimney.

This room heater must be connected to (1) a listed Type HT (2100° F) chimney per UL 103 or ULC S629, or (2) a code-approved masonry chimney with a flue liner. The chimney size should not be less than the flue collar, or more than three times greater than the cross-sectional area of the flue collar.

We recommend installing a cleanout tee where possible to simplify chimney cleaning and maintenance.

Connecting to a Prefabricated Metal Chimney

There are two ways to install a prefabricated metal chimney:

- An *interior* installation where the chimney passes inside the residence through the ceiling and roof.
- An *exterior* installation where the chimney passes through the wall behind the stove then up the outside of the residence.

Whenever possible, choose an interior chimney. An interior chimney heats up quickly and retains its heat; thus promotes a better draft and discourages the formation of creosote. An exterior chimney does not benefit from the warmth of the building, so it typically operates at lower flue temperatures than an interior chimney and may experience increased creosote accumulation.

When connecting the Manchester 8362 to a prefabricated metal chimney, you must follow, precisely, the manufacturer's installation instructions. Use only Type HT (2100° F), prefabricated metal chimneys listed per UL 103 or ULC S629 standards.

Ensure the size of the prefabricated chimney's flue is appropriate for the Manchester 8362. The Manchester 8362 requires a 6" (152 mm) inside diameter flue for new installations. A 6" diameter flue provides adequate draft and performance. You can use an 8" (203 mm) diameter existing flue with a reducer. An oversized flue contributes to creosote accumulation. (In this case, bigger is NOT better.)

When purchasing a prefabricated chimney to install with your stove, Ensure you also purchase from the same manufacturer the wall pass-through (or ceiling support package), "T" section package, fire-stops (when needed), insulation shield, roof flashing, chimney cap, and any other required accessories. Follow the manufacturer's instructions when installing the chimney and accessories. In addition, ensure you maintain all manufacturers' recommendations for the proper clearances to the chimney.

Connection to a Masonry Chimney

Consider two primary elements when connecting your stove to a masonry chimney: the chimney itself and the thimble where the stovepipe connects to the chimney. **Use only code approved masonry chimneys containing a proper flue liner.**

Before connecting to a masonry chimney, hire a professional to examine the chimney for cracks, loose mortar, and other signs of deterioration and blockage. If the chimney needs repair, complete them before installing and using your stove. Do not install your stove until the chimney is safe for use.

Ensure the chimney's cleanout is complete and working properly. To avoid a loss of draft, the cleanout door must close completely and provide a tight seal. If the cleanout door leaks, the chimney will cool, your stove will perform poorly, and creosote can form.

Ensure the size of the chimney's flue is appropriate for this stove and that it is not too large. Use a masonry chimney with a maximum 6" Diameter or 8" x 8" (203 mm x 203 mm) tile size for best results. An oversized flue contributes to the accumulation of creosote.

Use the following checklist to ensure that your masonry chimney meets these minimum requirements:

MASONRY CHIMNEY WALL CONSTRUCTION:

- Mortared brick or modular block at least 4" (102 mm) thick – must use liner
- A mortared rubble or stone wall – must use liner

FLUE LINER OPTIONS:

- Tile - minimum wall thickness of 5/8" (16 mm), installed with refractory mortar, and with at least 1" (25 mm) air space around the liner
- Stainless steel - III listed 6" diameter insulated

filled with vermiculite or suitable material (these keep the liner warmer for better performance)

- Ensure any equivalent flue liner is a listed chimney liner system meeting type HT requirements or other approved material.

INTERIOR CHIMNEY REQUIREMENTS:

- Must have at least 2" (51 mm) clearance to combustible materials
- Must install fire stops at the spaces where the chimney passes through floors and/or ceiling
- Any insulation material must be at least 2" (51 mm) from the chimney

EXTERIOR CHIMNEY REQUIREMENTS:

- At least 1" (25 mm) clearance to combustible materials

CHIMNEY HEIGHT REQUIREMENTS (SEE FIGURE 9):

- At least 3 feet (0.9 m) higher than the highest part of the roof opening through which it passes.
- At least 2 feet (0.6 m) higher than any part of the roof within 10 feet (3 m) measured horizontally from the top of the chimney.

The recommended minimum chimney height is 10 feet (3 m) off the floor. The recommended maximum chimney height is 30 feet (9m). The Manchester 8362 requires a draft between 0.06" and 0.1" water column. Ensure your chimney is long enough to provide the minimum draft, and use a damper if your installation has a required chimney height that provides too much draft.

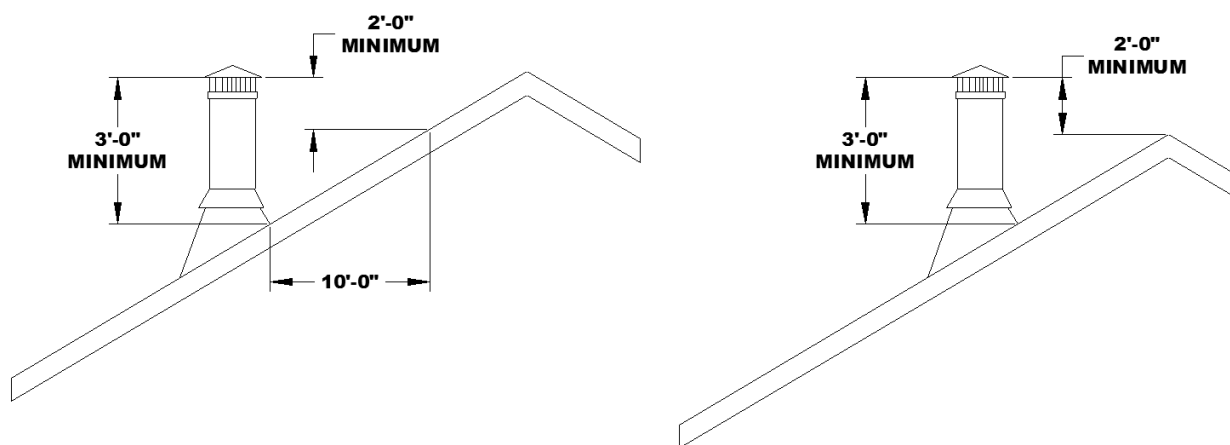
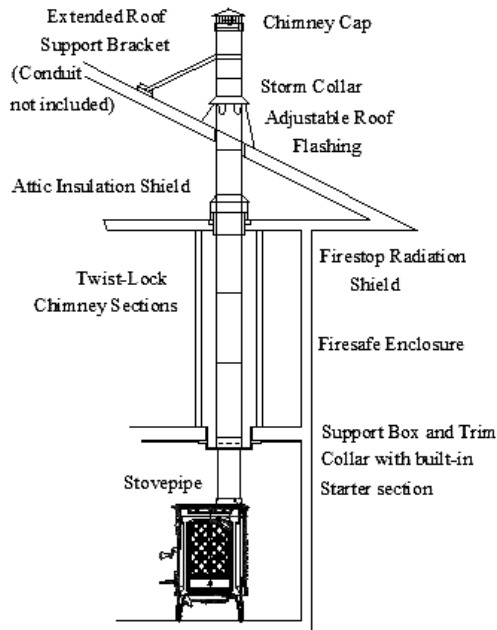
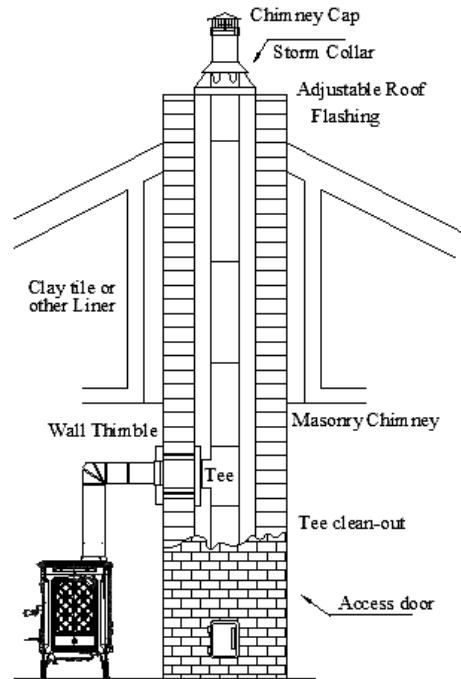

Figure 8 – Chimney Height Requirements



Two story house installation with attic.



Chimney pipe through Clay tile or other Lined Masonry Chimney

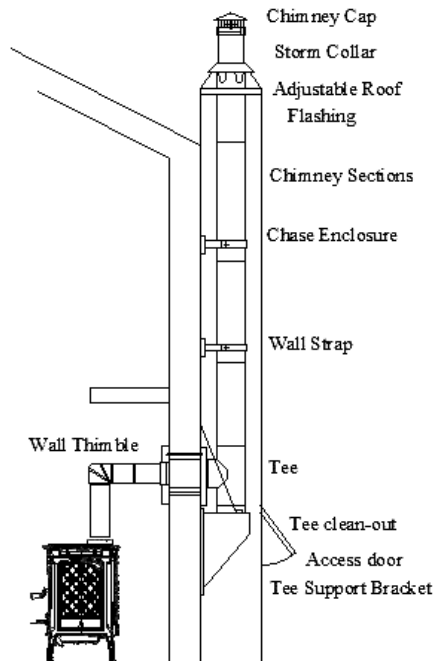

Chimney through outer wall with enclosed chase. Chimney is supported by Tee Support Bracket.

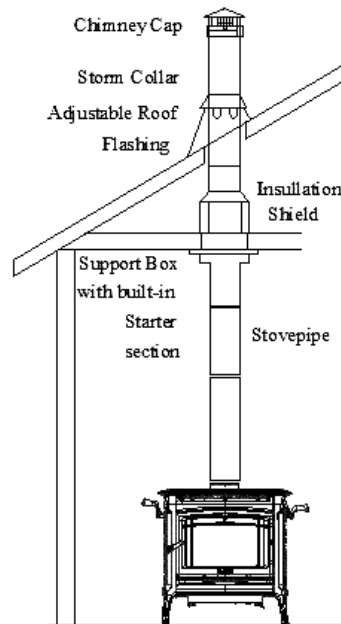

One story house installation with attic. Chimney is supported by Ceiling.

Figure 9 – Typical Chimney Configurations

INSTALLING IN A MOBILE HOME

Follow these special requirements for installing your stove in a mobile home.

- Install the stove in accordance with 24 CFR, Part 3280 (HUD)
- An outside air kit must be used in all mobile home installations. See page 12 for details.
- Permanently attach the stove to your mobile home's floor. Use the shipping clips that came with the stove and fasteners long enough to attach securely to the subfloor. (The clips and fastener heads may be painted to minimize visibility).

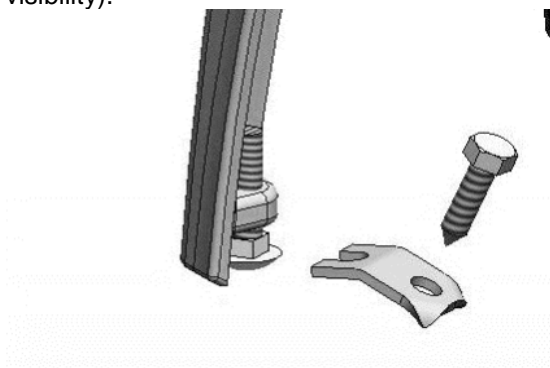

Figure 8 - Lock Down Detail

- Install a Mobile Home Chimney & Connector Kit*.

Each kit must include:

Stainless spark arrester cap, storm collar, Adjustable vented flashing – 0/12 – 6/12, Two 24" chimney pipes, 24" support box with built-in starter section and trim.

* Install a Mobile Home Chimney and Connector Kit conforming to US/UL103 or CAN/ULC-S629, Standard for Factory-Built Chimneys.

- **WARNING: DO NOT INSTALL IN A SLEEPING ROOM IN A MOBILE HOME.**
- **CAUTION: MAINTAIN THE STRUCTURAL INTEGRITY OF THE MOBILE HOME WALLS, FLOOR, CEILING, AND ROOF WHEN INSTALLING AND USING YOUR STOVE.**
- **FAILURE TO FOLLOW THESE INSTRUCTIONS AND SPECIFIED COMPONENTS OR USING MAKE-SHIFT COMPROMISES CAN RESULT IN FIRE, PROPERTY DAMAGE, BODILY INJURY, AND EVEN DEATH.**

- Burning any fuel other than wood in this unit could generate dangerous levels of carbon monoxide within the living space.
- **THE FRONT DOOR MUST REMAIN CLOSED WHEN IN OPERATION EXCEPT FOR START UP AND LOADING.** Leaving the door open during use could cause any smoke or fire detectors in the home to be set off or a fire could escape the firebox and start the room on fire.
- If this unit is installed in a mobile home, care must be taken to ensure adequate air is available. If not enough air is available it could starve the room of all the oxygen. (See page 29 for more details)

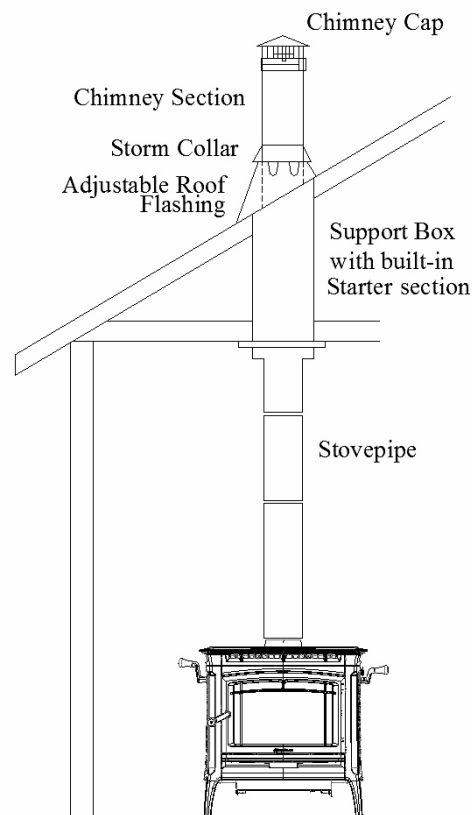

One story house installation with attic.
Chimney is supported by Ceiling.

Figure - 9

- **CAUTION: REMOVE THE CHIMNEY WHEN TRANSPORTING THE MOBILE HOME!**
- Be sure to follow the manufacturer's instructions to maintain an effective vapor barrier at the location where the chimney or other component penetrates the exterior of the structure

OPERATION

Once your Manchester 8362 is installed, you are ready to light a fire.

Every installation, season's firewood, and operator's technique varies. Learn how to use your stove most efficiently for your installation. We can give you the basic principles, but only you can ensure maximizing the potential of your stove while also operating it safely.

- **WARNING: HOT WHILE IN OPERATION! KEEP CHILDREN, PETS, CLOTHING AND FURNITURE AWAY. CONTACT MAY CAUSE SKIN BURNS.**

Read this entire chapter before lighting your first fire. It explains the controls and features of your wood stove, how to choose firewood, and how to use your stove on a daily basis.

CONTROLS AND FEATURES

Before lighting any fires, become familiar with the location and operation of your stove's controls and features and learn how to use them (See *Figure 10*). For your own safety, do not modify these features in any way. We recommend you use fireplace gloves when the stove is in operation and hot.

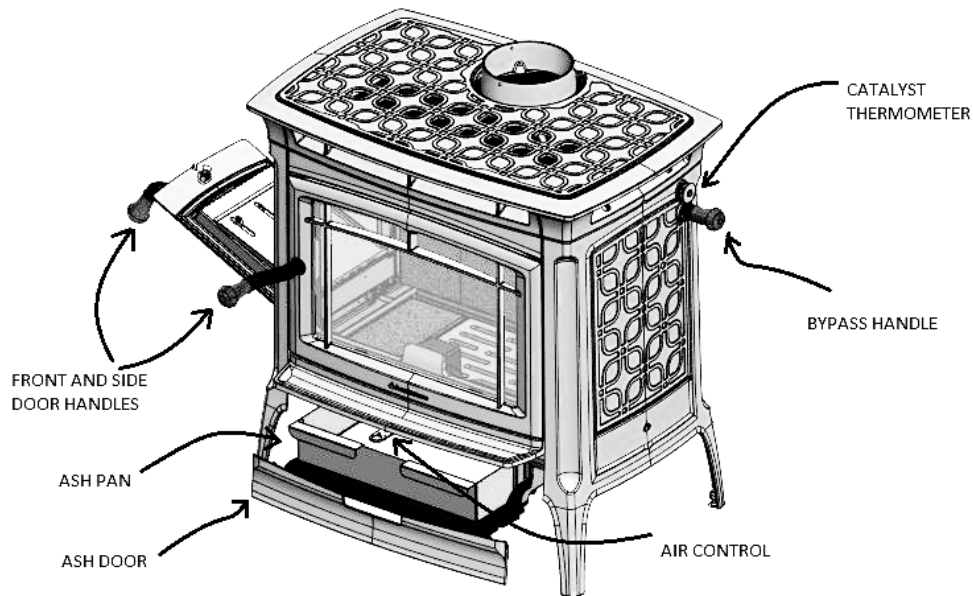
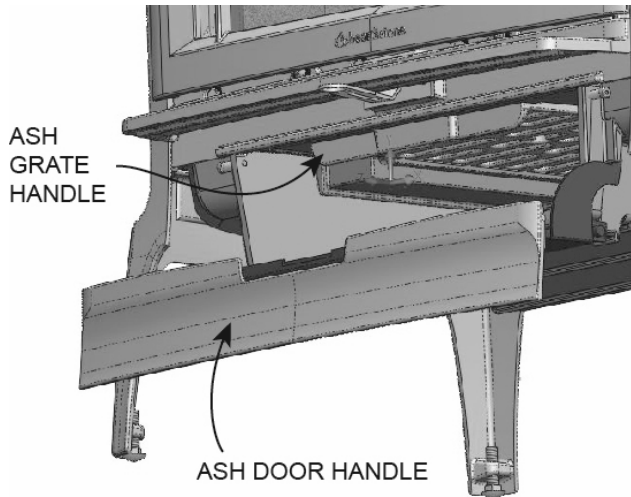

Figure 10 - Controls & Features

FRONT AND SIDE DOOR HANDLES: The firebox doors allows you to load wood into your stove; a wood handle operates the door. To open the door, rotate handle clockwise and swing the door away from the stove. To latch the door, push the door tightly towards the firebox then rotate handle counterclockwise until it latches shut. Gently pull on the door handle to make sure it is properly latched.

ASH PAN: (This becomes hot during operation. It is best to remove the ash pan only after the stove cools). To access the ash pan you must open the ash door. Grip the ash door handle from the bottom (See figure 11) and rotate toward you. While holding it in the

rotated position pull the handle away from the stove and lower it. When the handle stops lowering allow it to hang by letting go of it. The ash pan handle and the ash grate handle (see figure 12) are now accessible. To remove the ash pan, grip the handle, and then pull it out. The ash pan collects the ash residue from each fire and when full, allows you to remove the ash conveniently from the stove. Clear the firebox of ashes periodically. With the ash pan in position and no fuel other than dead coals in the stove pull the ash grate handle toward you. Sift the ashes through the grate in the bottom of the firebox into the ash pan or shake the ashes into the pan by repeatedly moving the ash grate in and out.



PRIMARY AIR CONTROL: The primary air control lever is located under the ash lip. The primary air control allows you to regulate the amount of air entering the firebox. Generally, the more air allowed into the firebox, the faster the rate of burn and the higher the heat output; conversely, less air creates a slower burn, with lower heat output. For maximum airflow, move the lever left as far as possible; move the lever right as far as possible for minimum airflow (does not close completely). Small adjustments in the low range make a big difference.



Figure 11 – Air Control

BYPASS HANDLE: The bypass handle controls the bypass door inside the stove. When the handle is pointed towards the back of the stove, the bypass door is open, and when the handle is pointed towards the front of the stove, the bypass door is closed. The bypass door directs the flow of combustion products through or around the catalytic combustor. When the

bypass handle is open, combustion products are directed around the catalytic combustor. The bypass handle should be open when first starting a fire until the catalytic combustor heats up to activation temperature, and whenever opening the front door to load the stove. When the bypass handle is closed, combustion products are directed through the catalytic combustor. The bypass handle should be closed once the catalytic combustor heats up to activation temperature, and remain closed whenever the stove is burning and in the active temperature range.

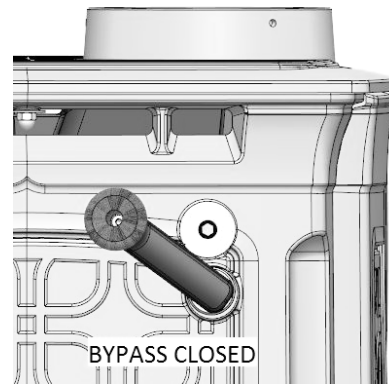

Figure 12 – Closed

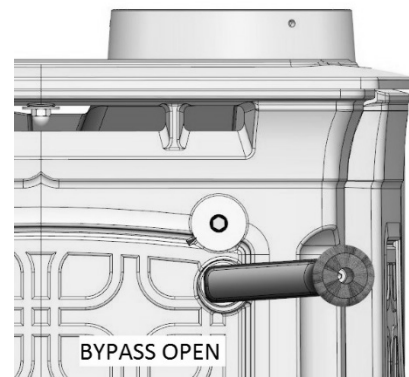

Figure 13 – Bypass Open

CATALYS THERMOMETER: The catalyst thermometer monitors the downstream temperature of the catalysts, and indicates when the stove is in the active range for the catalysts. When the stove is in the “active” range, the bypass handle should be closed. When the stove is in the “Inactive” range, the bypass handle should be opened until the stove heats up. If the thermometer is in the “Too Hot” range, keep the door closed, fully close the air control, and allow the stove to cool down until the thermometer falls into the “Active” Range. Once the catalyst thermometer

has reached the active range, heat generated from burning smoke keeps the catalysts warm and active as long as fuel remains in the stove. The Manchester 8362 typically operates in the 800 °F to 1300 °F range.



Figure 14 – Catalyst Thermometer

higher the BTU content, the longer the burn. Firewood with higher BTUs is generally ideal for a wood stove.

Burn untreated wood only. Other materials such as wood preservatives, metal foils, coal, plastic, garbage, sulfur, or oil may damage the catalysts.

Wood Heat Value: Sorted By Btu Content		
Common Name	Lb/ cord	MBTU/ cord
High		
Osage Orange (Hedge)	4,728	32.9
Hickory, Shagbark	4,327	27.7
Hop Hornbeam (Ironwood)	4,267	27.3
Beech, Blue (Ironwood)	3,890	26.8
Birch, Black	3,890	26.8
Locust, Black	3,890	26.8
Hickory, Bitternut	3,832	26.7
Locust, Honey	3,832	26.7
Apple	4,100	26.5
Mulberry	3,712	25.8
Oak, White	4,012	25.7
Medium High		
Beech, European	3,757	24
Maple, Sugar	3,757	24
Oak, Red	3,757	24
Ash, White	3,689	23.6
Birch, Yellow	3,689	23.6

CHOOSING FIREWOOD

Burn only natural firewood (known as cordwood) in the Manchester Model 8362 Wood Heater. This stove is not designed to burn other fuels.

- **CAUTION: DO NOT USE CHEMICALS OR FLAMMABLE FLUIDS TO START THE FIRE. DO NOT USE CHARCOAL, PELLETS, COAL, ARTIFICIAL LOGS OR ANY OTHER MATERIALS AS FUEL; THEY ARE NOT SAFE. DO NOT BURN GARBAGE OR FLAMMABLE FLUIDS.**
- **THE USE OF UNAUTHORIZED FUEL SUCH AS COAL COULD PRODUCE HIGH LEVELS OF CARBON DIOXIDE IN THE LIVING SPACE. AT HIGH LEVELS CARBON DIOXIDE COULD RESULT IN PERSONAL INJURY OR DEATH.**

The quality of your firewood directly affects heat output, duration of burn and performance of your stove. Softwoods generally burn hotter and faster, while hardwoods burn longer and produce better coals. Density and moisture content are two critical factors to consider when purchasing wood.

The following is a list of some wood species and their relative BTU (British Thermal Unit) content. The

Medium		
Juniper, Rocky Mtn	3,150	21.8
Elm, Red	3,112	21.6
Coffee tree, Kentucky	3,112	21.6
Hackberry	3,247	20.8
Tamarack	3,247	20.8
Birch, Gray	3,179	20.3
Birch, White (Paper)	3,179	20.3
Walnut, Black	3,192	20.2
Cherry	3,120	20
Ash, Green	2,880	19.9
Cherry, Black	2,880	19.9
Elm, American	3,052	19.5
Elm, White	3,052	19.5
Sycamore	2,808	19.5
Ash, Black	2,992	19.1
Maple, Red	2,924	18.7
Fir, Douglas	2,900	18.1

Medium Low		
Boxelder	2,797	17.9
Alder, Red	2,710	17.2
Pine, Jack	2,669	17.1
Pine, Norway (Red Pine)	2,669	17.1
Pine, Pitch	2,669	17.1
Catalpa	2,360	16.4
Hemlock	2,482	15.9
Spruce, Black	2,482	15.9
Pine, Ponderosa	2,380	15.2
Low		
Aspen, American	2,290	14.7
Butternut (Walnut, White)	2,100	14.5
Spruce	2,100	14.5
Willow	2,100	14.5
Fir, Balsam	2,236	14.3
Pine, White (Eastern, Western)	2,236	14.3
Fir, Concolor (White)	2,104	14.1
Basswood (Linden)	2,108	13.8
Buckeye, Ohio	1,984	13.8
Cottonwood	2,108	13.5
Cedar, White	1,913	12.2

Moisture content also plays a key role in the performance of your stove. Wood freshly cut from a living tree (green wood) contains a great deal of moisture. As you might expect, green wood burns poorly. You must season green wood before using it in your wood stove. To season green wood properly, split, stack, and allow it to air dry for a period of one year. Green wood may provide less than 2000 Btu per pound, whereas dry wood can provide up to 7000 Btu per pound.

Stack the firewood on skids or blocks to keep it off the ground, cover only the top of the stack. Plastic or tarps that cover the sides of the woodpile trap moisture and prevent the wood from drying. As for stacking, an old Vermonter said, "The spaces between the logs should be large enough for a mouse to get through, but not for the cat that's chasing it."

- **CAUTION: DO NOT STORE FIREWOOD WITHIN THE STOVE'S SPECIFIED CLEARANCES TO COMBUSTIBLE MATERIALS.**

BUILDING A FIRE

Once you understand the controls of your wood stove and have the appropriate firewood, you are ready to start a fire.

- **WARNING: NEVER USE GASOLINE, GASOLINE-TYPE LANTERN FUEL, KEROSENE, CHARCOAL LIGHTER FLUID, OR SIMILAR LIQUIDS TO START OR 'FRESHEN UP' A FIRE IN THIS HEATER. KEEP ALL SUCH LIQUIDS WELL AWAY FROM THE HEATER WHILE IT IS IN USE.**

BREAKING IN YOUR WOOD STOVE

It is imperative that your stove is "broken in" gradually. Soapstone must be "seasoned"; over-firing a new stove may cause soapstone to crack or may damage other stove parts. Natural moisture in the freshly quarried soapstone must be driven out slowly to minimize the "shock" to the stone of its first exposure to high firebox temperatures. In addition, the asbestos-free furnace cement must be cured slowly to ensure adequate sealing and bonding.

When you light your first fires, the woodstove will emit some smoke and fumes. This is normal "off-gassing" of the paints and oils used when manufacturing the woodstove. If you find it necessary, open a few windows to vent your room. The smoke and fumes will usually subside after 10 to 20 minutes of operation. The odor and smoke will end once the stove is "cured".

The first few fires of the season may produce other odors from impurities that exist in the area immediately surrounding the stove. Some potential impurities are cleaning solvents, paint solvents, cigarette smoke, and soot from scented candles, pet hair, dust, adhesives, a new carpet, and new textiles. These odors will dissipate over time. You can alleviate these odors by opening a few windows or otherwise creating additional ventilation around your stove. If any odor persists, contact your dealer or an authorized service technician.

If you adhere to the operating procedures in this manual, the steel, cast iron, and soapstone components of your stove will give you many years of trouble-free use. With use, the color of the soapstone may change and small fractures may appear on the surface. These changes do not affect the function of the stove. If a panel breaks completely, it must be replaced.

Avoid the following conditions that can cause the glass, soapstone, steel or cast iron pieces to break:

- Do not throw wood into the stove.
- Do not use the door as a lever to force wood into the stove.
- Do not load wood encrusted with ice into a burning stove - the thermal shock can cause damage.

- Do not use a manufactured log grate or otherwise support the fuel. Burn the fire directly on the floor of the firebox.

BUILDING A BREAK IN FIRE

- 1) Open the bypass handle. Open the front or side door and place five or six double sheets of tightly twisted newspaper in the center of the firebox. Arrange kindling in a crisscross pattern over the newspaper. Kindling should be approximately ten pieces, 1/2" (13 mm) in diameter and 10" to 16" (254 mm to 457 mm) long.
- 2) Fully open the primary air control by moving the control handle to the left.
- 3) Light the paper under the kindling. Leave the door slightly ajar momentarily until the kindling has started to burn and draft begins to pull (**never open ash door to establish draft**).
- 4) Close the door and allow the fire to burn. Keep the door closed while the stove is in use.
- 5) KEEP A WATCHFUL EYE ON YOUR STOVE to maintain a steady, low-heat fire. Your first fire should make the stove warm but **not hot to the touch**. Visible steam, or boiling moisture and hissing indicate the soapstone is too hot. At most, a few small chunks of wood should be added to the fire to reach safe break-in temperatures.
- 6) Once the stove is warm but **not hot to the touch**, close the primary air control by pushing it fully inward toward the stove to allow the fire to die out completely.
- 7) Let the stove return to room temperature.

Your first fire and first fire each season thereafter should be built and maintained as outlined above. Your patience will be rewarded by a properly seasoned stove.

- NOTE: The cool flue gas temperatures present during the break-in procedure may cause rapid creosote build-up. The door glass may also get dirty. A good hot fire will clean it. We recommend a visual inspection (and cleaning if necessary) of your stovepipe and chimney once the break-in procedure is completed.

NORMAL OPERATION

BUILDING A FIRE FOR EVERYDAY USE

- 1) Open the bypass handle. Open the front or side door and place five or six double sheets of tightly twisted newspaper in the center of the firebox.

Arrange kindling in a tee-pee configuration over the newspaper. Use approximately 10 pieces of kindling, 1/2" (13 mm) in diameter and 10" to 16" (254 mm to 406 mm) long.

- 2) Fully open the primary air control by moving the lever completely to the left.
 - 3) Light the paper under the kindling. Leave the front door slightly ajar momentarily until the kindling begins to burn and draft begins to pull (**never open ash door to establish draft**).
 - 4) Close the door and allow the fire to burn.
 - 5) Once the kindling is burning, open the front or side door and add logs, small at first, to build the fire up. Ensure you keep the logs away from the glass in front in order for the air-wash system to work properly. Keep the doors closed while the stove is in use.
- CAUTION: DO NOT BUILD THE FIRE TOO CLOSE TO THE GLASS. KEEPING THE FIRE TOWARDS THE CENTER OF THE FIRE BOX WILL KEEP COALS FROM BUILDING UP AGAINST THE GLASS DURING RELOADING.**
- 6) Once the fire is burning well, and the catalyst thermometer indicates that the stove is in the active range, close the bypass handle. Now the combustion products are passing through the catalytic combustor, and your stove will be burning at its optimal efficiency.
 - 7) After closing the bypass door, allow the stove to run on a high setting for around 20 minutes to ensure the catalytic combustor stays in the active range. This will also allow the fire to burn off any residue on the door glass from any previous low-burn fires
 - 8) Use the primary air control to regulate the desired rate of burn. Move the handle left for a higher burn rate, and move the handle towards the right for a lower burn rate. The air control does not close completely.

Note: Always remember to open the bypass handle before opening the front door. When opening the front door to reload or re-arrange logs, it is advisable to open the door just a crack, pause for a moment then open the door completely. This procedure allows the firebox to clear of smoke before the door is open fully. In addition, reloading on a bed of hot, red coals reduces smoking time and brings fresh fuel up to a high temperature rapidly. During the refueling and rekindling of a cool fire, or a fire that has burned down to the charcoal phase, operate the stove at a medium to high firing rate for about 10 minutes to ensure that the catalysts reach approximately 600 °F. Once the

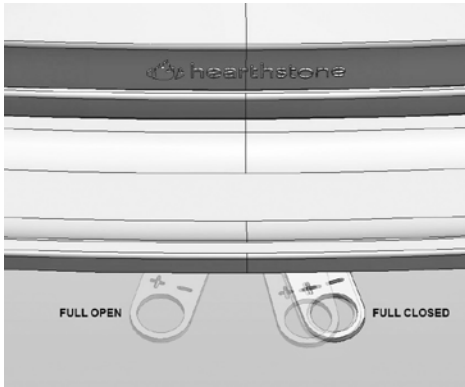

Figure 15 – Air Control Position

catalysts reach operating temperature, the bypass handle can be closed. When reloading the stove, try to keep an open path behind the Lower Primary Air Opening (LPAO). It is helpful to leave a small valley in the coal bed behind the LPAO to insure faster re-lighting.

CATALYTIC COMBUSTOR OPERATION

The Manchester 8362 uses a catalytic combustor to ensure highly clean and efficient burns. The catalytic combustor is made from a stainless steel corrugation that is coated with a catalytic material. The catalytic combustor becomes active around 500 °F (260°C), helping to burn up smoke and any remaining particles that were not fully burned in the firebox. During the startup of a cold stove, a medium to high firing rate must be maintained for about 20 minutes. This ensures that the stove, catalysts, and fuel are all stabilized and at proper operating temperatures. Even though it is possible to have gas temperatures reach 500 °F (260°C) within 2 to 3 minutes after a fire is started, if the fire is allowed to die down immediately, it may go out or the combustor may stop working. Once the stove and catalytic combustor heat up, heat generated from burning smoke keeps the catalysts warm and active as long as fuel remains in the stove. You stove will burn the cleanest and most efficiently when the catalysts are in the active range. There should be little to no visible smoke from your chimney when the catalysts are in the active zone and fully functional.

BURN RATE

This wood heater has a manufacturer-set minimum low burn rate that must not be altered. It is against federal regulations to alter this setting or otherwise operate this wood heater in

a manner inconsistent with operating instructions in this manual

LOW BURN: Move the air control lever all the way toward the right. (See figure 15). This closes the air shutter to its minimum opening. A low burn rate over extended periods is not advisable as it can promote the accumulation of creosote. Inspect the venting system frequently if using low burn rates consistently.

MEDIUM LOW BURN: With the primary air control in the low position, push the air control left (a little less than 1/16"). A medium-low burn rate is the typical setting and is preferable if the stove is unattended. At this burn rate, a little goes a long way.

MEDIUM HIGH BURN: With the primary air control in the low position, move the air control left (about 3/8")

HIGH BURN: Completely open the primary air control by moving it all the to the left. Fully load the firebox with wood on a bed of hot coals or on an actively flaming fire. To minimize creosote accumulation, run the stove on high once or twice daily for 35 to 45 minutes to fully heat the stovepipe and chimney.

CAUTION: Do not burn fuel other than cordwood in your stove.

OVER-FIRE CAUTION

Over-firing means the stove is operating at temperatures above normal temperatures reached during High Burns outlined in the *BURN RATE* section. Carefully avoid over-firing, as it will damage the stove. Symptoms of chronic over-firing can include warped components, short burn times, a roaring sound in the stove or stovepipe, and discoloration of the stovepipe. A properly installed stove using fuel and following operating procedures as outlined in this manual should not over-fire.

Excessive draft, inappropriate fuel, and operator error can cause over-firing. Correct an over-fire situation as follows:

- **EXCESSIVE DRAFT:** Contact your local dealer to have a draft reading taken. Any draft in excess of 0.1 WC requires a damper in the stovepipe. Some installations may require more than one damper.
- **INAPPROPRIATE FUEL:** Do not burn coal; kiln dried lumber, wax logs, compressed wood, highly volatile fuels or combustibles, or anything other than natural cordwood.
- **OPERATOR ERROR:** Ensure all the gaskets are in good condition. Replace worn out or

compressed gaskets. Only burn the stove with the firing and ash doors in the closed position.

If you suspect your stove is over-firing, discontinue use and contact your dealer immediately. **Damage caused by over-firing is not covered by your warranty.** Results of over-firing can include warped or burned out internal parts, cracked refractory panels, discolored or warped external parts, and damaged finish.

- **ANY SIGNS OF OVER-FIRING WILL VOID YOUR WARRANTY!**
- **ALL DOORS MUST REMAIN CLOSED WHEN IN OPERATION**

REMOVAL AND DISPOSAL OF ASHES

You can leave a thin layer of ashes in the firebox if preferred. Allow fire to die down or go out completely. It is important to prevent ashes from building up around the door openings or they will spill out, or they can pack into the gasket channel and prevent proper sealing. To remove ashes, use a fireplace shovel. Avoid removing large live coals by pushing them to the side and removing only the finer ash with a shovel.

Disposal of ashes - Ashes should be placed directly into a **metal** container with a tight-fitting lid. Do not place any other items or trash into the metal container. Do not pour water into the container. Replace the container's lid and allow the ashes to cool. Never place the ash disposal container on a combustible surface or vinyl flooring, as the container could be **hot!**

Pending disposal, place the closed ash container on a noncombustible floor or on the ground outside, well away from all combustible materials, liquid fuels, or vehicles. Retain ashes in the closed container until all coals thoroughly cool.

If the ashes are disposed of by burial in soil or otherwise locally dispersed, they should be retained in the closed container until all cinders have thoroughly cooled.

NEVER place ashes in wooden or plastic containers, in trashcans with other trash, or in paper or plastic bags, no matter how long the fire has been out. Coals within a bed of ashes can remain hot for several days once removed from the firebox.

MAINTENANCE

CATALYTIC COMBUSTOR INSPECTION AND REPLACEMENT PROCEDURES

- **WARNING: THIS WOOD HEATER CONTAINS A CATALYTIC COMBUSTOR, WHICH NEEDS PERIODIC INSPECTION AND REPLACEMENT FOR PROPER OPERATION. IT IS AGAINST FEDERAL REGULATIONS TO OPERATE THIS WOOD HEATER IN A MANNER INCONSISTENT WITH OPERATING INSTRUCTIONS IN THIS MANUAL, OR IF THE CATALYTIC ELEMENT IS DEACTIVATED OR REMOVED**

It is important to periodically monitor the operation of the catalytic combustor to ensure that it is functioning properly and to determine when it needs to be replaced. A non-functioning combustor will result in a loss of heating efficiency, and an increase in creosote and emissions. Following is a list of items that should be checked on a periodic basis.

-Combustors should be visually inspected at least three times during the heating season to determine if physical degradation has occurred. Actual removal of the combustor is not recommended unless more detailed inspection is warranted because of decreased performance. If any of these conditions exists, refer to Catalyst Troubleshooting section of this owner's manual.

-This catalytic (or hybrid) heater is equipped with a thermometer to monitor catalyst operation. Properly functioning combustors typically maintain temperatures in excess of 500 °F, and often reach temperatures in excess of 1,000 °F. If catalyst temperatures are not in excess of 500 °F, refer to the Catalyst Troubleshooting section of this owner's manual.

-You can get an indication of whether the catalysts are working by comparing the amount of smoke leaving the chimney when the smoke is going through the combustor and catalysts light-off has been achieved, to the amount of smoke leaving the chimney when the smoke is not routed through the combustor (bypass mode).

1. Light stove in accordance with operator's instructions
2. With smoke routed through the catalysts, go outside and observe the emissions leaving the chimney.
3. Engage the bypass mechanism and again observe the emissions leaving the chimney. Significantly more smoke will be seen when the exhaust is not routed through the combustor (bypass mode)

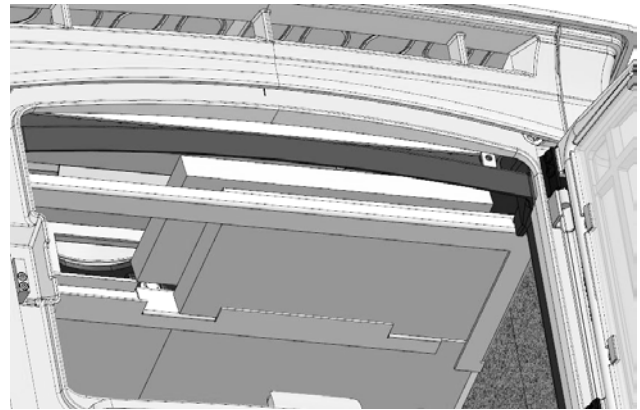
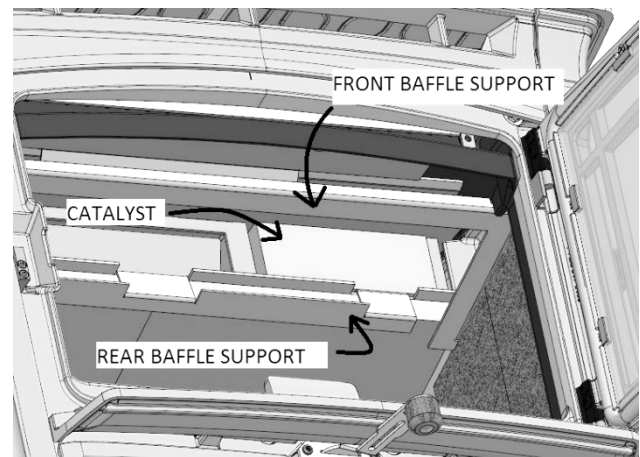

Figure 16 - Removing/Replacing the Front Baffle for Inspection

1. Allow the stove and ashes to fully cool.
2. Lift one of the front baffle segments from the front by pushing up and pulling towards front. Place it on top of the other.
3. Lift both baffle segments together and, angle them slightly front to back and pass them down and out of the stove.
4. **CAUTION - Do not force the baffle pieces. Gently adjust the baffle orientation until they can be removed freely from the stove.**
5. Reverse process to install and make sure to close gap between baffle segments.

INSPECTING THE CATALYSTS AND REMOVING/REPLACING THE BAFFLE



1. Examine the catalysts to make sure they are in the correct position (if they look crooked push them gently to reseat them).
2. Use a flashlight to check for ash buildup on the face of the combustors.

3. Use a small vacuum nozzle or soft bristled brush to remove any accumulated ash or soot on the face of the catalyst.
4. **Do not vacuum or brush the blanket surrounding the combustor.**
5. Inspect the catalyst for any unusual warping, corrosion, or plugged openings.
6. If any unusual conditions are found, remove the catalyst blocks – See replacing the catalysts.

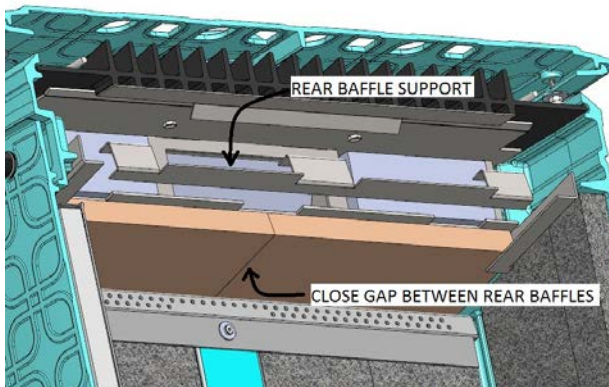
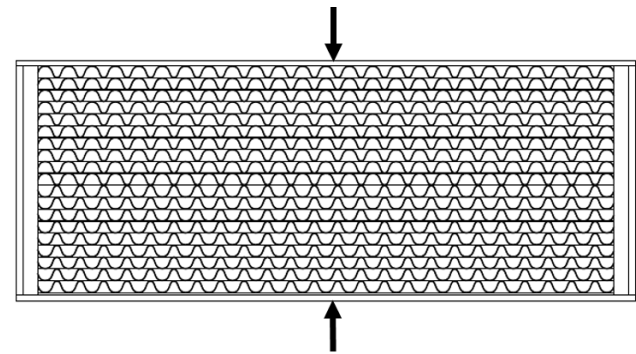

Figure 17 - Removing/Replacing the Rear Baffle for Inspection

1. With front baffle segments removed lift front baffle support at front edge and pull toward front of stove.
2. With back end clear, lower baffle support into fire box and remove from stove.
3. While holding up rear baffles with one hand pull rear baffle support toward front and set aside.
4. Lower rear baffle segments and pull to remove.
5. Reverse procedure to replace, being sure to keep baffle segments tight together.

REMOVING OR REPLACING THE CATALYSTS

Refer to the Catalytic combustor warranty on page 35

Figure 18 (cont.) - Removing/Replacing the Baffle for Inspection

for catalyst replacement information. **DO NOT OPERATE UNIT WITHOUT CATALYSTS.** Only remove the catalysts if required. In general, the less you handle the catalysts, the better. If any unusual conditions are found, remove the catalyst blocks

1. Allow the stove and ashes to fully cool.
2. Follow the procedures from "INSPECTING THE CATALYSTS AND REMOVING/REPLACING THE FRONT BAFFLE" to gain access to the catalysts.
3. Inspect the catalysts for visible damage or fly ash. If fly ash exists, gently brush the catalyst off with a

narrow soft-bristle brush, or vacuum with a crevice tool.

4. If excessive fly ash exists, or if there is suspected catalyst performance issues, fully remove the catalysts by gently pulling the catalysts outwards towards the front of the stove. It may be necessary to gently rock the catalysts from side to side and top to bottom while pulling outwards to free the catalysts from the opening. **Avoid dragging catalyst over bolts.**
5. If fly ash exists, or if there are suspected catalyst performance issues, fully remove the catalysts by gently pulling upwards from the ribs in the cast iron, and then pulling outwards through the catalyst access opening.
6. Remove any remaining gasket material from the opening and from the catalysts.
7. Inspect the catalysts for any fly ash or clogging, and remove with a soft bristled brush or vacuum crevice tool. If extra cleaning is needed, follow the guidelines below:
 - You may use compressed air under 35 psi, air only, no chemicals.
 - You may soak the catalysts in a hot water mix (not boiling), 4 parts water, 1 part vinegar. Rinse with cold water until vinegar smell is mostly gone.
 - No metal tools such as gun cleaners should be used.

-No detergents or chemicals.

Figure 20 - Acceptable Cataly

8. Some warping or bowing of the catalysts over time is acceptable, as long as the catalyst gasket

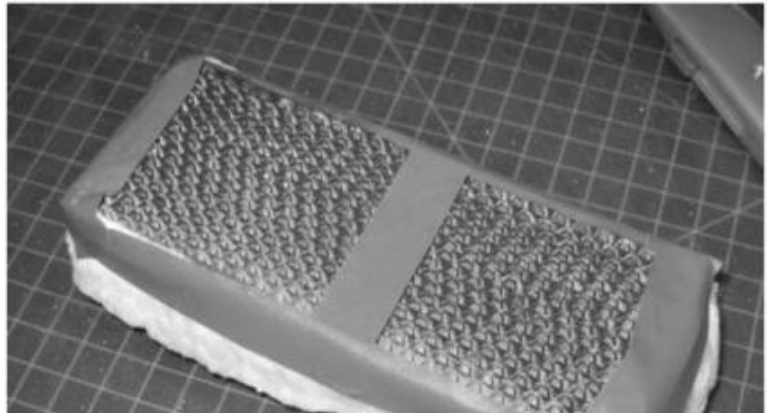
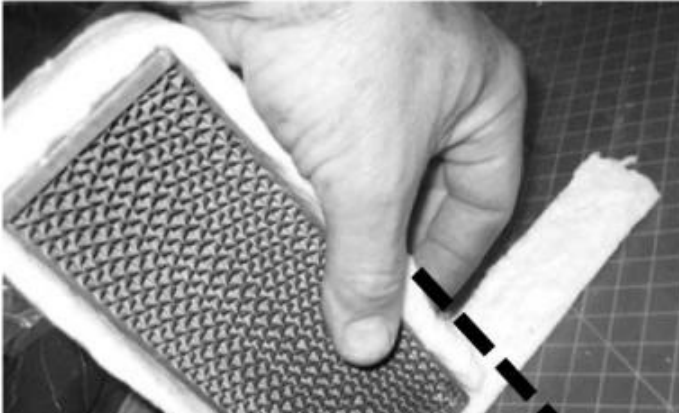

continues to seal. Measure the catalysts in the middle section – if the dimensions are outside the range shown in Figure 20 on the next page, replace the catalysts.

9. Only remove the catalysts if required. In general, the less you handle the catalysts, the better. If any unusual conditions are found, remove the catalyst blocks – See replacing the catalysts.
 9. Some warping or bowing of the catalysts over time is acceptable, as long as the catalyst gasket continues to seal. Measure the catalyst in the middle section – if the dimensions are outside the range shown in Figure 21 above, replace the catalyst.
 10. Re-install ceramic wool gasket material on the catalysts. Keep the gasket material flush with one side of the catalyst. Masking tape can be used to hold the gasket in place on the catalyst. It will burn away when the stove gets hot. Wrap the tape around the gasket and catalyst so it is reasonably tight and some of the tape side is hanging over the edge of the catalyst, all around. Fold the edges of the tape in over the catalyst face. Finally add 3 smaller strips of tape as shown
11. Once the gasket is installed on the catalysts, gently push the catalyst into the catalyst opening until the catalyst hits against the back wall of the cavity. Take care to ensure the gasket is not damaged.

GLASS REPLACEMENT PROCEDURES

WARNING: DO NOT OPERATE THIS APPLIANCE WITH THE GLASS PANEL REMOVED, CRACKED, OR BROKEN. DO NOT SUBJECT THE DOOR TO ABUSE, SUCH AS STRIKING OR SLAMMING SHUT. ONLY A QUALIFIED SERVICE PERSON SHOULD REPLACE THE GLASS PANEL.

1. Follow the instructions included with the replacement glass kit.
2. Remove the door.
3. Remove the screws from the glass retainer (use penetrating oil if necessary) – lift the retainer off the glass. Set aside for reinstallation.
4. Carefully lift the damaged glass out of the door and discard.
5. Remove any remaining glass and old gasket material.
6. Clean the screw holes and place a small amount of anti-seize compound in each one.

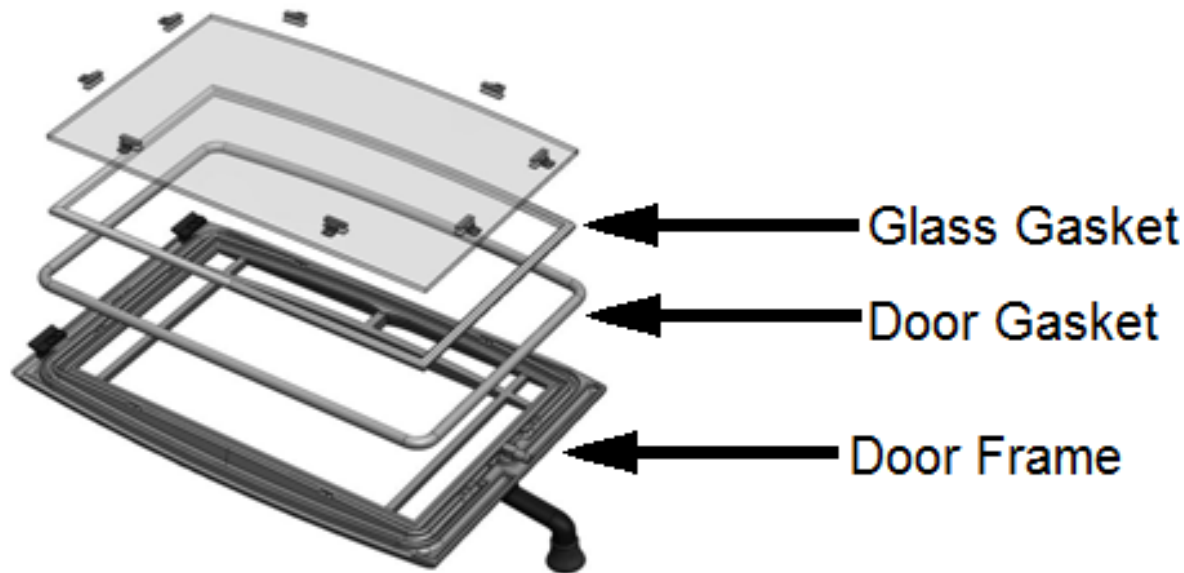

7. Place the gasketed new glass onto the door. **Ensure sticker is on the exterior face of the glass.**
8. **Important! Center the glass** and ensure that the edges of the glass are parallel with the edges of the opening.
9. Check glass position again (centered, and parallel), then screw the glass retainer clips back on the door using a crisscross pattern. Tighten the screws no more than 1/8th of a turn after they seat. The glass will break at this point if not positioned correctly.
10. Apply a light film of anti-seize lubricant on the door's hinge pins if needed.
11. Install the door.
12. After 5 or 6 fires, check the glass retainer screws, and retighten if necessary.

Required Glass Kit: Part Number: 90-58901 (Glass with gasket applied). Use only 5mm Ceramic IR, or Neoceram IR glass. Contact your Hearthstone dealer.

CREOSOTE FORMATION & REMOVAL

When wood burns slowly at low temperatures, it may produce tar and other organic vapors, which combine with expelled moisture to form creosote. These creosote vapors condense in the relatively cool chimney flue of a slow-burning fire. As a result, creosote residue accumulates on the flue lining. When ignited, this creosote makes an extremely hot fire, which may damage the chimney or even destroy the house. When burning wood, inspect the chimney connector and chimney at least once every two months

during the heating season to determine if there is a creosote buildup.

If a creosote build-up occurs, inspect the stovepipe connector and chimney more often, at least monthly during the heating season to monitor the accumulation. If a creosote residue greater than 1/4" (6 mm) accumulates, remove it to reduce the risk of a chimney fire.

Prevention

Burn the stove with the primary air control fully open for 35 - 45 minutes daily to burn out creosote deposits from within the stove and the venting system.

After reloading with wood, burn the stove with the primary air control fully open for 15 to 20 minutes. This manner of operation ensures early engagement of the secondary combustion system that minimizes creosote buildup in the chimney.

If your glass always remains dirty, your operating temperatures are too low or your wood is wet; therefore, there is a higher risk of creosote buildup.

Inspect the venting system at the stove connection *and* at the chimney top. Cooler surfaces tend to build creosote deposits faster, so it is important to check the chimney at the top (where it is coolest) as well as from the bottom near the stove.

Cleaning

Remove accumulated creosote with a cleaning brush specifically designed for the type of chimney in use. We recommend you use a certified chimney sweep to perform this service. Contact your dealer

for the name of a certified chimney sweep in your area (your dealer may be a certified sweep!).

We recommend that before each heating season you have the entire system professionally inspected, cleaned and repaired, if necessary.

GASKETS

Replace door gasket material every two to three seasons, or whenever it becomes deteriorated or loose, depending on stove use. If the door seal leaks, a new gasket will ensure a tight seal and improve stove performance.

We recommend you only use Hearthstone replacement gaskets when you need to replace your door gasket. Contact your dealer for a gasket kit that includes instructions, and the gasket for your stove.

GLASS

The glass used in our stoves is actually not plain glass, but a tough, clear ceramic material capable of operating at temperatures up to 2300° F. Do not operate the stove with a broken door glass. Do not abuse the front door by striking or slamming.

When necessary, clean the glass. We recommend using a damp paper towel dipped in gray ash. Rub the inside of the glass with a circular motion. When all the deposits are removed, clean up with window cleaner or with commercial stove glass cleaners, which are available from your local dealer. Never attempt to clean the glass while the fire is burning or while the glass is hot. Remove deposits by following the instructions provided with the cleaner. Wipe the cleaner off with a soft cloth, or black & white newsprint.

Important: scratching or etching the glass will weaken the integrity of the glass. Do not use a razor blade, steel wool, or any other abrasive material to clean the glass. Use a cleaner specifically manufactured for woodstoves only.

The front door glass is a ceramic, thermal shock-resistant glass, made specifically for use in woodstoves. Do not use any replacement glass other than the ceramic glass manufactured and supplied for use in this woodstove. Replacement glass is available through your local dealer.

Replace the door glass immediately if broken or chipped. Contact your local dealer for replacement

glass. The glass kit includes instructions and everything needed for the repair. If you replace the

PREVENTION

Burn the stove with the primary air control fully open for 35 - 45 minutes daily to burn out creosote deposits from within the stove and the venting system.

After reloading with wood, burn the stove with the primary air control fully open for 15 to 20 minutes. This manner of operation ensures early engagement of the secondary combustion system that minimizes creosote buildup in the chimney.

If your glass always remains dirty, your operating temperatures are too low or your wood is wet; therefore, there is a higher risk of creosote buildup.

Inspect the venting system at the stove connection *and* at the chimney top. Cooler surfaces tend to build creosote deposits faster, so it is important to check the chimney at the top (where it is coolest) as well as from the bottom near the stove.

CLEANING

Remove accumulated creosote with a cleaning brush specifically designed for the type of chimney in use. We recommend you use a certified chimney sweep to perform this service. Contact your dealer for the name of a certified chimney sweep in your area (your dealer may be a certified sweep!).

We recommend that before each heating season you have the entire system professionally inspected, cleaned and repaired, if necessary.

TROUBLESHOOTING

COMMON ISSUES

Virtually all woodstove operators experience basic common problems at one time or another. Most are correctable and generally require only a minor adjustment of the stove, installation, or operating technique. In cases where weather conditions dramatically affect stove performance, the problems are typically temporary and solve themselves once the weather changes.

If you question whether your stove is producing adequate heat, the best way to troubleshoot the problem is to monitor the temperature of the stack no more than 12 inches (30 cm) above the flue collar. A 400° F (200° C) stovepipe confirms the stove is supplying sufficient heat. Keep in mind that your house itself will regulate room/house temperatures. How well the walls, floors and ceilings are insulated, the number and size of windows, the tightness of outside doors, and the construction or style of your house (vaulted ceilings or other open spaces which collect large percentages of heat, ceiling fans, etc.) all are determining factors of room temperature.

Your stove's performance is also dependent on its installation. One common cause of poor performance is an oversized chimney flue. Oversized chimney flues result in decreased draft, which prevents the smoke from rising out the chimney. Oversized flues are also more difficult to heat effectively, especially when burning a high efficiency stove. Cool flue temperatures inhibit the establishment of a strong draft (and encourage the accumulation of creosote). The lack of a strong draft will cause the fire to die down and may even force smoke to pour into the room.

If your chimney is the proper size and a strong draft is not easily established, there is the possibility that the chimney is too cold. Again, hot chimneys promote stronger drafts. Opening a window briefly in the room while lighting the stove may help.

Other draft guidelines are as follows:

An **"AIRTIGHT" HOUSE:** The air supply (infiltration) to the interior of the house may be inadequate if your home is super-insulated or especially well sealed. This phenomenon of air starvation within the

building is exacerbated if exhaust fans, such as clothes dryers, bathroom fans or cook stove exhaust fans, are in operation within the home. Outfitting your stove with the optional outside air adaptor connected to an air duct, which leads to the outside of the building, can correct this problem.

Tall Trees or Buildings: These obstructions, when located close to the top of the chimney can cause chronic or occasional downdrafts. When selecting a site for a new chimney, consider the placement of other objects near the proposed chimney location.

Wind Velocity: Generally, the stronger and steadier a wind, the stronger (better) the draft. However, "gusty" wind conditions can cause erratic downdrafts. For consistent problems, consider a high wind cap, such as the Vacu-Stack.

Barometric Pressure: Chimney drafts are typically sluggish on balmy, wet or muggy days (low barometric pressure). This is a weather-related phenomenon, which generally is self-correcting as the weather changes.

Briskness of Fire: The hotter the fire in your stove, the hotter your chimney and, therefore, the stronger the draft.

Breaks in the Venting System: An unsealed clean-out door at the bottom of the chimney, leaky stovepipe joints, a poor stovepipe-to-thimble connection, missing caps, or a leaky chimney all can cause inadequate draft.

Seasonal Factors: Early fall and late spring are generally difficult seasons in which to establish proper drafts. The colder the outside air is relative to room temperature, the stronger the draft.

OPERATING THE STOVE

As outlined above, there are days when a good draft is just not easy to establish. The causes are usually seasonal factors or a cold chimney. Try starting the fire by using small kindling and fuel to obtain a quick, hot fire. Tend the fire frequently with small fuel until the chimney is hot and the draft is well established. Sometimes, partially opening a first floor window briefly will help quickly get draft established.

TROUBLESHOOTING GUIDE

PROBLEM	POSSIBLE CAUSE	SOLUTIONS
STOVE SMOKES	Operating Technique	Fully open the primary air control one minute before opening doors, and ensure the bypass is open before opening door.
	Cold Chimney or reverse draft	Preheat the chimney when first starting a fire. Briefly open a window in the room containing the stove.
	Blocked Chimney	Examine the chimney and stovepipe for blockage or creosote accumulations.
	Oversized Chimney	Reline the chimney to the appropriate diameter
	Undersized Chimney	Install a draft inducer or replace the chimney.
	Chimney Too Short	Lengthen the chimney.
	Air Infiltration Into The Chimney	Seal chimney connections and openings. Check clean-out doors.
	Bypass not closed	Ensure that the bypass door is closed when the catalysts are in the active range.
	Catalysts not functioning	Inspect catalysts for damage, ash build-up, or plugging. Brush catalysts with a soft-bristled brush, or vacuum lightly. Replace if required. Follow instructions to ensure catalyst light-off.
	Not burning proper fuel	Ensure cordwood is seasoned and dry.
More Than One Appliance Connected to the Flue	Disconnect all other appliances and seal openings.	
BACK-PUFFING OR GAS EXPLOSIONS	Operating Technique	Fully open the primary air control one minute before opening the door and keep it fully open for a few minutes after reloading. Ensure the bypass door is open before opening the door
	Extra Low Burn Rate	Burn the stove at a higher burn rate.
	Chimney Down-draft	Install a chimney cap.
	Excessive Ash Build-up	Empty the ash pan more frequently. Increase efficiency of burns, and avoid using poor quality or green wood.
UNCONTROLL- ED OR SHORT BURN	Unsealed or Open Door	Close the door tightly or replace the gaskets. Air leakage around glass gasket – replace gasket
	Excessive Draft	Check the installation. Operate at LOW BURN. Install stovepipe damper. Draft in excess of 0.1 wc should be corrected with a stovepipe damper(s)
	Extra Long Chimney	Shorten the chimney. Install stovepipe damper(s).
	Oversized Chimney	Reline the chimney to the proper diameter.
	High Winds or Hilltop Location:	Install a chimney cap.
INSUFFICIENT HEAT	Poor Quality, low Btu content, or Green Wood	Use only air-dried wood, preferably dried <u>at least</u> one year. Use a wood with a high Btu content if available.
	Low Burn Rate	Operate the stove at a higher burn rate.
	Cold Exterior Chimney	Reline or insulate the chimney.
	Leaky Stovepipe or Chimney	Check the installation. Replace with a pre-fabricated insulated chimney system or a properly sized masonry chimney.
	Too Much Heat Loss From House	Add insulation, use energy efficient windows, or caulk windows, and seal openings in home.
	Excessive Ash Build-up	Empty the ash pan more frequently. Increase efficiency of burns, and avoid using poor quality or green wood.
BLISTERING OF FINISH	Operating Technique	Do not over-fire the stove. Monitor stove temperatures. Use seasoned wood only.
	Excessive Draft	Check the DRAFT. A damper may be required. Operate the stove at a LOW BURN range.

ADDITIONAL CATALYST TROUBLESHOOTING GUIDE

PROBLEM	POSSIBLE CAUSE	SOLUTIONS
FLY ASH BUILD UP ON CATALYSTS	Catalysts have not maintained light-off temperature	Brush cold combustor with soft-bristled brush or vacuum lightly. Follow instructions in the manual for a proper catalyst light-off
	Burning materials that cause a lot of char and fly-ash	Don't burn cardboard, gift wrap paper, or garbage. Burn only dry, seasoned wood, per the owner's manual.
	Bypass closed too soon	Follow instructions in the manual for a proper catalyst light-off
CATALYSTS PLUGGING OR MASKING (SOOT/CRESOTE)	Burning wet, pitchy woods, or burning large loads of small diameter wood with the combustor in the operating position without catalyst light off occurring	Burn dry seasoned wood. Follow instructions in the manual for a proper catalyst light-off, and ensure catalyst light-off as occurred before closing bypass damper. It may be possible to burn the soot or creosote off by building a hot fire, and allowing the stove to run until the catalysts are well within the operating range before closing the bypass. Continue to run the stove at a high temperature for one hour, while ensuring the catalysts stay in the upper operating range, but not too hot.
WARPING OR BOWING OF THE CATALYSTS	Excessive catalyst temperatures for long periods of time.	Ensure that the catalysts remain in the operating zone, and does not get too hot. Reduce air control settings for a lower burn rate to ensure catalyst temperatures do not exceed the operating range.

REPLACEMENT PARTS & OPTIONAL ACCESSORIES

PART #	DESCRIPTION	PART #	DESCRIPTION
	CASTINGS		STEEL SET CONTINUED
2010-282	FLUE PLATE	5362-024	PRIMARY AIR SLIDER MCR1
2010-285	FLUE COLLAR *	5361-030	PUSH ROD
2310-600	PRIMARY AIR PLENUM	5361-035	HOLE COVER FLAP
2310-605	UPPER ASH GRATE	5361-040	HOLD DOWN CLIP
2310-610	TOP PANEL	5491-045	DOOR CATCH
2310-615	FRONT DOOR *	7200-525	CATALYST TEMPERATURE PROBE
2310-617	FRONT/SIDE/BYPASS DOOR HANDLE		
2310-620	SIDE DOOR *		
2310-625	ASH PAN FRAME		
2310-630	INNER REAR PANEL		MISCELLANEOUS
2310-635	BOTTOM	1-0000-101	REFRACTORY STONE (4-1/2"x9")
2310-641	SIDE PANEL* (WITH NO DOOR OPENING)	1-0000-301	REFRACTORY STONE (10-3/4"x5-1/4")
2310-646	SIDE PANEL* (WITH DOOR OPENING)	1-0000-304	REFRACTORY STONE (4-7/8"x12")
2310-650	GRILL *	1-0000-305	REFRACTORY STONE (11-1/2"x4-7/8")
2310-655	ASH PAN DOOR HANDLE *	3070-021	VERMICULITE BAFFLE QUARTER
2310-660	ASH LIP *	3120-362	CERAMIC, SIDE DOOR BOARD
2310-665	LOWER ASH GRATE	3120-035	CERAMIC BLANKET CATALYST
2310-670	SECONDARY AIR PLENUM, BOTTOM	3120-364	CERAMIC REAR STRIP
2310-675	FRONT PLATE	3120-365	CERAMIC SIDE POST CAT
2310-685	TOP *	3050-010	CATALYST
2310-690	REAR PANEL *		
*SPECIFY COLOR IF FINISH IS ENAMELED			
	STEEL SET		
5021-060	GLASS CLIP		OPTIONAL ACCESSORIES
5362-095	FRONT BAFFLE SUPPORT	90-57310	CATALYST REPLACEMENT KIT
5362-090	REAR BAFFLE SUPPORT	93-57600	BLOWER KIT
5360-010	ASH PAN	93-53500	OUTSIDE AIR KIT
5360-012	ASH DOOR	93-68600	CLOSE CLEARANCE HEAT SHIELD KIT
5360-014	ASH DOOR HINGE	93-69600	SPARK SCREEN KIT
5360-028	AIR CONTROL LEVER	93-58300	GLASS KIT
		93-58600	GASKET KIT
5360-050	FRONT DOOR HINGE W/ PIN	93-71600	FRONT & SIDE DOOR HANDLE KIT
5360-052	REFRACTORY RETAINER	94-73910	SIDE DOOR LATCH KIT
5360-058	SIDE DOOR HINGE	93-73600	FRONT DOOR LATCH KIT
5360-060	SIDE DOOR HINGE CLIP	93-70607	SIDE DOOR LOCKING KIT
5360-062	FRONT DOOR HINGE (NO PIN)		
5360-085	TOP HEAT SHIELD		

Refer to the Illustrated Parts list for further detail about stove components, available online at www.hearthstonestoves.com.

SAFETY LABEL

CONTACT YOUR LOCAL BUILDING OFFICIALS ABOUT RESTRICTIONS AND INSTALLATION INSPECTION IN YOUR AREA

Listed Room Heater, Solid Fuel Type
Also Suitable for Mobile Home Installation Pursuant to (UM)84-HUD



Conforms to UL STD 1482
Certified to ULC STD S627

Manufactured by:



317 Stafford Ave.
Morrisville, VT 05661

MODEL NAME:
MANCHESTER
MODEL NUMBER: 8362
SERIAL NUMBER:



CAUTION: HOT WHILE IN OPERATION. DO NOT TOUCH. KEEP CHILDREN, CLOTHING, AND FURNITURE AWAY. CONTACT MAY CAUSE SKIN BURNS. SEE NAMEPLATE AND INSTRUCTIONS. INSPECT AND CLEAN CHIMNEY AND CONNECTOR FREQUENTLY. UNDER CERTAIN CONDITIONS OF USE, CREOSOTE BUILDUP MAY OCCUR RAPIDLY.

WARNING:

Do not use grate or elevate fire. Build wood fire directly on hearth. Do not overfire. If the heater or ohimney onnector glows, you are overfiring. (See Operator's Manual)

OPERATE ONLY WITH DOORS CLOSED. DO NOT OBSTRUCT SPACE UNDER HEATER.
TYPE OF FUEL: CORD WOOD ONLY - BURNING FUELS OTHER THAN CORDWOOD MAY DAMAGE THE APPLIANCE

"PREVENT HOUSE FIRES"

Install and use only in accordance with manufacturer's installation instructions and your local building codes.

CAUTION: Special methods are required when passing ohimney through a wall or ceiling, refer to local building codes. Do not onnect this unit to a ohimney flue serving another appliance.

NOTE: Replace glass only with 5mm ceramic glass.

This wood heater needs periodic inspection and repair for proper operation. Consult the owner's manual for further information. It is against federal regulations to operate this wood heater in a manner inconsistent with the operating instructions in the owner's manual.

WARNING: (Mobile Home) An outside air inlet must be provided for combustion and be unobstructed while the unit is in use.

THIS APPLIANCE USES A CATALYTIC COMBUSTOR (PIN P/N WF-4160001078)
The performance of the catalytic device or its durability has not been evaluated as part of the certification
CAUTION: Burning materials other than the specified fuels may make the catalyst inactive

Minimum Clearance to Combustible Materials*

Floor Protection*

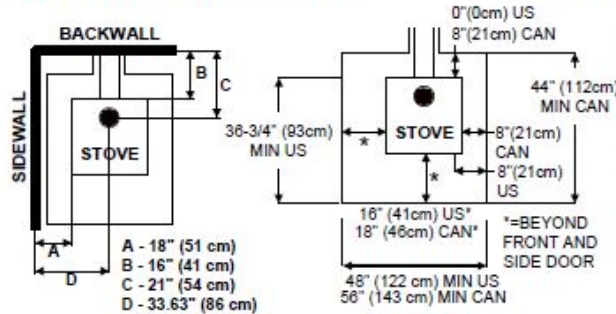

When installed on a combustible floor, non-combustible floor protection is required to cover the area beneath the heater, and extend at least 18" (41cm) [18" (48cm) CAN] to the front and 8" (21cm) beyond each side of the fuel loading and ash removal openings [side of stove in CAN], the floor protection must extend under the flue onnector and extend 2" beyond each side of pipe.

VENT REQUIREMENTS: 8" diameter, single wall, minimum 24 M&G blue steel onnector with listed factory-built Type HT ohimney or masonry ohimney.

OPTIONAL COMPONENTS:
Outside Air Kit Part # 83-53600
Blower Kit Part # 83-57800
CO HEAT SHIELD Part # 83-58800
SPARK SCREEN Part # 83-68800
SIDE LOCK KIT Part # 83-70807

*Refer to the Installation Manual for additional clearance information, installation instructions, and operating instructions.

U.S. ENVIRONMENTAL PROTECTION AGENCY
Particulate Emissions: 0.65 g/hr. Tested to: EPA Method 28R
Certified to comply with 2020 crib wood particulate emission standards.

Date of Manufacture



DO NOT REMOVE OR COVER THIS LABEL

MADE IN USA

3300-212



LIMITED WARRANTY

These warranties give you specific legal rights. You may also have other rights, which vary from State to State.

Hearthstone Quality Home Heating Products, Inc. (Hearthstone) warrants to the original retail purchaser only (the "Original Purchaser") the new appliance manufactured by Hearthstone, purchased by the Original Purchaser and installed by an authorized Hearthstone dealer or their designated representative against any of the occurrences listed in this document that result from defects in material or workmanship. This warranty is not transferrable. All obligations of Hearthstone under this document commence on the date of the Original Invoice (the "Purchase Date"). The term "Limited Lifetime" is defined as 10 years from the beginning of warranty coverage. Hearthstone appliances are designed to be operated only with the fuels listed in your owner's manual.

Catalytic combustor LIMITED LIFETIME WARRANTY: The catalytic combustors are covered directly by the combustor manufacturer, Applied Ceramics. Included with your stove you will find the LIMITED LIFETIME WARRANTY for the catalysts, as well as a warranty card.

Catalyst Model Number: ACI-6M2 Catalyst Manufacturer: APPLIED CERAMICS

APPLIED CERAMICS warrants to the consumer who purchases a FIRECAT STEEL COMBUSTOR as a component in an EPA certified solid fuel appliance, to replace at no charge to the consumer the FIRECAT STEEL COMBUSTOR that ceases to function with two (2) years from the date of purchase by the original consumer, provided that the following conditions are met:

- (1) A copy of the original bill of sale that includes place and date of purchase must be submitted with the warranty claim.
- (2) The original FIRECAT STEEL COMBUSTOR must be returned to APPLIED CERAMICS
- (3) The FIRECAT STEEL COMBUSTOR must not have been mechanically abused, nor must the wrong fuels have been used in the appliance.

If after two years the FIRECAT STEEL COMBUSTOR fails to function, the prorated warranty will allow replacement at the following special price schedule:

Year 3	\$130.00
Year 4	\$140.00
Year 5	\$150.00
Year 6	\$160.00
Year 7 and after	at current retail price

Conditions 1, 2, and 3 also apply to the Prorated portion of the warranty. Any EPA certified solid fuel appliance will receive one replacement catalyst for each defective catalyst returned during the three year period. The consumer will be responsible for any removal, any servicing, and return of any items required for filing the warranty claim. This warranty is APPLIED CERAMIC'S exclusive warranty, and APPLIED CERAMICS, disclaims any other express or implied warranty for the FIRECAT STEEL COMBUSTOR, including any warranty or merchantability fitness for a particular use.

Ensure the catalyst is well wrapped and padded for shipment in bubble wrap, or similar material. Ship the catalyst with padding inside of a cardboard box.

All warranty claims must include \$12.50 for postage and handling within the continental U.S. Alaska and Canada claims must include \$35.00.

Please allow 2-3 weeks for delivery. Order online @ www.firecatcombustors.com

Please read and understand the full warranty. Please return the completed warranty card promptly to Applied Ceramics. The warranty card, and any warranty claims can be shipped to:

Applied Ceramics
5555 Pleasantdale Road
Doraville, GA, 30340

Stove components Limited Warranty

Warranty Period	Wood	Gas	Pellet	Covered Components
Limited Lifetime	X	X	X	Stone
	X	X	X	Cast iron not listed elsewhere
	X			Clean burning air supply system*
5 Year	X	X	X	Door handles and latches
	X	X	X	Steel Components and Firebox
		X		Burner and logs
3 Year			X	Burn Pot and Baffles
2 Year	X	X	X	Appliance Electrical and Gas Components
	X	X		Refractory, Vermiculite Panels, Baffles
1 Year	X	X	X	Enamel finish against peeling or fading
	X	X	X	Accessories
	X	X	X	Glass
	X			Ash Grate
	X	X	X	All components not listed elsewhere

Any parts repaired or replaced during the limited warranty period will be warranted under the terms of the limited warranty for a period not to exceed the remaining term of the original limited warranty or one year, whichever is longer.

Parts: Hearthstone will replace through an authorized dealer, defective parts covered by the foregoing warranty at no charge.

Labor: Within the first (1st) year after the Purchase Date, Hearthstone will pay for warranty labor performed by an authorized Dealer at Hearthstone’s published labor rates in effect at the time the labor is performed only if the appliance is installed by an authorized dealer or their designated representative. Otherwise or thereafter, the Original Purchaser is responsible for the cost of labor.

Shipping cost for parts: Within the first ninety (90) days after the Purchase Date, Hearthstone will pay for the shipping of appliance parts covered by any of the foregoing warranties to and from Hearthstone or an authorized Dealer, as the case may be. Thereafter, the Original Purchaser is responsible for all shipping costs related to shipping appliance parts to and from Hearthstone or an authorized Dealer, as the case may be.

Shipping cost for the appliance: Within the first (1st) year after the Purchase Date, if the Original Purchaser is instructed to return the appliance to Hearthstone or an authorized Dealer for repair, Hearthstone will pay fifty percent (50%) and the Original Purchaser will pay fifty percent (50%) of the shipping costs related to shipping the appliance to and from Hearthstone or an authorized Dealer, as the case may be. Thereafter, the Original Purchaser is responsible for one hundred percent (100%) of all of the shipping costs related to shipping the appliance to and from Hearthstone or an authorized Dealer, as the case may be. Notwithstanding any other provision of this document, in no event will Hearthstone pay for any Dealer fees or other fees for pick up or delivery of the appliance returned for repair; the Original Purchaser shall be responsible for any such fees.

EXCLUSIONS & CONDITIONS

The warranties contained in this document do not cover, nor is Hearthstone responsible for:

1. Damages resulting from:
 - a. Failure to install, operate, or maintain the appliance in accordance with the owner's manual, operating instructions, installation instructions, or safety rating label provided with the appliance.
 - b. Over-firing the appliance. Over-firing can be identified by, but not limited to, warped cast iron or steel, rust colored cast iron, bubbling, cracking and discoloration of steel or enamel finishes.
 - c. Failure to install the appliance in accordance with all national or local building codes.
 - d. Shipping or improper handling.
 - e. Improper operation, abuse, misuse, continued operation with damaged, corroded, or failed components, accident, or improper/incorrect service or repairs.
 - f. Environmental conditions, inadequate ventilation, negative pressure, or improper drafting caused by tightly sealed constructions, insufficient make-up air supply, or air handling devices such as exhaust fans, forced air furnaces, or other such causes.
 - g. Damage caused by direct exposure to water.
 - h. Use of fuels other than those specified in the owner's manual.
 - i. Installation or use of components not supplied with the appliance, or any other components not expressly authorized and approved by Hearthstone.
 - J. Modifications of the appliance not expressly authorized and approved by Hearthstone in writing
 - K. Interruptions or fluctuations of electrical power supplied to the appliance.
2. All stones are warranted against cracking or breakage due to thermal stress, excluding surface and hairline cracks and scratches that do not affect the operation, or safety of the appliance.
3. Repair or replacement of wear parts. Such parts that are subject to normal wear and tear during the warranty period such as paint, gaskets, baffles, refractory materials, ash grates, and glass.
4. Damage resulting from installation, modification, alteration, repair or service of the appliance by any party other than an authorized Hearthstone dealer (a "Dealer") or their designated representative, or Hearthstone.
5. Damage due to water or condensation due to installation of the appliance in a high moisture area.
6. Damage due to installation of the appliance in an atmosphere contaminated by damaging chemicals, including but not limited to chlorine, fluorine or salts.
7. Scratches on glass, enameled surfaces or stones due to mechanical abrasion.
8. Noise caused by expansion or contraction caused by the heating and cooling of the appliance.
9. Odors caused by the heating of the appliance, or surrounding materials
10. Consequential damage caused by leaking of condensate during startup
11. A defect in any part of the appliance if the Original Purchaser fails to comply with Hearthstone's or a Dealer's request to ship the part or the appliance to Hearthstone or a Dealer, as the case may be.
12. Replacement stones and enameled parts are taken from current stock, and may not match originals in color, grain, or pattern. Hearthstone will supply replacement parts for discontinued parts in finishes or colors as available, or at their discretion.
13. Hearthstone's obligation under this warranty does not extend to the appliance's ability to heat the desired space. Information is provided to assist the customer and the dealer in selecting the appropriate appliance for the application. Consideration must be given to appliance location and configuration, environmental conditions, insulation and air tightness of the structure.

THE WARRANTIES CONTAINED IN THIS DOCUMENT ARE EXCLUSIVE AND ARE GIVEN BY HEARTHSTONE AND ACCEPTED BY THE ORIGINAL PURCHASER IN LIEU OF ALL OTHER EXPRESS WARRANTIES AND ANY OBLIGATIONS, LIABILITIES, RIGHTS, CLAIMS, OR REMEDIES IN CONTRACT OR TORT, WHETHER OR NOT ARISING FROM HEARTHSTONE'S NEGLIGENCE, ACTUAL OR IMPUTED. ALL IMPLIED WARRANTIES, INCLUDING THE WARRANTIES OF MERCHANTABILITY AND FITNESS FOR A PARTICULAR PURPOSE, ARE GIVEN ONLY TO THE EXTENT REQUIRED BY FEDERAL OR STATE LAW. EXCEPT AS OTHERWISE REQUIRED BY STATE LAW, UPON THE EXPIRATION OF THE EXPRESS LIMITED WARRANTIES CONTAINED HEREIN, NO IMPLIED WARRANTIES, INCLUDING THE IMPLIED WARRANTIES OF MERCHANTABILITY OR FITNESS FOR A PARTICULAR PURPOSE, SHALL APPLY TO THE SUBJECT APPLIANCE. SOME STATES DO NOT ALLOW LIMITATIONS ON HOW LONG AN IMPLIED WARRANTY LASTS, SO THE ABOVE LIMITATION MAY NOT APPLY TO YOU.

THE WARRANTIES CONTAINED IN THIS DOCUMENT EXTEND ONLY TO THE ORIGINAL PURCHASER OF THE APPLIANCE WARRANTED HEREUNDER. THEY ARE NOT TRANSFERRABLE AND DO NOT EXTEND TO ANY SUBSEQUENT OWNERS.

UNDER NO CIRCUMSTANCES SHALL HEARTHSTONE BE LIABLE TO THE ORIGINAL PURCHASER OR ANY OTHER PERSON FOR ANY INCIDENTAL OR CONSEQUENTIAL DAMAGES, INCLUDING BUT NOT LIMITED TO DAMAGE TO PROPERTY OR PERSONAL INJURIES, WHETHER ARISING OUT OF LOSS OF USE, BREACH OF WARRANTY, TORT, OR OTHERWISE, EVEN IF HEARTHSTONE HAS BEEN APPRAISED OF THE POSSIBILITY OF SUCH DAMAGES. SOME STATES DO NOT ALLOW THE EXCLUSION OR LIMITATION OF INCIDENTAL OR CONSEQUENTIAL DAMAGES, SO THE ABOVE LIMITATION OR EXCLUSION MAY NOT APPLY TO YOU.

QUALIFYING FOR WARRANTY COVERAGE

To obtain performance of any obligation under this document, the Original Purchaser must, within the applicable warranty time period, contact their original Hearthstone dealer, or the current responsible local Hearthstone dealer, for instructions regarding the return of defective parts for repair, the return of the appliance for repair, or to schedule a Dealer service call. The Original Purchaser should refer to the Dealer Network search engine contained on Hearthstone's Web site (www.hearthstonestoves.com) if the original dealer is not available, to find a Hearthstone dealer nearest to the Original Purchaser's location.

REMEDY

The remedy for any breach of the foregoing warranties will consist of repair or replacement, at Hearthstone's option, of any covered defect in the appliance. When the Original Purchaser contacts a Hearthstone Dealer, the Dealer on behalf of Hearthstone, as the case may be, will instruct the Original Purchaser to either return the defective part, or the entire appliance (if requested), to the Dealer or Hearthstone or allow a Dealer to make a service call at the place where the appliance is located. Hearthstone may require that a digital picture be provided to support the claim. Notwithstanding any other provision of this document, the Original Purchaser shall pay for any fees and service charges related to a Dealer's service call or the shipping charges associated with the return.

WARRANTY REGISTRATION

The Original Purchaser can complete their warranty registration on our website at www.hearthstonestoves.com, or send a completed and signed Warranty Registration Form, which is enclosed in the appliance document packet, to the following address:

Hearthstone Quality Home Heating Products, Inc.
Warranty Department
317 Stafford Avenue
Morrisville, VT 05661

NOTE: SENDING IN THE SIGNED WARRANTY REGISTRATION FORM IS *NOT REQUIRED* AS A CONDITION OF WARRANTY COVERAGE OR HEARTHSTONE'S PERFORMANCE.

APPENDIX 8: Photographs of test set up

Dilution picture Dia 8

Picture 1: Sampling system

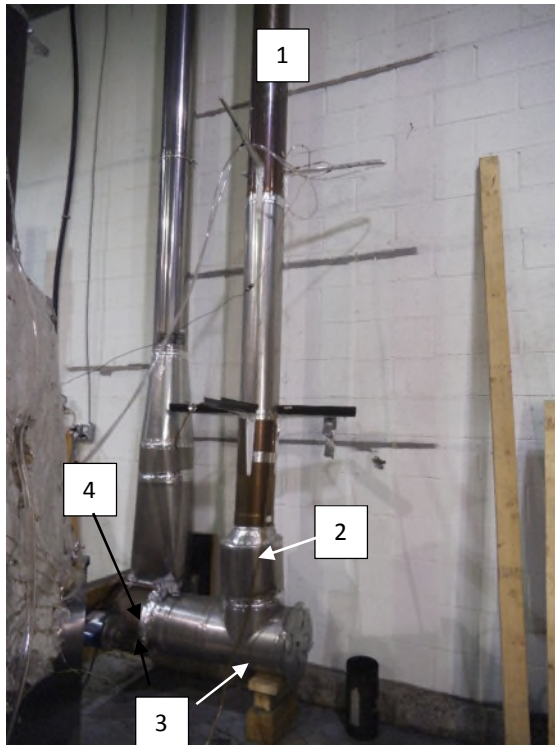

- 1 : 8 in dia Stainless steel pipe
- 2 : 16 in. Between sampling probe and lower elbow
- 3 : Air intake with damper to adjust flow rate
- 4 : Exhaust blower

Picture 2: Hood and mixing baffle

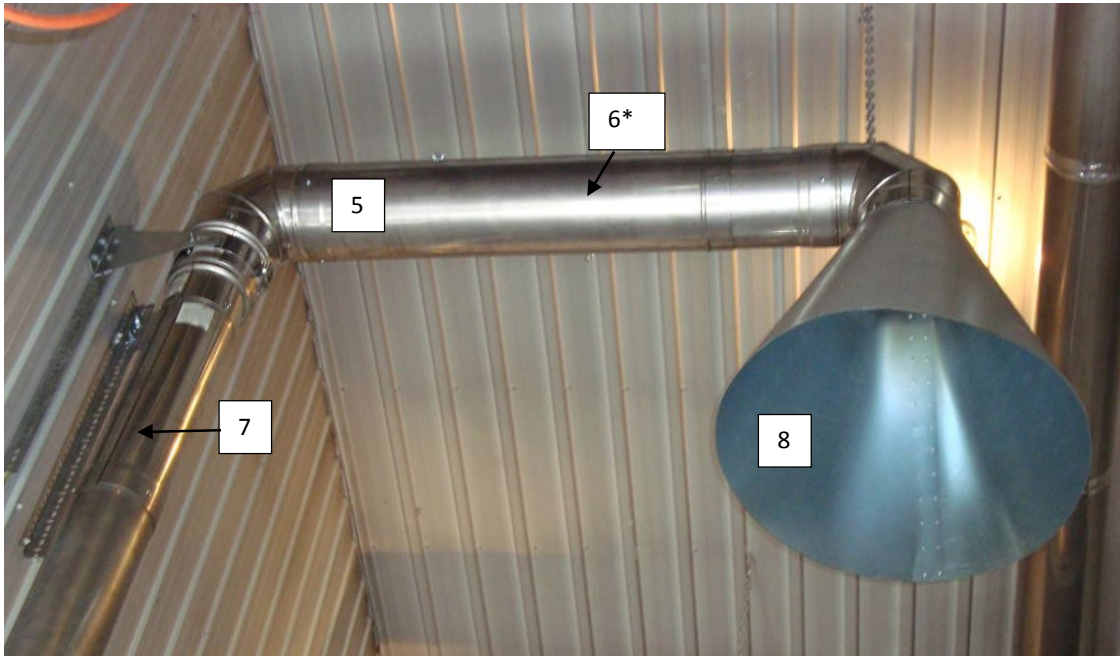

*The arrow point the deflectors inside of the pipe

- 5 : 8 in. dia. Stainless steel pipe
- 6 : Mixing baffle (2) location 1 foot between baffles
- 7 : 10 feet long between velocity port and upper elbow
- 8 : 48 in. dia. Galvanized steel smoke captures hood

Picture 3: Stack sampling



Picture 3.1: Gas analysis and temperature probe

Picture 3.2: chimney support

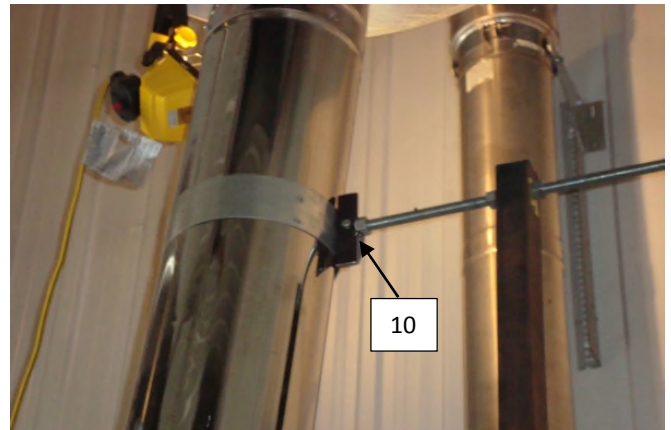
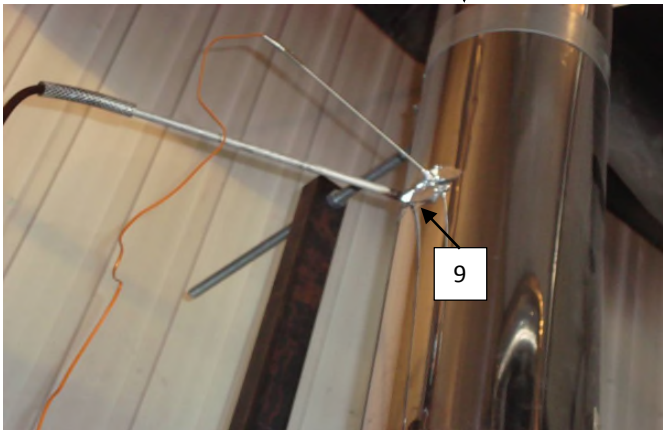

9 : Temperature and gas analyser sampling ports located 9 feet above platform

10 : Exhaust system support bracket

Picture 4: Tunnel flow measurement and sampling probe

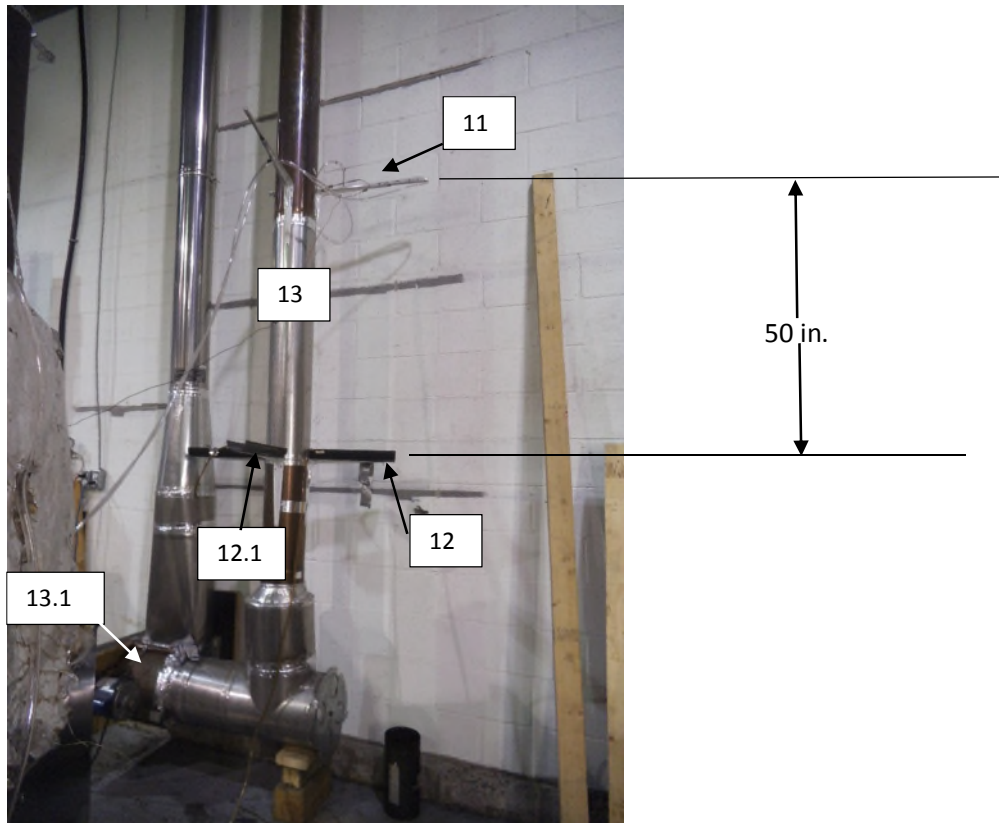

11 : Velocity port

12 : Sampling port, 2 sampling probes with 2x48 mm. dia.filter each. Filter used:
Millipore AP4004700

12.1 : Sampling port, sampling probes with 2x48 mm. dia.filter each. Filter used:
Millipore AP4004700, for first hour sampling

13 : 18 feet long dilution tunnel

13.1 : Extraction blower

Picture 5: Draft sampling



14 : Draft sampling port located 6 in. from the flue outlet

Picture 6: Equipments

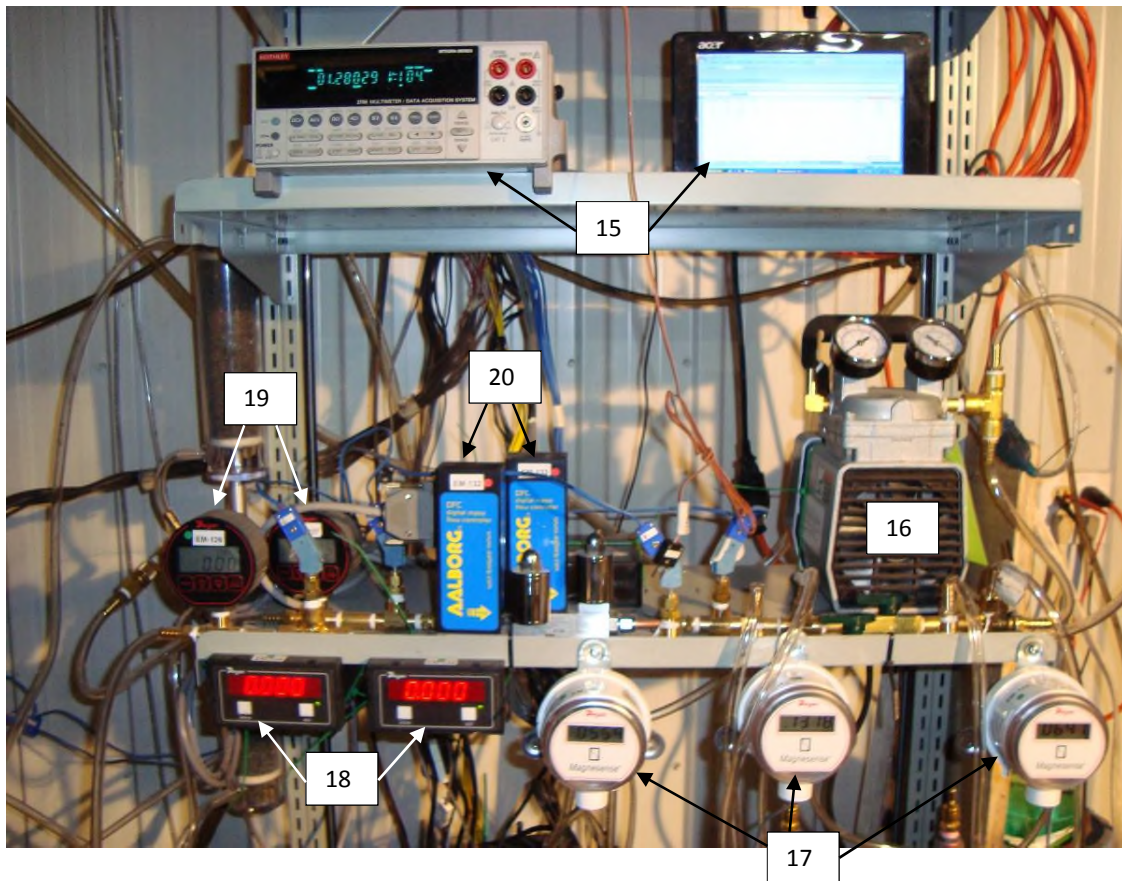

- 15 : Acquisition system
- 16 : Vacuum pump
- 17 : Digital manometer
- 18 : Digital read out for mass flow meter
- 19 : Digital vacuum gage
- 20 : Mass flow meter

Picture 7: Gaz analyser



Picture 8: Reference dry gas meter

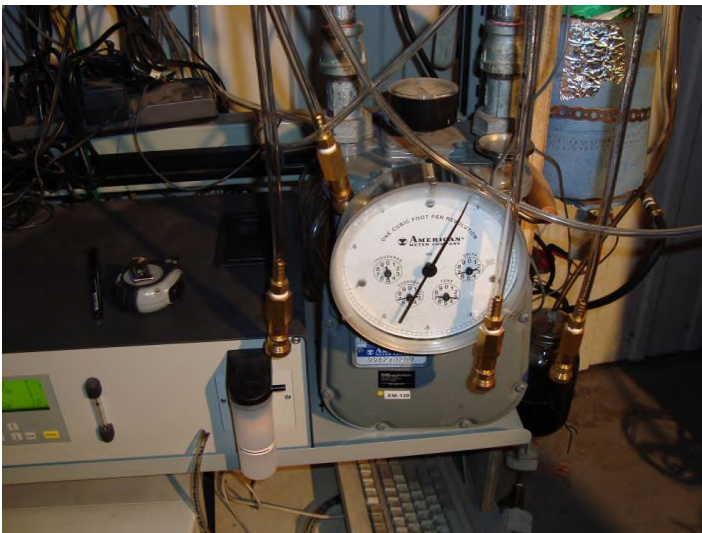

Picture 9: Heat exchanger

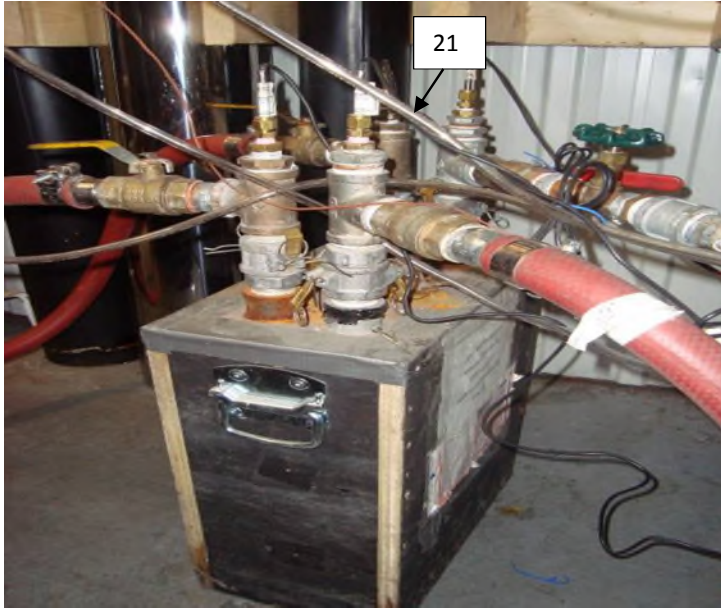

21 : PT 100 insertion probe

Picture 10: Water flow meter

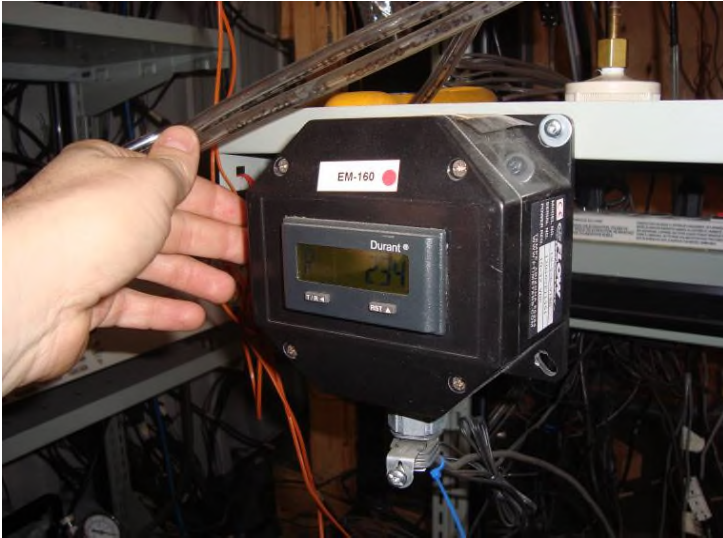

Picture 11: Dry gas meter



Picture 12 : Dilution tunnel sample system

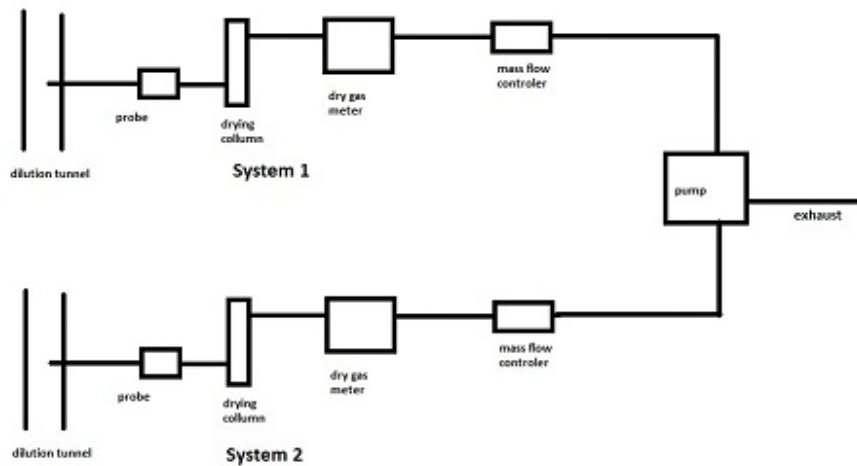

Picture 13: Dilution tunnel

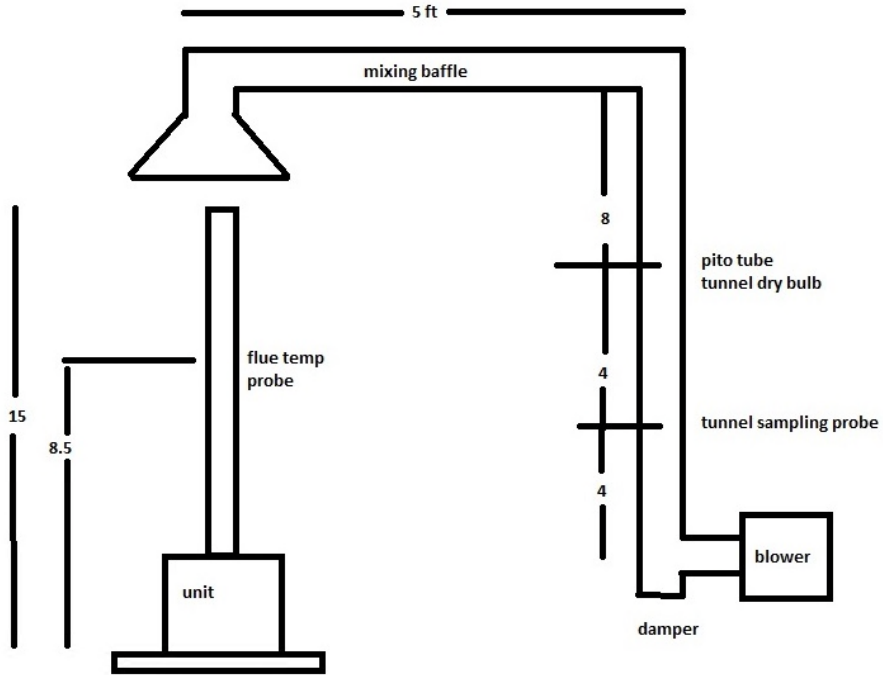

APPENDIX 9: Test load photographs

Run 2



Run 3



Run 4



Run 5



APPENDIX 13: Operating instruction



MODEL: 8362
 DATE: 7/19/2018
 TEST ENGINEER: WE

WOOD STOVE OPERATING INSTRUCTIONS

BURN RATE CATEGORY	KINDLING	FIRST WARM UP	SECOND WARM UP AND PREBURN	PREBURN START	AIR SETTINGS	TEST FAN SETTING	COAL BED PREP	TEST LOAD	START OF TEST
LOW .9KGH	3 LBS, BURN TO ABOUT 1.25 LBS CRACK DOOR AS NEEDED	SEE FIGURE 1 FOR SIZES AND WEIGHT RANGE KEEP DOOR CRACKED UNTIL ALL WOOD IS FULLY INVOLVED, BURN TO 3 LBS	SEE FIGURE 1 FOR SIZES AND WEIGHT RANGE, BURN TO "UP" COAL BED RANGE	.4LBS ABOVE COAL BED RANGE (UP RANGE), CLOSE BYPASS, SET PRIMARY AIR TO TEST SETTING	WARMUP SET AIR TO FULL OPEN, AT PREBURN START SET AIR TO 1/16"	FAN OFF FOR WARMUP, FAN ON LOW FOR PREBURN AND TEST	BREAK UP COALS ABOUT 2 TO 3 INCHES, MAKE EVEN DENSITY AND HIGHT, FRONT TO BACK AND SIDE TO SIDE 2 MIN BEFORE START OF TEST	SEE FIGURE 2 FOR SIZE AND NUMBER OF PIECES 16.5 LBS IDEAL	AT 1 HR, OPEN BYPASS AND PRIMARY, INSERT WOOD PRESSING SPACERS INTO COAL BED, CLOSE LOAD DOOR AND BYPASS, @ 5 MIN SET PRIMARY TO 1/16", KEEP LPAO CLEAR OF COALS IN FRONT OF TEST LOAD
MED LOW .9KGH	3 LBS, BURN TO ABOUT 1.25 LBS CRACK DOOR AS NEEDED	SEE FIGURE 1 FOR SIZES AND WEIGHT RANGE KEEP DOOR CRACKED UNTIL ALL WOOD IS FULLY INVOLVED, BURN TO 3 LBS	SEE FIGURE 1 FOR SIZES AND WEIGHT RANGE, BURN TO "UP" COAL BED RANGE	.4LBS ABOVE COAL BED RANGE (UP RANGE), CLOSE BYPASS, SET PRIMARY AIR TO TEST SETTING	WARMUP SET AIR TO FULL OPEN, AT PREBURN START SET AIR TO 1/16"	FAN OFF FOR WARMUP, FAN ON LOW FOR PREBURN AND TEST	BREAK UP COALS ABOUT 2 TO 3 INCHES, TO MAX HEIGHT OF DOOR SILL, MAKE EVEN DENSITY AND HIGHT, FRONT TO BACK AND SIDE TO SIDE 2 MIN BEFORE START OF TEST	SEE FIGURE 2 FOR SIZE AND NUMBER OF PIECES 16.5 LBS IDEAL	AT 1 HR, OPEN BYPASS AND PRIMARY, INSERT WOOD PRESSING SPACERS INTO COAL BED, CLOSE LOAD DOOR AND BYPASS AND @ 5 MIN SET PRIMARY TO 1/16", KEEP LPAO CLEAR OF COALS IN FRONT OF TEST LOAD
MED HIGH 1.4KGH	3 LBS, BURN TO ABOUT 1.25 LBS CRACK DOOR AS NEEDED	SEE FIGURE 1 FOR SIZES AND WEIGHT RANGE KEEP DOOR CRACKED UNTIL ALL WOOD IS FULLY INVOLVED, BURN TO 3 LBS	SEE FIGURE 1 FOR SIZES AND WEIGHT RANGE, BURN TO "UP" COAL BED RANGE	1.4LBS ABOVE COAL BED RANGE (UP RANGE), CLOSE BYPASS, SET PRIMARY AIR TO TEST SETTING	WARMUP SET AIR TO FULL OPEN, AT PREBURN START SET AIR TO 3/4"	FAN OFF FOR WARMUP, FAN ON LOW FOR PREBURN AND TEST	BREAK UP COALS ABOUT 2 TO 3 INCHES, TO MAX HEIGHT OF DOOR SILL, MAKE EVEN DENSITY AND HIGHT, FRONT TO BACK AND SIDE TO SIDE 2 MIN BEFORE START OF TEST	SEE FIGURE 2 FOR SIZE AND NUMBER OF PIECES 16.5 LBS IDEAL	OPEN BYPASS AND PRIMARY, INSERT WOOD PRESSING SPACERS INTO COAL BED, CLOSE LOAD DOOR. CLOSE BYPASS @ 5 MIN SET PRIMARY TO 1/4", KEEP LPAO CLEAR OF COALS IN FRONT OF TEST LOAD
HIGH 2KGH	3 LBS, BURN TO ABOUT 1.25 LBS CRACK DOOR AS NEEDED	SEE FIGURE 1 FOR SIZES AND WEIGHT RANGE KEEP DOOR CRACKED UNTIL ALL WOOD IS FULLY INVOLVED, BURN TO 3 LBS	SEE FIGURE 1 FOR SIZES AND WEIGHT RANGE, BURN TO "UP" COAL BED RANGE	START WHEN SECOND WARMUP LOAD IS ADDED,CLOSE BYPASS, SET PRIMARY AIR TO TEST SETTING	WARMUP SET AIR TO FULL OPEN, AT PREBURN START SET AIR TO FULL OPEN"	FAN OFF FOR WARMUP, FAN ON HIGH FOR PREBURN AND TEST	BREAK UP COALS ABOUT 2 TO 3 INCHES, TO MAX HEIGHT OF DOOR SILL, MAKE EVEN DENSITY AND HIGHT, FRONT TO BACK AND SIDE TO SIDE 2 MIN BEFORE START OF TEST	SEE FIGURE 2 FOR SIZE AND NUMBER OF PIECES 16.5 LBS IDEAL	OPEN BYPASS AND PRIMARY, INSERT WOOD PRESSING SPACERS INTO COAL BED, CLOSE LOAD DOOR. CLOSE BYPASS AND SET PRIMARY TO FULL OPEN, KEEP LPAO CLEAR OF COALS IN FRONT OF TEST LOAD

FIGURE 1 Warmup Load Arrangement

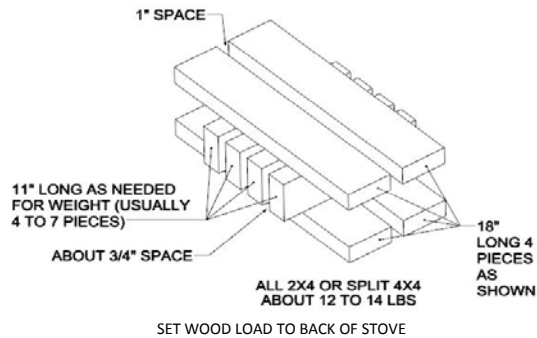

FIGURE 2 Test Load Arrangement

